



STANDARD OPERATING PROCEDURES

SOP: 2009
PAGE: 1 of 33
REV: 0.0
DATE: 11/16/94

DRUM SAMPLING

CONTENTS

- 1.0 SCOPE AND APPLICATION
- 2.0 METHOD SUMMARY
- 3.0 SAMPLE PRESERVATION, CONTAINERS, HANDLING, AND STORAGE
- 4.0 INTERFERENCES AND POTENTIAL PROBLEMS
- 5.0 EQUIPMENT/APPARATUS
- 6.0 REAGENTS
- 7.0 PROCEDURES
 - 7.1 Preparation
 - 7.2 Drum Excavation
 - 7.3 Drum Inspection
 - 7.4 Drum Staging
 - 7.5 Drum Opening
 - 7.5.1 Manual Drum Opening with a Bung Wrench
 - 7.5.2 Manual Drum Opening with a Drum Deheader
 - 7.5.3 Manual Drum Opening with a Hand Pick, Pickaxe, or Spike
 - 7.5.4 Remote Drum Opening with a Backhoe Spike
 - 7.5.5 Remote Drum Opening with Hydraulic Devices
 - 7.5.6 Remote Drum Opening with Pneumatic Devices
 - 7.6 Drum Sampling
 - 7.6.1 Glass Thief Sampler
 - 7.6.2 COLIWASA Sampler
 - 7.6.3 Coring Device
 - 7.7 Hazard Categorization
- 8.0 CALCULATIONS
- 9.0 QUALITY ASSURANCE/QUALITY CONTROL
- 10.0 DATA VALIDATION
- 11.0 HEALTH AND SAFETY



STANDARD OPERATING PROCEDURES

SOP: 2009
PAGE: 2 of 33
REV: 0.0
DATE: 11/16/94

DRUM SAMPLING

CONTENTS (cont)

12.0 REFERENCES

13.0 APPENDICES

A - Attachments

B - Figures

SUPERSEDES: SOP #2009; Revision 1.0; 03/12/92; U.S. EPA Contract EP-W-09-031.



STANDARD OPERATING PROCEDURES

SOP: 2009
PAGE: 3 of 33
REV: 0.0
DATE: 11/16/94

DRUM SAMPLING

1.0 SCOPE AND APPLICATION

The purpose of this standard operating procedure (SOP) is to provide technical guidance on implementing safe and cost-effective response actions at hazardous waste sites containing drums with unknown contents. Container contents are sampled and characterized for disposal, bulking, recycling, segregation, and classification purposes.

These are standard (i.e., typically applicable) operating procedures which may be varied or changed as required, dependent on site conditions, equipment limitations or limitations imposed by the procedure. In all instances, the ultimate procedures employed should be documented and associated with the final report.

Mention of trade names or commercial products does not constitute U.S. Environmental Protection Agency (U.S. EPA) endorsement or recommendation for use.

2.0 METHOD SUMMARY

Prior to sampling, drums must be excavated, (if necessary), inspected, staged, and opened. Drum excavation must be performed by qualified personnel. Inspection involves the observation and recording of visual qualities of each drum and any characteristics pertinent to the classification of the drum's contents. Staging involves the physical grouping of drums according to classifications established during the physical inspection. Opening of closed drums can be performed manually or remotely. Remote drum opening is recommended for worker safety. The most widely used method of sampling a drum involves the use of a glass thief. This method is quick, simple, relatively inexpensive, and requires no decontamination. The contents of a drum can be further characterized by performing various field tests.

3.0 SAMPLE PRESERVATION, CONTAINERS, HANDLING, AND STORAGE

Samples collected from drums are considered waste samples and as such, adding preservatives is not required due to the potential reaction of the sample with the preservative. Samples should, however, be cooled to 4°C and protected from sunlight in order to minimize any potential reaction due to the light sensitivity of the sample.

Sample bottles for collection of waste liquids, sludges, or solids are typically wide mouth amber jars with Teflon-lined screw caps. Actual volume required for analysis should be determined in conjunction with the laboratory performing the analysis.

Waste sample handling procedures should be as follows:

1. Label the sample container with the appropriate sample label and complete the appropriate field data sheet(s). Place sample container into two resealable plastic bags.
2. Place each bagged sample container into a shipping container which has been lined with plastic. Pack the container with enough non-combustible, absorbent, cushioning material to minimize the possibility of



STANDARD OPERATING PROCEDURES

SOP: 2009
PAGE: 4 of 33
REV: 0.0
DATE: 11/16/94

DRUM SAMPLING

containers breaking, and to absorb any material which may leak.

Note: Depending on the nature and quantity of the material to be shipped, different packaging may be required. The transportation company or a shipping/receiving expert should be consulted prior to packing the samples.

3. Complete a chain of custody record for each shipping container, place into a resealable plastic bag, and affix to the inside lid of the shipping container.
4. Secure and custody seal the lid of the shipping container. Label the shipping container appropriately and arrange for the appropriate transportation mode consistent with the type of hazardous waste involved.

4.0 INTERFERENCES AND POTENTIAL PROBLEMS

If buried drums are suspected, geophysical investigation techniques such as magnetometry or ground penetrating radar may be employed in an attempt to determine the location and depth of drums. During excavation, the soil must be removed with great caution to minimize the potential for drum rupture.

Until the contents are characterized, sampling personnel should assume that unlabelled drums contain hazardous materials. Labeled drums are frequently mislabeled, especially drums that are reused. Because a drum's label may not accurately describe its contents, extreme caution must be exercised when working with or around drums.

If a drum which contains a liquid cannot be moved without rupture, its contents may be immediately transferred to a sound drum using an appropriate method of transfer based on the type of waste. In any case, preparations should be made to contain the spill (i.e., spill pads, dike, etc.) should one occur.

If a drum is leaking, open, or deteriorated, then it must be placed immediately in overpack containers.

The practice of tapping drums to determine their contents is neither safe nor effective and should not be used if the drums are visually overpressurized or if shock-sensitive materials are suspected. A laser thermometer may be effective in order to determine the level of the drum contents via surface temperature differences.

Drums that have been overpressurized to the extent that the head is swollen several inches above the level of the chime should not be moved. A number of devices have been developed for venting critically swollen drums. One method that has proven to be effective is a tube and spear device. A light aluminum tube (3 meters long) is positioned at the vapor space of the drum. A rigid, hooking device attached to the tube, goes over the chime and holds the tube securely in place. The spear is inserted in the tube and positioned against the drum wall. A sharp blow on the end of the spear drives the sharpened tip through the drum and the gas vents along the grooves. Venting should be done from behind a wall or barricade. Once the pressure has been relieved, the bung can be removed and the drum sampled.

Because there is potential for accidents to occur during handling, particularly initial handling, drums should only be handled if necessary. All personnel should be warned of the hazards prior to handling drums. Overpack drums and an adequate volume of absorbent material should be kept near areas where minor spills may occur. Where major spills may occur, a containment berm adequate to contain the entire volume of liquid in the drums should be constructed before any handling takes place. If drum contents spill,



STANDARD OPERATING PROCEDURES

SOP: 2009
PAGE: 5 of 33
REV: 0.0
DATE: 11/16/94

DRUM SAMPLING

personnel trained in spill response should be used to isolate and contain the spill.

5.0 EQUIPMENT/APPARATUS

The following are standard materials and equipment required for sampling:

- Personal protection equipment
- Wide-mouth amber glass jars with Teflon® cap liner, approximately 500 mL volume
- Other appropriate sample jars
- Uniquely numbered sample identification labels with corresponding data sheets
- Drum/Tank Sampling Data Sheets and Field Test Data Sheets for Drum/Tank Sampling
- Chain of Custody records
- Decontamination materials
- Glass thieving tubes or COLIWASA
- Coring device
- Stainless steel spatula or spoons
- Laser thermometer
- Drum overpacks
- Absorbent material for spills
- Drum opening devices

Bung Wrench

A common method for opening drums manually is using a universal bung wrench. These wrenches have fittings made to remove nearly all commonly encountered bungs. They are usually constructed of a non-sparking metal alloy (i.e., brass, bronze/manganese, aluminum, etc.) formulated to reduce the likelihood of sparks. The use of a "NON-SPARKING" wrench does not completely eliminate the possibility of a spark being produced.

Drum Deheader

One means by which a drum can be opened manually when a bung is not removable with a bung wrench is by using a drum deheader. This tool is constructed of forged steel with an alloy steel blade and is designed to cut the lid of a drum off or part way off by means of a scissors-like cutting action. A limitation of this device is that it can be attached only to closed head drums. Drums with removable heads must be opened by other means.

Hand Pick, Pickaxe, and Hand Spike

These tools are usually constructed of brass or a non-sparking alloy with a sharpened point that can penetrate the drum lid or head when the tool is swung. The hand picks or pickaxes that are most commonly used are commercially available; whereas, the spikes are generally uniquely fabricated four foot long poles with a pointed end.

Backhoe Spike

Another means used to open drums remotely for sampling is a metal spike attached or welded to a backhoe bucket. This method is very efficient and is often used in large-scale operations.



STANDARD OPERATING PROCEDURES

SOP: 2009
PAGE: 6 of 33
REV: 0.0
DATE: 11/16/94

DRUM SAMPLING

Hydraulic Drum Opener

Recently, remotely operated hydraulic devices have been fabricated to open drums. This device uses hydraulic pressure to force a non-sparking spike through the wall of a drum. It consists of a manually operated pump which pressurizes fluid through a length of hydraulic line.

Pneumatic Devices

A pneumatic bung remover consists of a compressed air supply that is controlled by a two-stage regulator. A high pressure air line of desired length delivers compressed air to a pneumatic drill, which is adapted to turn bung fitting selected to fit the bung to be removed. An adjustable bracketing system has been designed to position and align the pneumatic drill over the bung. This bracketing system must be attached to the drum before the drill can be operated. Once the bung has been loosened, the bracketing system must be removed before the drum can be sampled. This remote bung opener does not permit the slow venting of the container, and therefore appropriate precautions must be taken. It also requires the container to be upright and relatively level. Bungs that are rusted shut cannot be removed with this device.

6.0 REAGENTS

Reagents are not typically required for preserving drum samples. However, reagents will be utilized for decontamination of sampling equipment. Decontamination solutions are specified in ERT/REAC SOP #2006, Sampling Equipment Decontamination.

7.0 PROCEDURES

7.1 Preparation

1. Determine the extent of the sampling effort, the sampling methods to be employed, and the types and amounts of equipment and supplies needed.
2. Obtain necessary sampling and monitoring equipment.
3. Decontaminate or preclean equipment, and ensure that it is in working order.
4. Prepare scheduling and coordinate with staff, clients, and regulatory agency, if appropriate.
5. Perform a general site survey prior to site entry in accordance with the site specific Health and Safety Plan.
6. Use stakes, flagging, or buoys to identify and mark all sampling locations. If required the proposed locations may be adjusted based on site access, property boundaries, and surface obstructions.



STANDARD OPERATING PROCEDURES

SOP: 2009
PAGE: 7 of 33
REV: 0.0
DATE: 11/16/94

DRUM SAMPLING

7.2 Drum Excavation

If it is presumed that buried drums are on-site and prior to beginning excavation activities, geophysical investigation techniques should be utilized to approximate the location and depth of the drums. In addition, it is important to ensure that all locations where excavation will occur are clear of utility lines, pipes and poles (subsurface as well as above surface).

Excavating, removing, and handling drums are generally accomplished with conventional heavy construction equipment. These activities should be performed by an equipment operator who has experience in drum excavation. During excavation activities, drums must be approached in a manner that will avoid digging directly into them.

The soil around the drum should be excavated with non-sparking hand tools or other appropriate means and as the drums are exposed, a visual inspection should be made to determine the condition of the drums. Ambient air monitoring should be done to determine the presence of unsafe levels of volatile organics, explosives, or radioactive materials. Based on this preliminary visual inspection, the appropriate mode of drum excavation and handling may be determined.

Drum identification and inventory should begin before excavation. Information such as location, date of removal, drum identification number, overpack status, and any other identification marks should be recorded on the Drum/Tank Sampling Data Sheet (Attachment 1, Appendix A).

7.3 Drum Inspection

Appropriate procedures for handling drums depend on the contents. Thus, prior to any handling, drums should be visually inspected to gain as much information as possible about their contents. The drums should be inspected for the following:

1. Drum condition, corrosion, rust, punctures, bungs, and leaking contents.
2. Symbols, words, or other markings on the drum indicating hazards (i.e., explosive, radioactive, toxic, flammable), or further identifying the drums.
3. Signs that the drum is under pressure.
4. Shock sensitivity.

Monitoring should be conducted around the drums using instruments such as radiation meters, organic vapor analyzers (OVA) and combustible gas indicators (CGI).

Survey results can be used to classify the drums into categories, for instance:

- Radioactive
- Leaking/deteriorating
- Bulging
- Lab packs
- Explosive/shock sensitive
- Empty



STANDARD OPERATING PROCEDURES

SOP: 2009
PAGE: 8 of 33
REV: 0.0
DATE: 11/16/94

DRUM SAMPLING

All personnel should assume that unmarked drums contain hazardous materials until their contents have been categorized. Once a drum has been visually inspected and any immediate hazard has been eliminated by overpacking or transferring the drum's contents, the drum is affixed with a numbered tag and transferred to a staging area. Color-coded tags, labels or bands should be used to identify the drum's category based on visual inspection. A description of each drum, its condition, any unusual markings, the location where it was buried or stored, and field monitoring information are recorded on a Drum/Tank Sampling Data Sheet (Attachment 1, Appendix A). This data sheet becomes the principal record keeping tool for tracking the drum on-site.

7.4 Drum Staging

Prior to sampling, the drums should be staged to allow easy access. Ideally, the staging area should be located just far enough from the drum opening area to prevent a chain reaction if one drum should explode or catch fire when opened.

During staging, the drums should be physically separated into the following categories: those containing liquids, those containing solids, those containing lab packs, and those which are empty. This is done because the strategy for sampling and handling drums/containers in each of these categories will be different. This may be achieved by visual inspection of the drum and its labels, codes, etc. Solids and sludges are typically disposed of in open top drums. Closed head drums with a bung opening generally contain liquid.

Where there is good reason to suspect that drums contain radioactive, explosive, or shock-sensitive materials, these drums should be staged in a separate, isolated area. Placement of explosives and shock-sensitive materials in diked and fenced areas will minimize the hazard and the adverse effects of any premature detonation of explosives.

Where space allows, the drum opening area should be physically separated from the drum removal and drum staging operations. Drums are moved from the staging area to the drum opening area one at a time using forklift trucks equipped with drum grabbers or a barrel grapppler. In a large-scale drum handling operation, drums may be conveyed to the drum opening area using a roller conveyor. Drums may be restaged as necessary after opening and sampling.

7.5 Drum Opening

There are three basic techniques available for opening drums at hazardous waste sites:

- Manual opening with non-sparking bung wrenches
- Drum deheading
- Remote drum puncturing or bung removal

The choice of drum opening techniques and accessories depends on the number of drums to be opened, their waste contents, and physical condition. Remote drum opening equipment should always be considered in order to protect worker safety. Under OSHA 1910.120, manual drum opening with bung wrenches or deheaders should be performed ONLY with structurally sound drums and waste contents that are known to be non-shock sensitive, non-reactive, non-explosive, and non-flammable.

7.5.1 Manual Drum Opening with a Bung Wrench



STANDARD OPERATING PROCEDURES

SOP: 2009
PAGE: 9 of 33
REV: 0.0
DATE: 11/16/94

DRUM SAMPLING

Manual drum opening with bung wrenches (Figure 1, Appendix B) should not be performed unless the drums are structurally sound (no evidence of bulging or deformation) and their contents are known to be non-shock sensitive, non-reactive, non-explosive or non-flammable. If opening the drum with bung wrenches is deemed safe, then certain procedures should be implemented to minimize the hazard:

- Field personnel should be fully outfitted with protective gear.
- Drums should be positioned upright with the bung up, or, for drums with bungs on the side, laid on their sides with the bung plugs up.
- The wrenching motion should be a slow, steady pull across the drum. If the length of the bung wrench handle provides inadequate leverage for unscrewing the plug, a "cheater bar" can be attached to the handle to improve leverage.

7.5.2 Manual Drum Opening with a Drum Deheader

Drums are opened with a drum deheader (Figure 2, Appendix B) by first positioning the cutting edge just inside the top chime and then tightening the adjustment screw so that the deheader is held against the side of the drum. Moving the handle of the deheader up and down while sliding the deheader along the chime will enable the entire top to be rapidly cut off if so desired. If the top chime of a drum has been damaged or badly dented it may not be possible to cut the entire top off. Since there is always the possibility that a drum may be under pressure, the initial cut should be made very slowly to allow for the gradual release of any built-up pressure. A safer technique would be to employ a remote method prior to using the deheader.

Self-propelled drum openers which are either electrically or pneumatically driven are available and can be used for quicker and more efficient deheading.

The drum deheader should be decontaminated, as necessary, after each drum is opened to avoid cross contamination and/or adverse chemical reactions from incompatible materials.

7.5.3 Manual Drum Opening with a Hand Pick, Pickaxe, or Spike

When a drum must be opened and neither a bung wrench nor a drum deheader is suitable, then it can be opened for sampling by using a hand pick, pickaxe, or spike (Figure 3, Appendix B). Often the drum lid or head must be hit with a great deal of force in order to penetrate it. Because of this, the potential for splash or spraying is greater than with other opening methods and therefore, this method of drum opening is not recommended, particularly when opening drums containing liquids. Some spikes used have been modified by the addition of a circular splash plate near the penetrating end. This plate acts as a shield and reduces the amount of splash in the direction of the person using the spike. Even with this shield, good splash gear is essential.

Since drums, some of which may be under pressure, cannot be opened slowly with these tools, spray from drums is common and appropriate safety measures must be taken. The pick or spike should be decontaminated after each drum is opened to avoid cross contamination and/or adverse chemical reaction from incompatible materials.



STANDARD OPERATING PROCEDURES

SOP: 2009
PAGE: 10 of 33
REV: 0.0
DATE: 11/16/94

DRUM SAMPLING

7.5.4 Remote Drum Opening with a Backhoe Spike

Remotely operated drum opening tools are the safest available means of drum opening. Remote drum opening is slow, but provides a high degree of safety compared to manual methods of opening.

In the opening area, drums should be placed in rows with adequate aisle space to allow ease in backhoe maneuvering. Once staged, the drums can be quickly opened by punching a hole in the drum head or lid with the spike.

The spike (Figure 4, Appendix B) should be decontaminated after each drum is opened to prevent cross contamination and/or adverse reaction from incompatible material. Even though some splash or spray may occur when this method is used, the operator of the backhoe can be protected by mounting a large shatter-resistant shield in front of the operator's cage. This combined with the normal personal protection gear should be sufficient to protect the operator. Additional respiratory protection can be afforded by providing the operator with an on-board airline system.

7.5.5 Remote Drum Opening with Hydraulic Devices

A piercing device with a non-sparking, metal point is attached to the end of a hydraulic line and is pushed into the drum by the hydraulic pressure (Figure 5, Appendix B). The piercing device can be attached so that a hole for sampling can be made in either the side or the head of the drum. Some of the metal piercers are hollow or tube-like so that they can be left in place if desired and serve as a permanent tap or sampling port. The piercer is designed to establish a tight seal after penetrating the container.

7.5.6 Remote Drum Opening with Pneumatic Devices

Pneumatically-operated devices utilizing compressed air have been designed to remove drum bungs remotely (Figure 6, Appendix B). Prior to opening the drum, a bung fitting must be selected to fit the bung to be removed. The adjustable bracketing system is then attached to the drum and the pneumatic drill is aligned over the bung. This must be done before the drill can be operated. The operator then moves away from the drum to operate the equipment. Once the bung has been loosened, the bracketing system must be removed before the drum can be sampled. This remote bung opener does not permit the slow venting of the container, and therefore appropriate precautions must be taken. It also requires the container to be upright and relatively level. Bungs that are rusted shut cannot be removed with this device.

7.6 Drum Sampling

After the drum has been opened, preliminary monitoring of headspace gases should be performed first with an explosimeter/oxygen meter. Afterwards, an OVA or other instruments should be used. If possible, these instruments should be intrinsically safe. In most cases it is impossible to observe the contents of these sealed or partially sealed drums. Since some layering or stratification is likely in any solution left undisturbed, a sample that represents the entire depth of the drum must be taken.



STANDARD OPERATING PROCEDURES

SOP: 2009
PAGE: 11 of 33
REV: 0.0
DATE: 11/16/94

DRUM SAMPLING

When sampling a previously sealed drum, a check should be made for the presence of a bottom sludge. This is easily accomplished by measuring the depth to apparent bottom then comparing it to the known interior depth.

7.6.1 Glass Thief Sampler

The most widely used implement for sampling drum liquids is a glass tube commonly referred to as a glass thief (Figure 7, Appendix B). This tool is cost effective, quick, and disposable. Glass thieves are typically 6mm to 16mm I.D. and 48 inches long.

Procedures for Use:

1. Remove the cover from the sample container.
2. Insert glass tubing almost to the bottom of the drum or until a solid layer is encountered. About one foot of tubing should extend above the drum.
3. Allow the waste in the drum to reach its natural level in the tube.
4. Cap the top of the sampling tube with a tapered stopper or thumb, ensuring liquid does not come into contact with stopper.
5. Carefully remove the capped tube from the drum and insert the uncapped end into the appropriate sample container.
6. Release stopper and allow the glass thief to drain until the container is approximately two-thirds full.
7. Remove tube from the sample container, break it into pieces and place the pieces in the drum.
8. Cap the sample container tightly and label it. Place the sample container into a carrier.
9. Replace the bung or place plastic over the drum.
10. Log all samples in the site logbook and on Drum/Tank Sampling Data Sheets.
11. Perform hazard categorization analyses if included in the project scope.
12. Transport the sample to the decontamination zone and package it for transport to the analytical laboratory, as necessary. Complete chain of custody records.

In many instances a drum containing waste material will have a sludge layer on the bottom. Slow insertion of the sample tube into this layer; then a gradual withdrawal will allow the sludge to act as a bottom plug to maintain the fluid in the tube. The plug can be gently removed and placed into the sample container by the use of a stainless steel lab spoon.



STANDARD OPERATING PROCEDURES

SOP: 2009
PAGE: 12 of 33
REV: 0.0
DATE: 11/16/94

DRUM SAMPLING

It should be noted that in some instances disposal of the tube by breaking it into the drum may interfere with eventual plans for the removal of its contents. The use of this technique should be cleared with the project officer or other glass thief disposal techniques should be evaluated.

7.6.2 COLIWASA Sampler

The Composite Liquid Waste Sampler (COLIWASA) and modifications thereof are equipment that collect a sample from the full depth of a drum and maintain it in the transfer tube until delivery to the sample bottle. The COLIWASA (Figure 8, Appendix B) is a much cited sampler designed to permit representative sampling of multiphase wastes from drums and other containerized wastes. One configuration consists of a 152 cm by 4 cm I.D. section of tubing with a neoprene stopper at one end attached by a rod running the length of the tube to a locking mechanism at the other end.

Manipulation of the locking mechanism opens and closes the sampler by raising and lowering the neoprene stopper. One model of the COLIWASA is shown in Appendix B; however, the design can be modified and/or adapted somewhat to meet the needs of the sampler.

The major drawbacks associated with using a COLIWASA concern decontamination and costs. The sampler is difficult to decontaminate in the field and its high cost in relation to alternative procedures (glass tubes) make it an impractical throwaway item. It still has applications, however, especially in instances where a true representation of a multiphase waste is absolutely necessary.

Procedures for Use

1. Put the sampler in the open position by placing the stopper rod handle in the T-position and pushing the rod down until the handle sits against the sampler's locking block.
2. Slowly lower the sampler into the liquid waste. Lower the sampler at a rate that permits the levels of the liquid inside and outside the sampler tube to be about the same. If the level of the liquid in the sample tube is lower than that outside the sampler, the sampling rate is too fast and will result in a non-representative sample.
3. When the sampler stopper hits the bottom of the waste container, push the sampler tube downward against the stopper to close the sampler. Lock the sampler in the closed position by turning the T-handle until it is upright and one end rests tightly on the locking block.
4. Slowly withdraw the sample from the waste container with one hand while wiping the sampler tube with a disposable cloth or rag with the other hand.
5. Carefully discharge the sample into the appropriate sample container by slowly pulling the lower end of the T-handle away from the locking block while the lower end of the sampler is positioned in a sample container.



STANDARD OPERATING PROCEDURES

SOP: 2009
PAGE: 13 of 33
REV: 0.0
DATE: 11/16/94

DRUM SAMPLING

6. Cap the sample container tightly and label it. Place the sample container in a carrier.
7. Replace the bung or place plastic over the drum.
8. Log all samples in the site logbook and on Drum/Tank Sampling Data Sheets.
9. Perform hazard categorization analyses if included in the project scope.
10. Transport the sample to the decontamination zone and package for transport to the analytical laboratory, as necessary. Complete the Chain of Custody records.

7.6.3 Coring Device

A coring device may be used to sample drum solids. Samples should be taken from different areas within the drum. This sampler consists of a series of extensions, a T-handle, and the coring device.

Procedures for use:

1. Assemble the sampling equipment.
2. Remove the cover from the sample container.
3. Insert the sampling device to the bottom of the drum. The extensions and the "T" handle should extend above the drum.
4. Rotate the sampling device to cut a core of material.
5. Slowly withdraw the sampling device so that as much sample material as possible is retained within it.
6. Transfer the sample to the appropriate sample container, and label it. A stainless steel spoon or scoop may be used as necessary.
7. Cap the sample container tightly and place it in a carrier.
8. Replace the bung or place plastic over the drum.
9. Log all samples in the site log book and on Drum/Tank Sampling Data Sheets.
10. Perform hazard categorization analyses if included in the project scope.
11. Transport the sample to the decontamination zone and package it for transport to the analytical laboratory, as necessary. Complete chain of custody records.

7.7 Hazard Categorization



STANDARD OPERATING PROCEDURES

SOP: 2009
PAGE: 14 of 33
REV: 0.0
DATE: 11/16/94

DRUM SAMPLING

The goal of characterizing or categorizing the contents of drums is to obtain a quick, preliminary assessment of the types and levels of pollutants contained in the drums. These activities generally involve rapid, non-rigorous methods of analysis. The data obtained from these methods can be used to make decisions regarding drum staging or restaging, bulking or compositing of the drum contents.

As a first step in obtaining these data, standard tests should be used to classify the drum contents into general categories such as auto-reactives, water reactives, inorganic acids, organic acids, heavy metals, pesticides, cyanides, inorganic oxidizers, and organic oxidizers. In some cases, further analyses should be conducted to more precisely identify the drum contents.

There are several methods available to perform these tests:

- the HazCat chemical identification system
- the Chlor-N-Oil Test Kit
- Spill-fyter Chemical Classifier Strips
- Setaflash (for ignitability)

These methods must be performed according to the manufacturers' instructions and the results must be documented on the Field Test Data Sheet for Drum/Tank Sampling (Attachment 2, Appendix A).

Other tests which may be performed include:

- Water Reactivity
- Specific Gravity Test (compared to water)
- Water Solubility Test
- pH of Aqueous Solution

The tests must be performed in accordance with the instructions on the Field Test Data Sheet for Drum/Tank Sampling and results of the tests must be documented on these data sheets.

The specific methods that will be used for hazard categorization must be documented in the Quality Assurance Work Plan.

8.0 CALCULATIONS

This section is not applicable to this SOP.

9.0 QUALITY ASSURANCE/QUALITY CONTROL

The following general quality assurance procedures apply:

1. All data must be documented on Chain of Custody records, Drum/Tank Sampling Data Sheets, Field Test Data Sheet for Drum/Tank Sampling, or within site logbooks.
2. All instrumentation must be operated in accordance with operating instructions as supplied by the manufacturer, unless otherwise specified in the work plan. Equipment checkout and calibration activities must occur prior to sampling/operation, and they must be documented.



STANDARD OPERATING PROCEDURES

SOP: 2009
PAGE: 15 of 33
REV: 0.0
DATE: 11/16/94

DRUM SAMPLING

10.0 DATA VALIDATION

This section is not applicable to this SOP.

11.0 HEALTH AND SAFETY

When working with potentially hazardous materials, follow U.S. EPA, OSHA, and corporate health and safety procedures.

More specifically, the opening of closed containers is one of the most hazardous site activities. Maximum efforts should be made to ensure the safety of the sampling team. Proper protective equipment and a general awareness of the possible dangers will minimize the risk inherent to sampling operations. Employing proper drum opening techniques and equipment will also safeguard personnel. The use of remote sampling equipment whenever feasible is highly recommended.

12.0 REFERENCES

Guidance Document for Cleanup of Surface Tank and Drum Sites, OSWER Directive 9380.0-3.

Drum Handling Practices at Hazardous Waste Sites, EPA-600/2-86-013.



STANDARD OPERATING PROCEDURES

SOP: 2009
PAGE: 16 of 33
REV: 0.0
DATE: 11/16/94

DRUM SAMPLING

APPENDIX A
Attachments
SOP #2009
November 1994



STANDARD OPERATING PROCEDURES

SOP: 2009
PAGE: 17 of 33
REV: 0.0
DATE: 11/16/94

DRUM SAMPLING

ATTACHMENT 1. Drum/Tank Sampling Data Sheet

Samplers: _____ Date: _____

Site Name: _____ Work Order Number: _____

Container Number/Sample Number: _____ REAC Task Leader: _____

SITE INFORMATION:

1. Terrain, drainage description: _____

2. Weather conditions (from observation): _____

MET station on site: No Yes

CONTAINER INFORMATION:

1. Container type: Drum Tank Other: _____

2. Container dimensions: Shape: _____

Approximate size: _____

3. Label present: No Yes: _____

Other Markings: _____

4. Spill or leak present: No Yes Dimensions: _____

5. Container location: (Circle one) N/A See MapOther:



STANDARD OPERATING PROCEDURES

SOP: 2009
PAGE: 18 of 33
REV: 0.0
DATE: 11/16/94

DRUM SAMPLING

ATTACHMENT 1. Drum/Tank Sampling Data Sheet (cont)

SAMPLE INFORMATION:

1. Description: _____ liquid _____ solid (_____ powder or _____ crystals) _____ sludge

2. Color: _____ Vapors: _____

Other: _____

3. Local effects present: (damage - environmental, aterial) _____

FIELD MONITORING:

1. PID: _____ Background (clean zone)
_____ Probe used/Model used
_____ Reading from container opening

2. FID: _____ Background (clean zone)
_____ Reading from container opening

3. Radiation Meter:
_____ Model used
_____ Background (clean zone)
_____ Reading from container opening

4. Explosimeter/Oxygen Meter:
_____ Oxygen level from container opening
_____ LEL level from container opening



STANDARD OPERATING PROCEDURES

SOP: 2009
PAGE: 19 of 33
REV: 0.0
DATE: 11/16/94

DRUM SAMPLING

ATTACHMENT 2. Field Test Data Sheet for Drum/Tank Sampling

Samplers: _____ Date: _____
Site Name: _____ Work Order Number: 3347-040-001-_____
Container Number/Sample Number: _____ REAC Task Leader: _____

SAMPLE MONITORING INFORMATION:

- PID: _____ Background (clean zone)
_____ Probe used/Model used
_____ Reading from sample
- FID: _____ Background (clean zone)
_____ Reading from sample
- Radiation Meter: _____ Model used
_____ Background (clean zone)
_____ Reading from sample
- Explosimeter/Oxygen Meter: _____ Oxygen level (sample)
_____ LEL level (sample)

SAMPLE DESCRIPTION:

_____ Liquid _____ Solid _____ Sludge _____ Color _____ Vapors

WATER REACTIVITY:

- Add small amount of sample to water: _____ bubbles _____ color change to _____
_____ vapor formation _____ heat _____ No Change



STANDARD OPERATING PROCEDURES

SOP: 2009
PAGE: 21 of 33
REV: 0.0
DATE: 11/16/94

DRUM SAMPLING

ATTACHMENT 2. Field Test Data Sheet for Drum/Tank Sampling (cont)

Moderately basic (9-11)	Dark GREEN
Strong Base (13-14)	Dark BLUE
2. Oxidizer Risk: (Circle one)	
Not Present	WHITE
Present	BLUE, RED, OR ANY DIVERGENCE FROM WHITE
3. Fluoride Risk: (Circle one)	
Not Present	PINK
Present	YELLOW
4. Petroleum Product, Organic Solvent Risk: (Circle one)	
Not Present	LIGHT BLUE
Present	DARK BLUE
5. Iodine, Bromine, Chlorine Risk: (Circle one)	
Not Present	PEACH
Present	WHITE OR YELLOW



STANDARD OPERATING PROCEDURES

SOP: 2009
PAGE: 22 of 33
REV: 0.0
DATE: 11/16/94

DRUM SAMPLING

ATTACHMENT 2. Field Test Data Sheet for Drum/Tank Sampling (cont)

SETAFLASH IGNITABILITY TEST:

140°F	Ignitable: _____	Non-Ignitable _____
160°F	Ignitable: _____	Non-Ignitable _____
_____	Ignitable: _____	Non-Ignitable _____
_____	Ignitable: _____	Non-Ignitable _____
_____	Ignitable: _____	Non-Ignitable _____
_____	Ignitable: _____	Non-Ignitable _____

Comments:

HAZCAT® KIT TESTS:

1. Test: _____ Outcome: _____

Comments: _____

2. Test: _____ Outcome: _____

Comments: _____



STANDARD OPERATING PROCEDURES

SOP: 2009
PAGE: 23 of 33
REV: 0.0
DATE: 11/16/94

DRUM SAMPLING

ATTACHMENT 2. Field Test Data Sheet for Drum/Tank Sampling (cont)

3. Test: _____ Outcome: _____

Comments: _____

4. Test: _____ Outcome: _____

Comments: _____

5. Test: _____ Outcome: _____

Comments: _____

HAZCAT® PESTICIDES KIT:

Present: _____ Not Present: _____

Comments: _____



STANDARD OPERATING PROCEDURES

SOP: 2009
PAGE: 24 of 33
REV: 0.0
DATE: 11/16/94

DRUM SAMPLING

APPENDIX B
Figures
SOP #2009
November 1994



STANDARD OPERATING PROCEDURES

SOP: 2009
PAGE: 25 of 33
REV: 0.0
DATE: 11/16/94

DRUM SAMPLING

Figure 1. Universal Bung Wrench

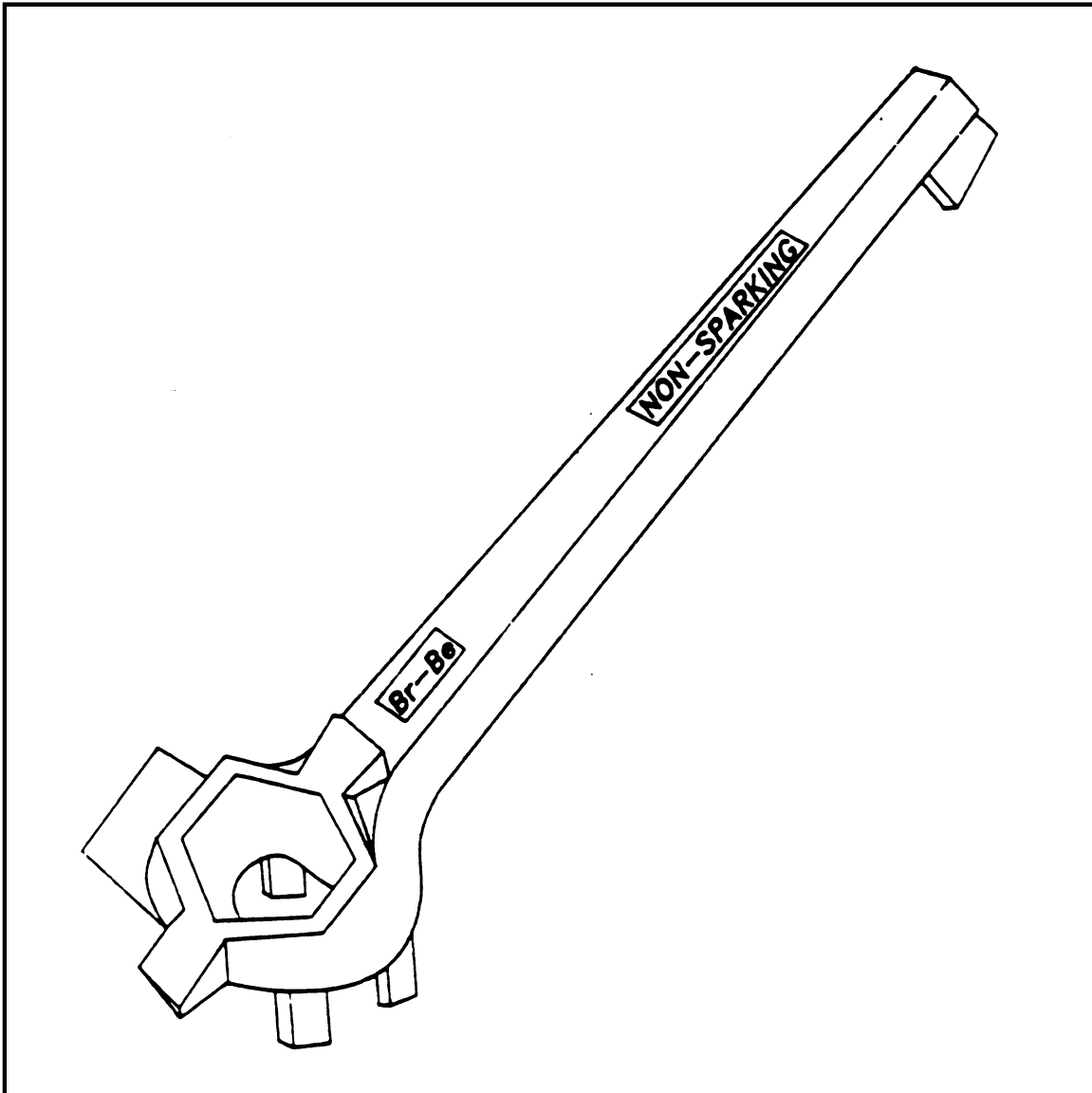



STANDARD OPERATING PROCEDURES

SOP: 2009
PAGE: 26 of 33
REV: 0.0
DATE: 11/16/94

DRUM SAMPLING

Figure 2. Drum Deheader

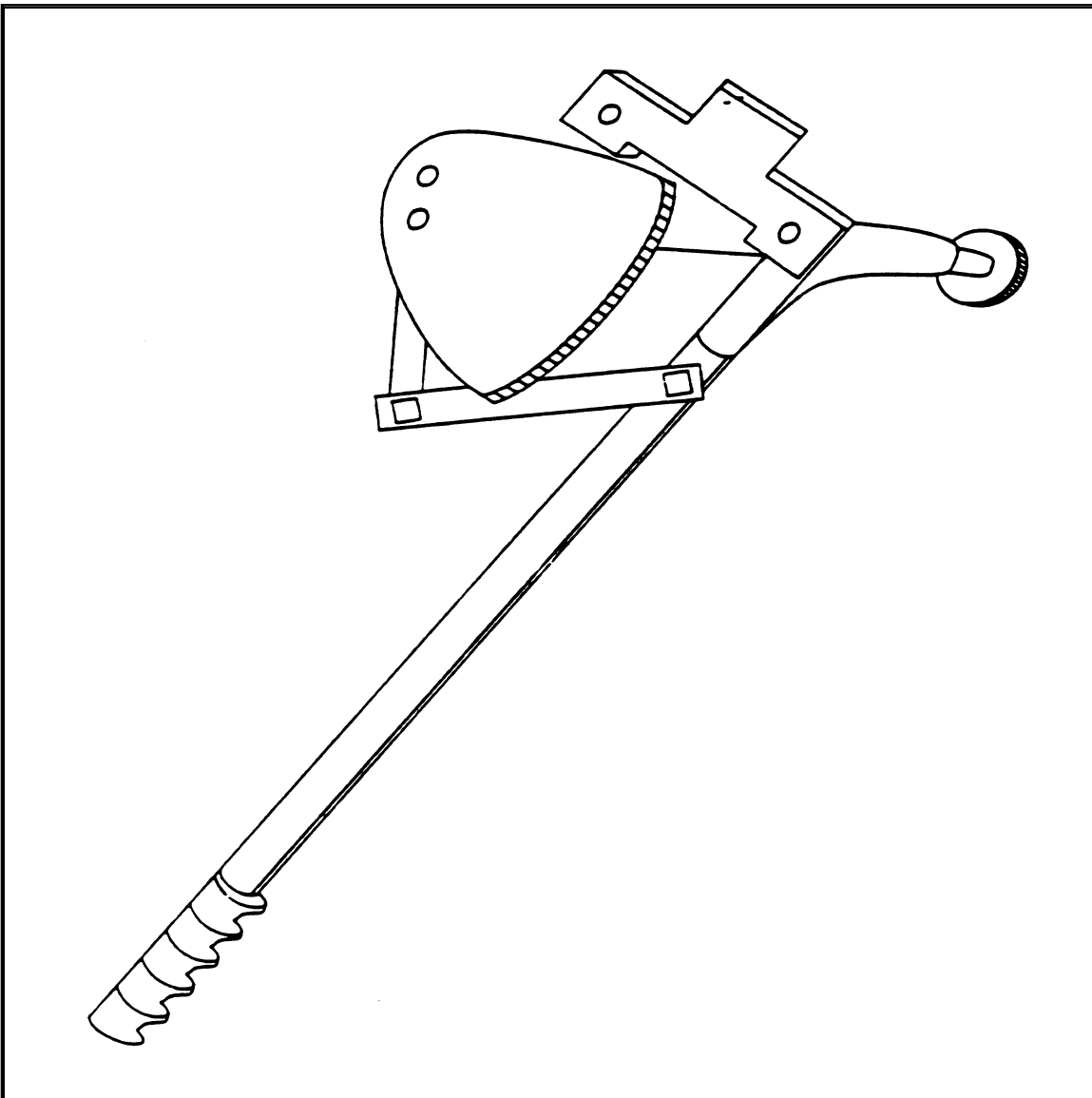



STANDARD OPERATING PROCEDURES

SOP: 2009
PAGE: 27 of 33
REV: 0.0
DATE: 11/16/94

DRUM SAMPLING

Figure 3. Hand Pick, Pickaxe, and Hand Spike

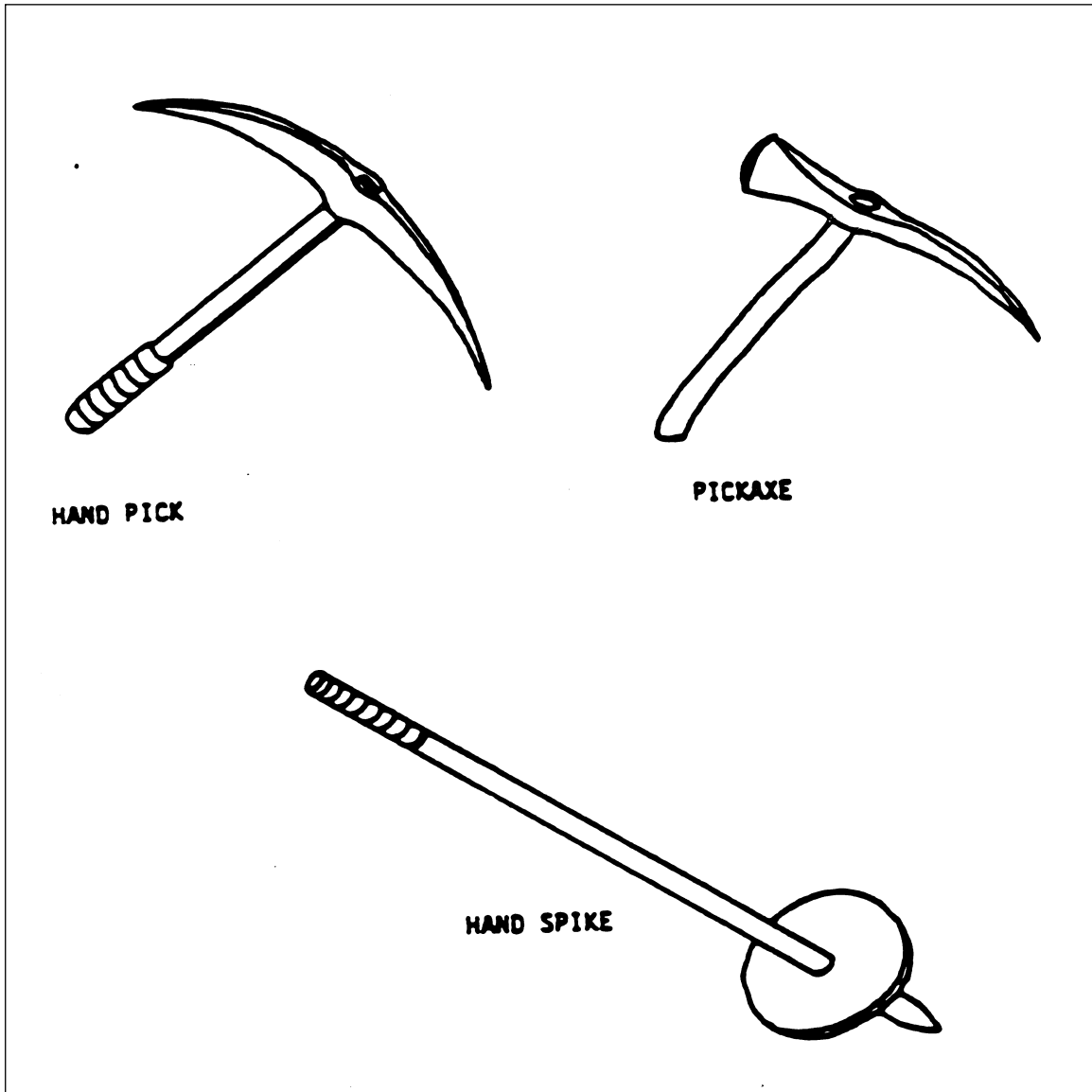



STANDARD OPERATING PROCEDURES

SOP: 2009
PAGE: 28 of 33
REV: 0.0
DATE: 11/16/94

DRUM SAMPLING

Figure 4. Backhoe Spike

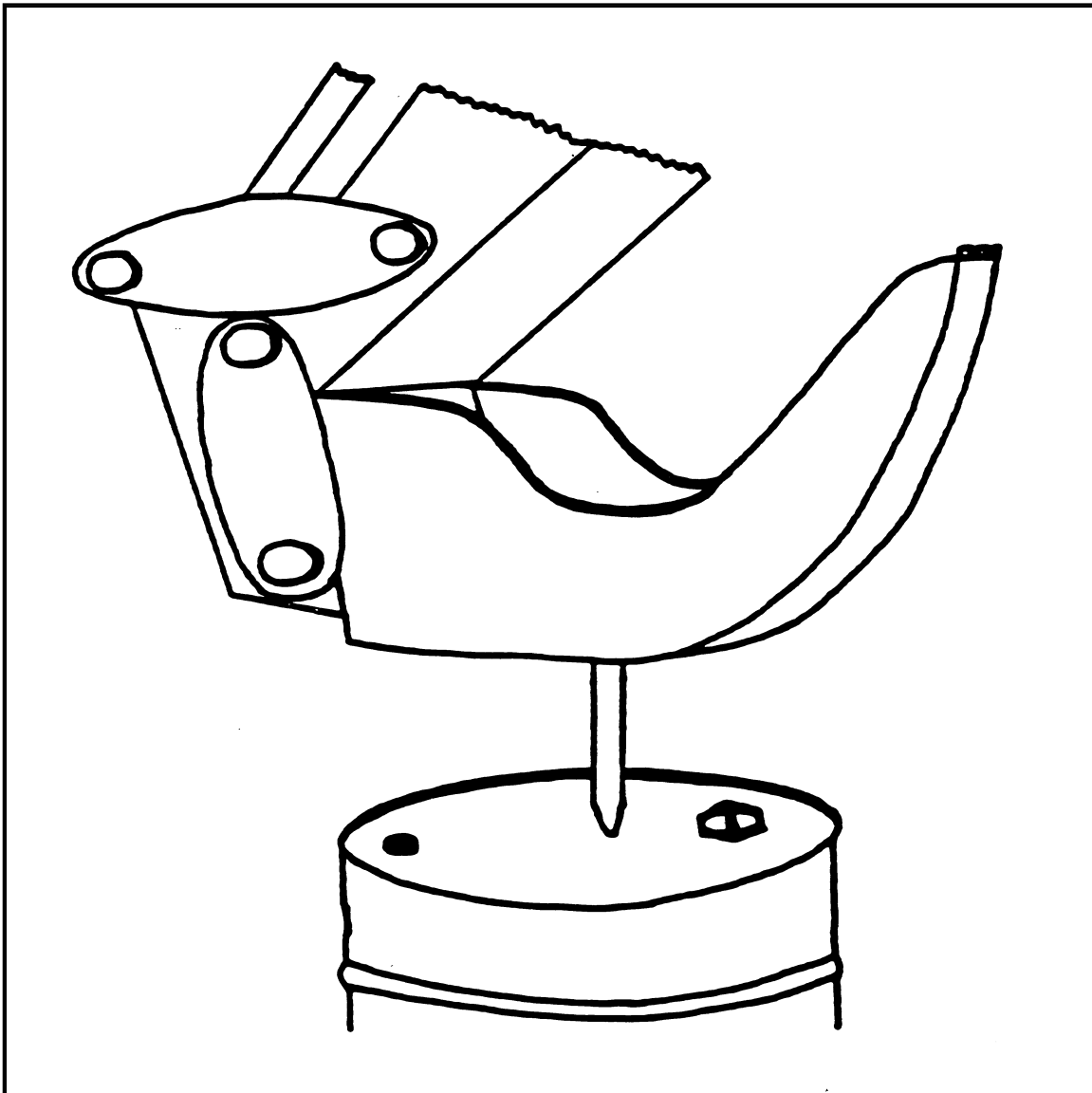



STANDARD OPERATING PROCEDURES

SOP: 2009
PAGE: 29 of 33
REV: 0.0
DATE: 11/16/94

DRUM SAMPLING

Figure 5. Hydraulic Drum Opener

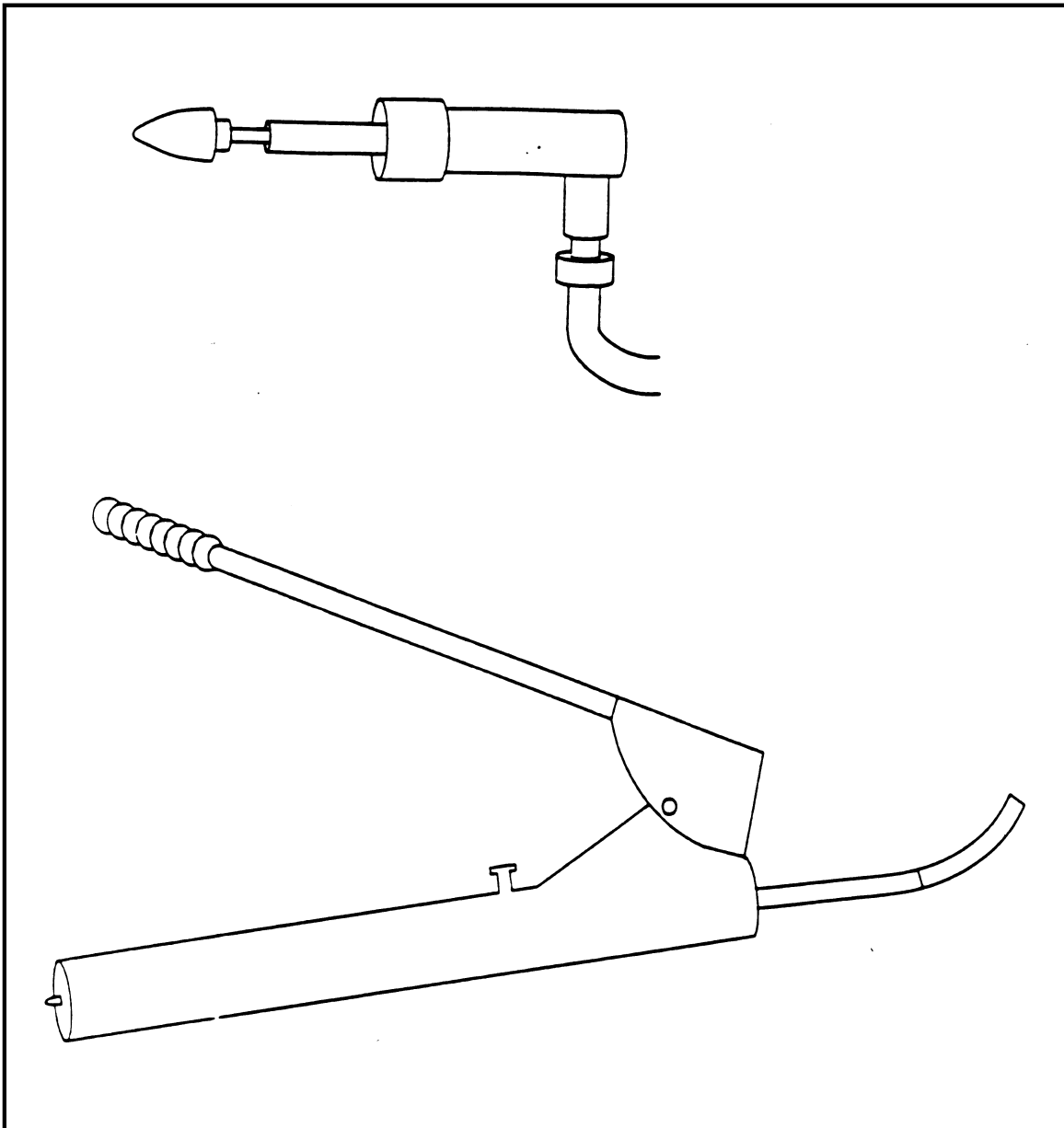



STANDARD OPERATING PROCEDURES

SOP: 2009
PAGE: 30 of 33
REV: 0.0
DATE: 11/16/94

DRUM SAMPLING

Figure 6. Pneumatic Bung Remover

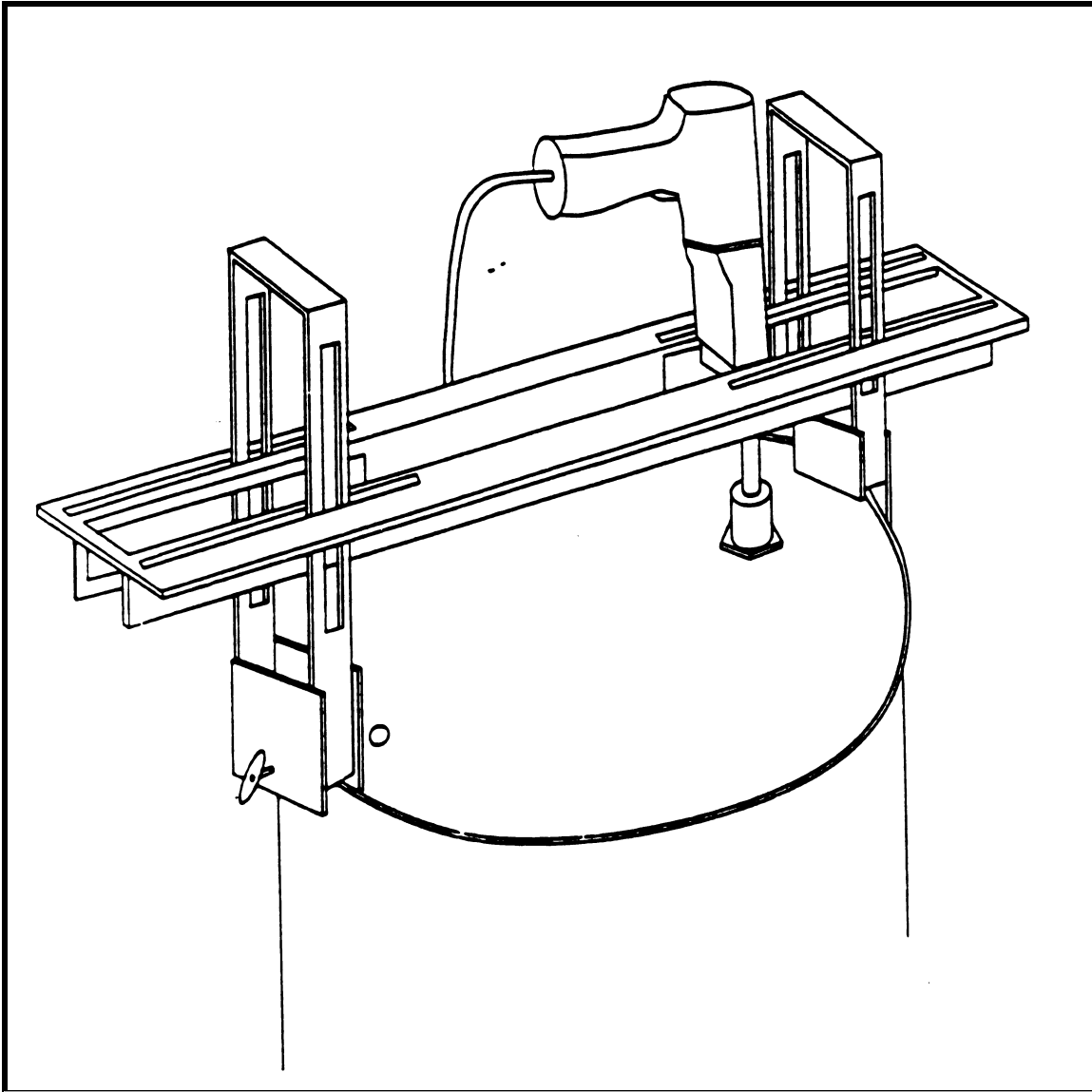



STANDARD OPERATING PROCEDURES

SOP: 2009
PAGE: 31 of 33
REV: 0.0
DATE: 11/16/94

DRUM SAMPLING

Figure 7. Glass Thief

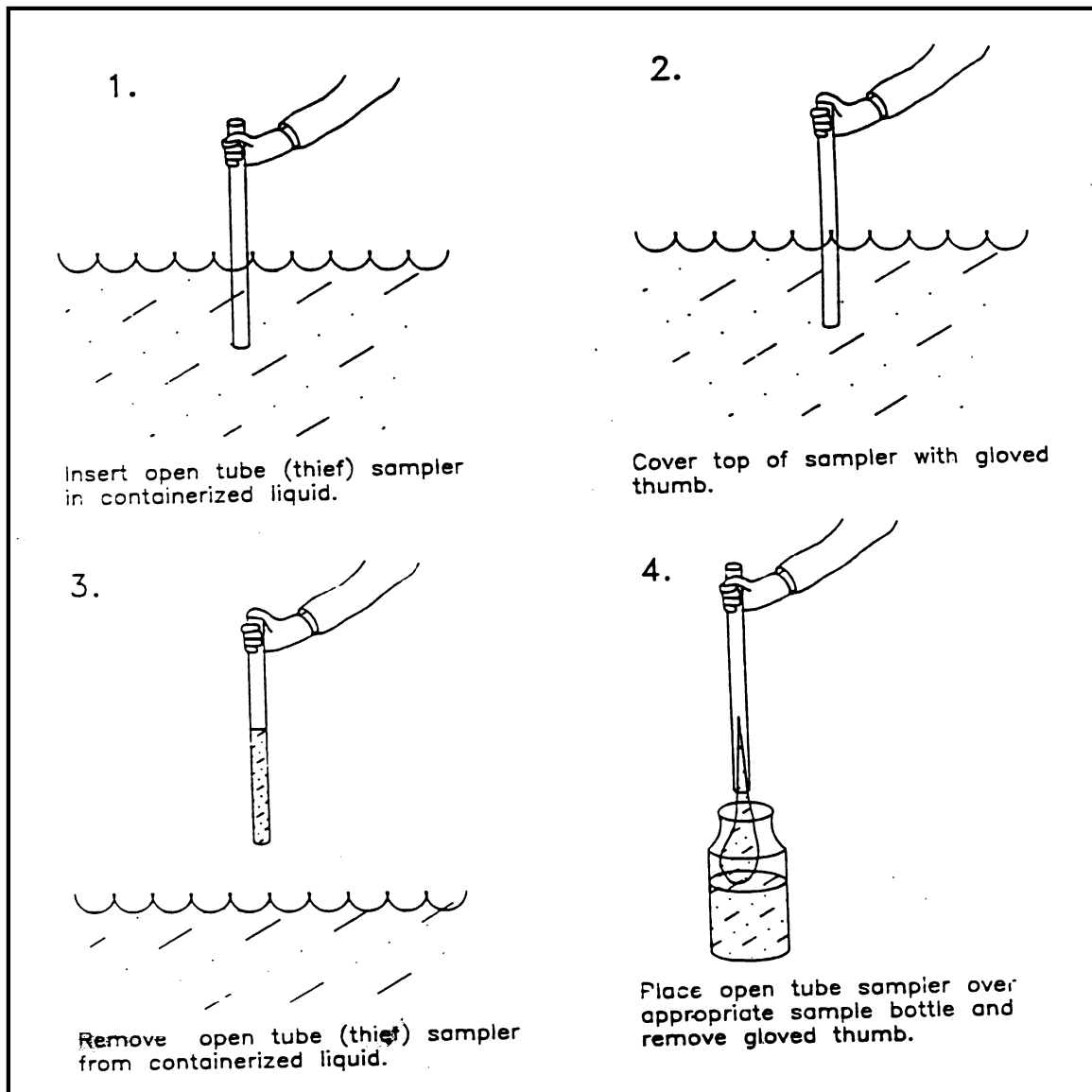



STANDARD OPERATING PROCEDURES

SOP: 2009
PAGE: 32 of 33
REV: 0.0
DATE: 11/16/94

DRUM SAMPLING

Figure 8. COLIWASA

