

STATE-OF-THE-PRACTICE OVERVIEW

Critical Evaluation of State-of-the-Art In Situ Thermal Treatment Technologies for
DNAPL Source Zone Treatment

ESTCP Project ER-0314

MAY 2009

Paul Johnson, Paul Dahlen and Jennifer Triplett
Kingston
Arizona State University

Eric Foote and Shane Williams
Battelle Memorial Institute

Approved for Public Release,
Distribution is Unlimited



Environmental Security Technology
Certification Program

**State-of-the-Practice Overview of the use of In Situ Thermal Technologies
for NAPL Source Zone Cleanup**

TABLE OF CONTENTS

Introduction	1
Introduction to In Situ Thermal Technologies	2
Electrical Resistance Heating.....	2
Thermal Conduction Heating/In Situ Thermal Desorption	3
Steam-Enhanced Extraction	4
Large-Diameter Auger Soil Mixing Combined with Steam/Hot Air Injection	6
Aboveground Treatment of Recovered Vapors and Liquids	7
Key Lessons Learned from Review of In Situ Thermal Remediation Projects Conducted from 1988–2007	8
Background.....	8
Overview of Available Documentation.....	8
Synthesis of Available Documentation.....	11
Settings in Which In Situ Thermal Technologies Have Been Applied	11
Basic Design Information Summary	12
Basic Operating Conditions Summary	13
Post-Treatment Impact of In Situ Thermal Treatment	14
Summary.....	18
References and Suggested Reading.....	20
Appendix A—State-of-the-Practice Technology Summaries Prepared by In Situ Thermal Remediation Vendors	
Electrical Resistance Heating	A-1
1.0 Overview of Technology	A-1
2.0 Energy Delivery/Heating Information.....	A-2
3.0 Process Configuration Information.....	A-8
4.0 Process Information	A-10
5.0 Technology Selection.....	A-10
Thermal Conduction Heating	A-12
1. Overview of Technology	A-12
2. Energy Delivery/Heating Information.....	A-12
3. Process Configuration Information.....	A-19
4. Process Information	A-22
5. Technology Selection.....	A-24
Steam-Enhanced Extraction	A-26
1. Overview of Technology	A-26
2. Energy Delivery/Heating Information.....	A-26
3. Process Configuration Information.....	A-33
4. Process Information	A-36
5. Technology Selection.....	A-39
Hot Air/Steam Injection Thermal Remediation Using Large Diameter	
Auger (LDA) In-Situ Soil Mixing.....	A-41
1. Overview of Technology	A-41
2. Energy Delivery/Heating Information.....	A-42
3. Process Configuration Information.....	A-50
4. Process Information	A-51
5. Technology Selection.....	A-53
Appendix B—Summary of Information Gathered on All In Situ Thermal Technology Applications	

FIGURES AND TABLES

Figure 1. Conceptual depiction of an ERH application	2
Figure 2. Conceptual depiction of a thermal conduction heating application	4
Figure 3. Conceptual depiction of a steam-enhanced extraction system	5
Figure 4. Conceptual depiction of an in situ soil mixing application	6
<hr/>	
Table 1. Summary of technology applications by technology type (1988-2007).....	9
Table 2. Summary of key information from in situ thermal applications conducted since 2000...	10
Table 3. Basic design information compiled for all sites reviewed.....	12
Table 4. Basic operating conditions summary for all applications reviewed.....	13
Table 5. Effect of application of in situ thermal technology on dissolved groundwater concentrations and mass discharge from treatment zone to the aquifer.....	14
Table 6. Characteristics of sites where detailed post-treatment sampling was conducted.....	15
Table 7. Range of permanent monitoring well pre- and post-treatment concentration data	16
Table 8. Summary of mass discharge calculations at field investigation sites	17

APPENDIX A

Electrical Resistance Heating

Figure 1. Conceptual depiction of the application of ERH	A-5
Figure 2. Applied power (kW) and temperature	A-6
Figure 3. Temperature monitoring showing average temperature versus time at the three monitoring locations	A-7
Figure 4. Typical equipment layout for ERH application	A-9

Thermal Conduction Heating

Figure 1. Conceptual sketch of in situ thermal desorption system	A-13
Figure 2. Typical timeline for operation of an ISTD system for VOC remediation	A-14
Figure 3. Generic layout of heater borings and process equipment for an ISTD project.....	A-19
Figure 4. Conceptual cross-section of an ISTD treatment zone	A-20
Figure 5. Example treatment system for fluids recovered during ISTD implementation	A-21
<hr/>	
Table 1. Typical duration of ISTD operation as a function of heater spacing	A-15

Steam-Enhanced Extraction

Figure 1. Conceptual sketch of steam-enhanced extraction system	A-27
Figure 2. Steam generation system schematic.....	A-27
Figure 3. Typical timeline for operation of an SEE system.....	A-28
Figure 4. Generic layout of heater borings and process equipment for an SEE project.....	A-33
Figure 5. Generic cross-section for an SEE site with one injection interval	A-34
Figure 6. Effluent treatment system.....	A-35
<hr/>	
Table 1. Typical duration of SEE operation as a function of well spacing	A-30

Hot Air/Steam Injection Thermal Remediation Using Large Diameter Auger In Situ Soil Mixing

Figure 1. Conceptual overview of the thermal treatment operation and equipment	A-43
Figure 2. Typical real-time operational display chart	A-45
Figure 3. Temperature/vapor pressure curve of water	A-47
Figure 4. Typical display of key operational parameters	A-49
Figure 5. Typical cell layout surface view and Kelly cross section.....	A-50
<hr/>	
Table 1. List of measured and displayed operational parameters	A-45
Table 2. Data for two important azeotropes	A-48
Table 3. Example of LDA thermal treatment completion criteria.....	A-52

ACRONYMS AND ABBREVIATIONS

ASU	Arizona State University
atm	atmosphere
bgs	below ground surface
CFM	cubic feet per minute
COC	contaminant of concern
CVOC	chlorinated volatile organic compound
DAS	Data Acquisition System
DCE	dichloroethene
DNAPL	dense, non-aqueous phase liquid
DoD	Department of Defense
DOE	Department of Energy
EGDY	East Gate Disposal Yard
EPA	Environmental Protection Agency
ERH	electrical resistance heating
ESTCP	Environmental Security Technology Certification Program
FID	flame ionization detector
GAC	granular activated carbon
GC	gas chromatograph
H&S	health and safety
IPTD	in-pile thermal desorption
ISTD	in situ thermal desorption
ISTD	in situ thermal desorption
LDA	large-diameter auger
LNAPL	light non-aqueous phase liquid
MCL	maximum contaminant level
MNA	monitored natural attenuation
MGP	manufactured gas plant
NAPL	non-aqueous phase liquid
NAS	Naval Air Station
NPDES	National Pollutant Discharge Elimination System (US EPA)
PAH	polycyclic aromatic hydrocarbon
PCB	polychlorinated biphenyl
PCU	power control unit
POTW	publicly owned treatment works
psia	pounds per square inch absolute
psig	pounds per square inch gauge
RFH	radio frequency heating
SDC	supplemental data collection
SEE	steam-enhanced extraction
SVE	soil vapor extraction
SVOC	semi-volatile organic compound
TCE	trichloroethene
TCH	thermal conduction heating
TDS	total dissolved solids
TPHC	total petroleum hydrocarbon content
TRS	Thermal Remediation Services, Inc.
USACE	U.S. Army Corps of Engineers
VOC	volatile organic compound
VR	vapor recovery
ZVI	zero valent iron

Acknowledgments

The authors would like to thank Environmental Security Technology Certification Program (ESTCP) for the project funding and the following organizations for their help in data collection: TerraTherm, Current Environmental Solutions, Thermal Remediation Services, McMillan-McGee, the Navy, the Air Force, the National Air Reserve, Shaw Environmental, Inc. , Haley and Aldrich, ERM, the Army Corps of Engineers (USACE), the Environmental Protection Agency, the Department of Defense, the Department of Energy, and numerous other consulting firms involved in thermal applications that helped us with documentation. We would also like to thank the following people for helping us gain access to the field sites: Ronald Kenyon (Shaw), Daniel Hood (Navy), Bob Lowder (Marines), Steven Peck (Navy), Doug DeLong (Navy), John McGuire (Shaw), Richard Wice (Shaw), George Walters (Air Force), Randall McDaniel (Shaw), Phil La Mori (BEM Systems), Mark Kershner (Air Force), Emile Pitre (USACE), Kira Lynch (USACE), and Algeana Stevenson (DPW Environmental).

Additionally, we would like to thank the following people for their help during this project: Eva Davis, Ralph Baker, Gorm Heron, Gregory Crisp, Michael Basel, Dave Becker, David Fleming, Bill Heath, Jim Cummings, Sam Yoon, Glenna Clark, Gerald Hromowyk, Tony Landler, Craig Eaker, Ana Vergara, Wayesheu, Ray Kasevich, Michael Pound, David Parse, Mark Lyverse, Steve Langford, Steven Kawchak, Joseph Amari, James Kupar, Jack Craig, Quintin Hughes, Steven Faryan, Derek Peacock, Dean Williamson, Robert Davis, David Rountree, David Scaturo, David Ingle, David Chiusano, Dacre Bush, Craig Holloway, Denis Conley, Chris Bozzini, Chad Northington, Brett Berra, Tim Ault, and numerous other individuals who helped along the way.

Introduction

In situ thermal technologies have undergone rapid development and application in recent years as they promise the potential of quicker and more thorough treatment of non-aqueous phase liquid (NAPL) source zones. These technologies include electrical resistance heating (ERH), conductive heating/in situ thermal desorption (ISTD), steam-enhanced extraction (SEE), radio frequency heating (RFH), and large-diameter auger (LDA) soil mixing combined with steam/hot air injection. Each involves raising the subsurface temperature to achieve contaminant removal by some combination of the following: a) viscosity reduction to enhance mobility and liquid removal by pumping, b) vapor pressure increase (and in some cases in situ steam generation) to enhance removal by vapor extraction, and c) increased reaction rate (i.e., biodegradation or in situ oxidation) to destroy contaminants in situ.

Thermal technologies have attracted the interest of responsible parties and regulators, especially in those cases where quicker cleanups are desired or where subsurface heterogeneities are likely to significantly limit the performance of other in situ treatment alternatives. Vendors assert that some site cleanups can occur in much less than a year and that the performance of thermal technologies (in particular ERH, ISTD, and in situ soil mixing/heating) is less sensitive to the geologic stratification/heterogeneity that limits other in situ remediation technologies.

Because of the growing interest and application of in situ thermal remediation technologies, Environmental Security Technology Certification Program (ESTCP) funded the study *Critical Evaluation of State-of-the-Art In Situ Thermal Treatment Technologies for DNAPL Source Zone Treatment (ER-0314)*. This document is one of the products of that work. It is intended to be a useful tool and primer for program managers considering the use of thermal technologies at their sites.

This document is divided into three main sections:

- Brief introductions to the most commonly applied in situ thermal technologies
- Summaries of key information gained from review of 182 thermal applications conducted from 1988 to 2007, emphasizing the subsurface settings, system designs, operating conditions, and performance—with the latter focused on groundwater quality improvement
- An appendix containing more in-depth discussion of the state-of-the-practice for ERH, ISTD, steam/hot air injection, and in situ soil mixing combined with steam/hot air injection, authored by technology vendors.

References are also included at the end of the main body of the report for those seeking additional knowledge and perspectives on these technologies.

Introduction to In Situ Thermal Technologies

A brief introduction to the more frequently used in situ thermal technologies is provided below. More in-depth discussions, authored by technology vendors, are contained in Appendix A. Other reference documents that may be of interest are also listed in the References section at the end of the main body of this document.

Electrical Resistance Heating

ERH achieves heating of the soil by passing electrical current through the soil between a network of electrodes, as shown in Figure 1. The lateral and vertical positioning of the electrodes, the voltage difference applied between electrodes and the electrical resistance of the soil determine the electrical current strength and path, and ultimately the energy delivery and heating pattern in the subsurface. The electrodes are often positioned in hexagonal or triangular arrays and six- or three-phase electricity is applied to the arrays. A network of vapor and liquid recovery wells is also installed to extract contaminant vapors and liquids from the subsurface.

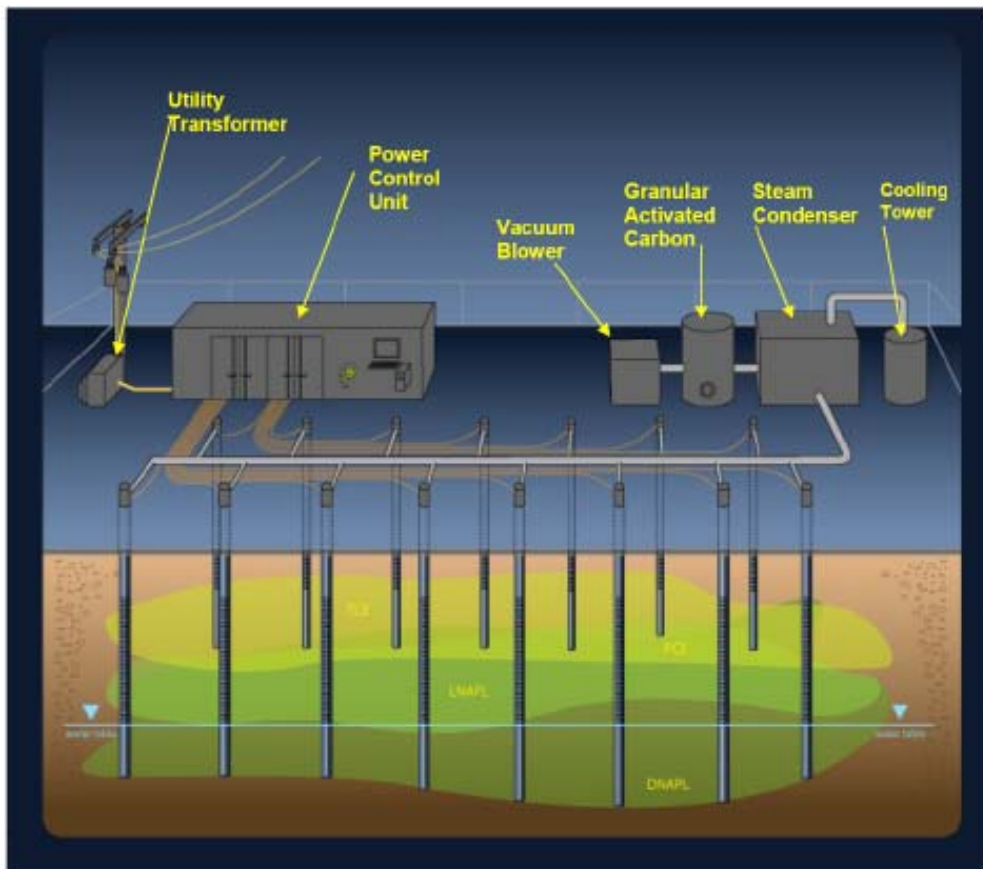

Figure 1. Conceptual depiction of an ERH application (from Appendix A: Smith, 2008)

ERH can heat the subsurface to temperatures up to about the boiling point of water (100° C at 1 atm pressure). Low-permeability silts and clay lenses and chlorinated solvent source areas can have a higher electrical conductivity, and if so, this leads to preferential heating of those zones, which is often desirable. There are factors that can limit the effectiveness of the heating, the main two being moisture loss and groundwater flow. The former is of concern because electrical resistance increases (electrical conductivity decreases) as soil moisture decreases, thereby resulting in reduced energy delivery to drier portions of the target treatment zone. Because of this, ERH systems sometimes incorporate wetting systems around the electrodes and in the targeted treatment area. In cases where treatment is targeted below the water table, groundwater flow carries warm water and energy out of the treatment zone and replaces it with cooler water. This energy sink can sometimes be significant and limit the heating of the target treatment zone. It can be mitigated, however, with the design and installation of a groundwater management system consisting of groundwater extraction and injection wells.

Process monitoring typically focuses on power delivery (current and voltage measurements), verification of heating (temperature monitoring throughout the target treatment zone), verification of contaminant containment (soil gas pressure and fluid elevation within and surrounding the target treatment zone), and instantaneous and cumulative mass removal rate (flows and concentrations in recovered vapor and liquid streams).

Thermal Conduction Heating/In Situ Thermal Desorption

ISTD achieves heating of the soil by thermal conduction and fluid convection away from networks of electric heating elements installed vertically in the soil or horizontally on the ground surface for cases of shallow soil contamination (<1 m bgs). The heaters typically operate at temperatures above 500°C (900°F). As with ERH, a network of vapor and liquid recovery wells is also installed to extract contaminant vapors and liquids from the subsurface. Figure 2 illustrates a conceptual layout of an ISTD system.

A unique feature of ISTD, relative to other thermal remediation technologies, is the potential to achieve subsurface temperatures well above the boiling point of water (100° C at 1 atm pressure), provided that all the moisture can be boiled away from the treatment zone. As with ERH, treatment below the water table can be limited by heat losses resulting from groundwater flow entering and leaving the treatment zone, and this can also be mitigated with the design and installation of a groundwater management system consisting of groundwater extraction and injection wells.

Process monitoring typically focuses on power delivery (current and voltage to the heaters), verification of heating (temperature monitoring throughout the target treatment zone), verification of contaminant (soil gas pressure and fluid elevation within and surrounding the target treatment zone), and instantaneous and cumulative mass removal rate (flows and concentrations in recovered vapor and liquid streams).

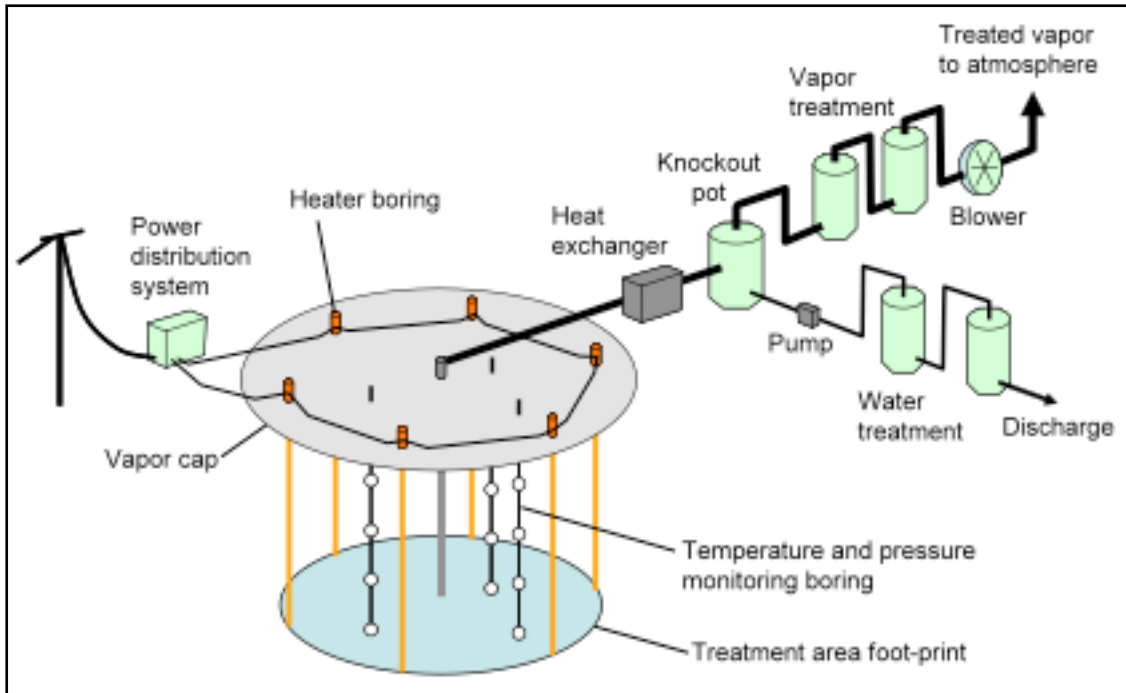

Figure 2. Conceptual depiction of a thermal conduction heating application (From Appendix A: Heron and Baker, 2008)

Steam-Enhanced Extraction

SEE involves the injection of steam under pressure into the subsurface and the recovery of liquids and vapors through a network of injection and extraction wells. In the early stages of the process, the injected steam displaces existing liquids (i.e., groundwater, if injected below the water table) and vapors, and heating occurs as energy is transferred from the steam to the formation. This energy transfer to the formation produces a steam condensate front that moves out from the injection wells and is followed by a steam zone, the movement and geometry of which is controlled by the steam injection rate, subsurface permeability to vapor and liquid flow, buoyancy effects, and the positioning of the injection and extraction wells. Figure 3 presents the conceptual layout of a typical SEE system. If well designed and operated, the process ultimately creates a steam zone throughout the treatment zone. Once that condition is reached, the steam injection pressure and rate may be increased and decreased in a cyclical fashion to promote volatilization from zones not actively swept by the steam flow. Sometimes steam and hot air are blended and injected.

Like ERH, SEE is limited to temperatures at or about the boiling point of water. Unlike ERH and ISTD, energy delivery relies on fluid flow, so the initial heating occurs along the steam flow path, which is largely dictated by the structure and properties of the subsurface. Energy transfer and heating of other regions must then occur by conduction away from the primary steam flow path.

Process monitoring typically focuses on energy balances (power used to produce steam vs. heat delivered and recovered), verification of heating (temperature monitoring throughout the target treatment zone), verification of contaminant (soil gas pressure and fluid elevation within and surrounding the target treatment zone), and instantaneous and cumulative mass removal rate of contaminant and water (flows and concentrations in recovered vapor and liquid streams).

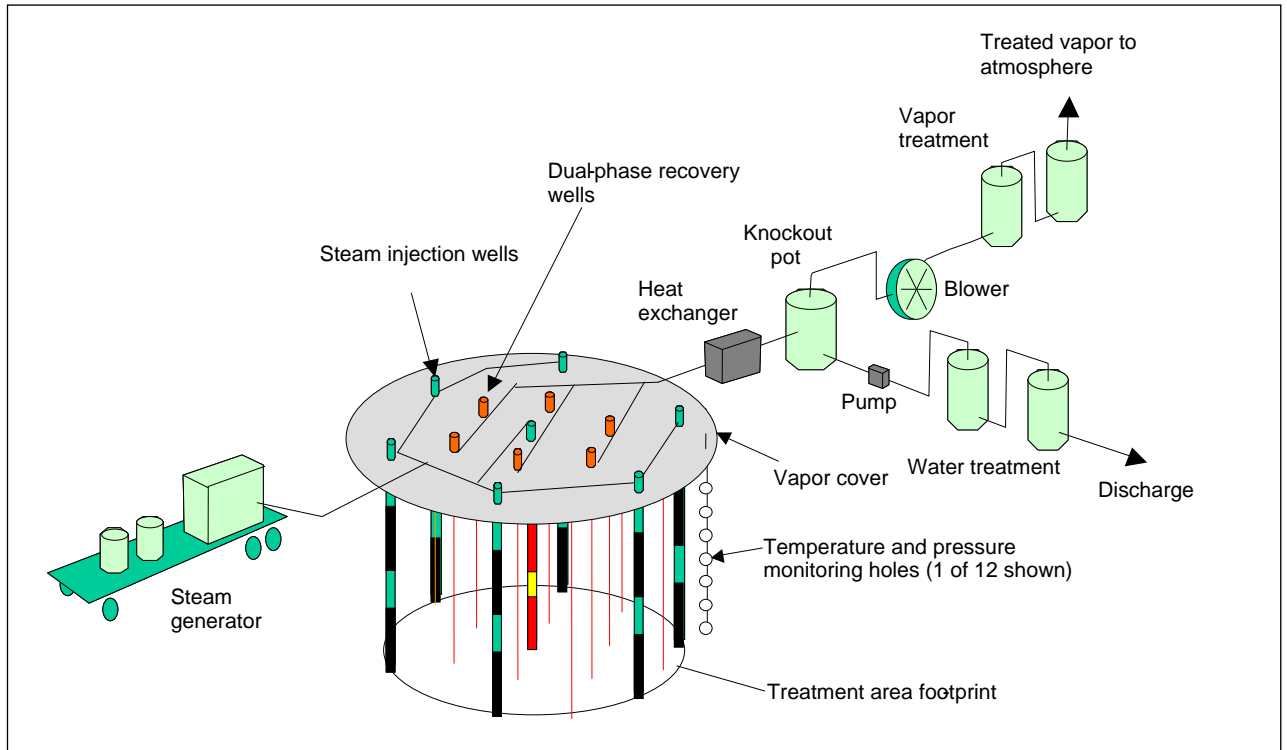

Figure 3. Conceptual depiction of a Steam-enhanced extraction system (from Appendix A: Heron 2008)

Large-Diameter Auger Soil Mixing Combined with Steam/Hot Air Injection

This technology involves the injection of steam, hot air, and occasionally reacting agents (i.e., zero-valent iron particles) through 6- to 10-ft diameter augers as they are slowly advanced into the subsurface. The augers act to break up the soil structure and increase the permeability. The injected steam and hot air heat the soil to temperatures approaching the boiling point of water (100° C). A shroud placed at ground surface covers the treatment area and is kept under vacuum to capture the liberated contaminant vapors. The process is operated in a batch mode, with movement of the auger across the treatment zone in an overlapping treatment pattern. Figure 4 presents a conceptual layout of an in situ soil mixing application.

Process monitoring typically focuses on instantaneous and cumulative mass removal rate of contaminant and water (flows and concentrations in recovered vapor stream).

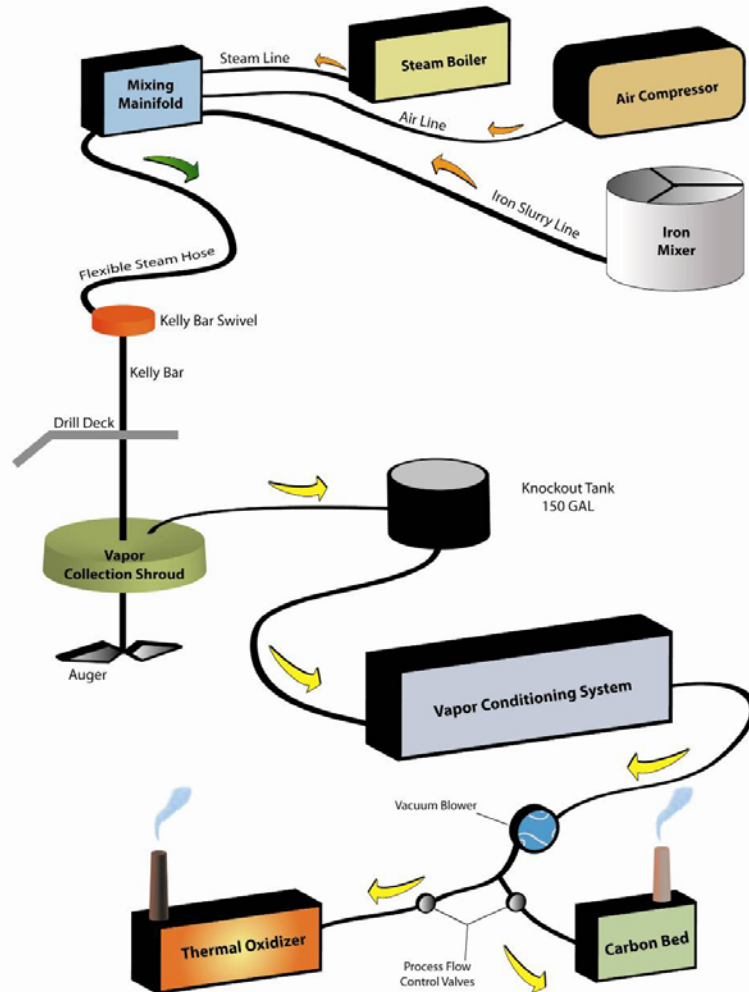

Figure 4. Conceptual depiction of an in situ soil mixing application (from Appendix A: La Mori and Kirkland, 2008)

Aboveground Treatment of Recovered Vapors and Liquids

As seen in Figures 1 through 4, in situ thermal treatment processes are coupled with aboveground treatment systems for the recovered vapor and liquid streams. Typically this involves some combination of condensation (i.e., knock-out pots), adsorption (i.e., carbon beds), and destruction (i.e., thermal and catalytic oxidizers) processes.

Key Lessons Learned from Review of In Situ Thermal Remediation Projects Conducted from 1988–2007

Background

The performance of thermal technologies was assessed through compilation and critical review of data available from pilot- and full-scale applications conducted from 1988–2007. Particular emphasis was placed on gaining a better understanding of settings in which thermal technologies have been applied, the design and operating conditions that were used, and the performance of the systems. With respect to the latter, particular emphasis was placed on post-treatment groundwater quality and source zone residual mass discharge to the aquifer (commonly referred to as “mass flux”).

Overview of Available Documentation

The in situ thermal treatment application data were obtained from a variety of sources, including site reports, published literature, U.S. Environmental Protection Agency (USEPA) cost and performance reports, discussions with project managers, vendors, and consultants, and unpublished data and observations. Sites for which data were collected encompassed in situ thermal technology applications worldwide and included ERH, steam with and without hot water injection, hot air injection, conductive heating, RFH, and LDA mixing with steam.

For each technology application studied, emphasis was placed on identifying:

- The setting (geology, depth to groundwater, source zone boundaries, chemicals present, etc.)
- System design parameters (number of energy delivery points, area and depth of the treatment zone, etc.)
- Operating conditions (temperature achieved, duration of treatment, duration of monitoring, etc.)
- Performance data (emphasizing improvement in groundwater quality and reduction in mass discharge of contaminant to the aquifer).

Capture of this data involved data interpretation and the use of professional judgment, especially when comparing pre- and post-treatment groundwater impacts.

A total of 182 in situ thermal treatment technology applications at 163 different sites were identified in this study. Table 1 presents the number of in situ thermal applications by technology. It also indicates how many were full-scale vs. pilot-scale applications and how many occurred since 2000. As can be seen, about half of all applications (98 of 182) were implemented at full-scale, with roughly half of those (56 of the 98) being ERH systems. Table 1 also shows that 84 of 182 applications (46%) have been implemented since 2000, over half (57%) of which were ERH systems. ERH applications outnumber

all other applications since 2000 by about a factor of three, and there also seems to be a recent trend in increasing use of conductive heating and decreasing use of steam heating.

Table 9. Summary of technology applications by technology type (1988-2007)

Technology	Number of Applications	Pilot-Scale*	Full-Scale*	Number Since Year 2000
Steam-Based	46	26	19	15
Electrical Resistance Heating	87	23	56	48
Conduction	26	12	14	17
Other/Radio-Frequency	23	14	9	4
Total	182	75	98	84

* Some sites have an unknown application size and thus are not included in the pilot- and full-scale count.

The quantity and quality of information available for each application varied; of note are the following observations:

- Sufficient data were available to identify the target chemicals of concern at 159 of 182 sites (87%).
- Sufficient data were available to identify the treatment area for 62 of 182 sites (34%) and the density of energy delivery points at 57 of 182 sites (31%); these are basic system design parameters that were compiled in this study.
- Sufficient data were available to identify the peak temperature at 49 of 182 sites (27%) and the duration of heating at 59 of 182 sites (32%); these are basic operational parameters that were compiled in this study.
- Post-treatment groundwater monitoring data were available for only 14 of 182 sites (8%); these are the basic performance data that were compiled in this study.

Thus, while there have been a large number of thermal treatment applications (at least 182), the data collected suggest that many have been poorly documented. This document, therefore, can provide insight to the range of settings to which thermal technologies have been applied, the designs that have been applied, and the operating conditions. However, it cannot provide much information on the actual performance of these technologies since the long-term effect on groundwater quality improvements and source zone discharge reductions appears to be poorly documented and/or not monitored at many thermal treatment sites.

Table 10. Summary of key information from in situ thermal applications conducted since 2000

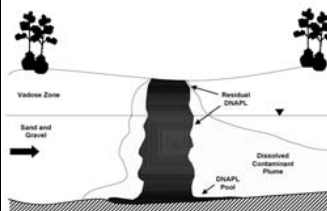
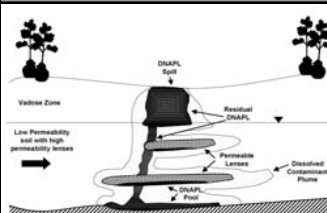
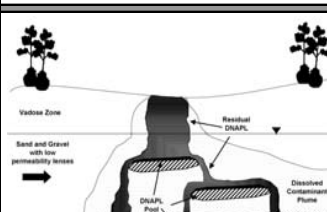
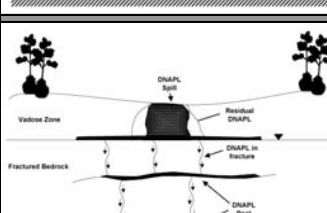
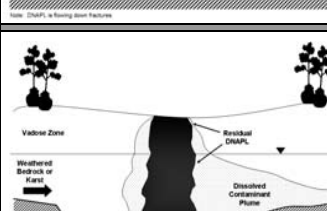
Generalized Conceptual Scenario	Technology	Total Sites		Chemical(s) Treated				Design Parameters				Operating Parameters						Performance Measures						Name(s) of Example Well-Studied Sites													
		# of Sites		# of Sites Treating These Chemicals (C-chlorinated solvents, P-petroleum hydrocarbons, W-wood treating, O-other)				# of Sites With Target Treatment Zones With Sizes In This Range [ft²]				# of Sites With Target Temperature in These Ranges [C]						Sites With Final Dissolved Concentrations Generally In This Range [ug/L]																			
		Pilot Tests	Full-Scale	C	P	W	O	<10 ⁴	10 ⁴ - 4x10 ⁴	<4x10 ⁴	<0.25	0.25-0.50	>0.5	<80	80 - 110	>110	<0.5	0.5 - 1.0	>1.0	<0.5	0.5 - 2.0	>2.0	<10		10 - 100	100 - 1000	10X	100X	1000X	<1	1.0 - 10	>10	10X	100X	1000X		
Generalized Scenario A: relatively homogeneous and permeable unconsolidated sediments (mixtures of sands, gravels and silts, etc.) 	SEE	1	0	0	1	0	0	1	0	0	1	0	0	0	0	0	0	1	0	0	0	0	0	1	1	0	0	0	0	0	0	0	0	0	0	Guadalupe	
	ERH	0	1	0	1	0	1	1	1	0	0	1	1	0	3	0	1	0	0	0	0	1	0	0	1	1	0	0	1	0	0	0	1	0	0	Hunter Army Airfield	
	ISTD	1	4	4	3	0	1	2	1	0	0	0	0	3	0	2	2	1	2	0	0	1	0	0	1	0	0	1	0	0	0	0	0	0	0		
	Other	0	0	0	0	0	0	0	0	0	0	0	0	0	0	0	0	0	0	0	0	0	0	0	0	0	0	0	0	0	0	0	0	0	0		
Generalized Scenario B: largely impermeable sediments with interbedded layers of higher permeable material 	SEE	1	1	2	0	0	0	1	0	0	1	0	0	0	1	0	1	0	1	1	0	0	0	1	0	1	0	0	0	0	0	0	0	0			
	ERH	6	18	16	9	1	1	14	7	0	3	8	9	3	10	0	11	7	2	1	0	0	0	1	1	5	2	2	3	0	0	1	1	0	0	Air Force Plant 4	
	ISTD	3	7	7	1	2	2	7	3	0	0	1	9	0	7	2	1	5	2	0	0	0	0	0	2	0	2	0	0	0	0	0	0	0	0	0	Alhambra Pole Yard
	Other	0	0	0	0	0	0	0	0	0	0	0	0	0	0	0	0	0	0	0	0	0	0	0	0	0	0	0	0	0	0	0	0	0	0		
Generalized Scenario C: largely permeable sediments with interbedded lenses of low permeable material 	SEE	3	3	3	2	1	1	2	2	1	4	0	0	2	2	0	2	0	3	0	0	0	0	0	1	1	0	0	0	0	0	0	0	0	0	Visalia, Lawrence Livermore National Laboratory	
	ERH	2	13	14	5	0	0	4	9	0	1	4	8	1	11	0	8	4	1	0	2	0	0	0	0	9	7	1	1	2	4	2	6	2	0	NAS Alameda Site 5-1 ERH, Young Rainey Star, Ft. Lewis Areas 1, 2, and 3	
	ISTD	0	0	0	0	0	0	0	0	0	0	0	0	0	0	0	0	0	0	0	0	0	0	0	0	0	0	0	0	0	0	0	0	0	0		
	Other	1	2	3	3	0	0	1	2	0	0	0	0	0	0	0	0	0	0	0	0	0	0	0	2	0	0	0	2	0	0	0	0	0	0	Cape Canaveral Air Force Station	
Generalized Scenario D: competent, but fractured bedrock 	SEE	2	1	3	1	0	0	2	0	0	1	0	1	1	1	0	3	0	0	1	0	0	0	0	2	2	0	0	1	0	0	1	0	0	Edwards Air Force Base, Loring Air Force Base		
	ERH	0	0	0	0	0	0	0	0	0	0	0	0	0	0	0	0	0	0	0	0	0	0	0	0	0	0	0	0	0	0	0	0	0			
	ISTD	0	0	0	0	0	0	0	0	0	0	0	0	0	0	0	0	0	0	0	0	0	0	0	0	0	0	0	0	0	0	0	0	0	0		
	Other	0	1	1	0	0	0	0	0	0	0	0	0	0	0	0	0	0	0	0	0	0	0	0	0	0	0	0	0	0	0	0	0	0	0		
Generalized Scenario E: weathered bedrock 	SEE	0	0	0	0	0	0	0	0	0	0	0	0	0	0	0	0	0	0	0	0	0	0	0	0	0	0	0	0	0	0	0	0				
	ERH	0	0	0	0	0	0	0	0	0	0	0	0	0	0	0	0	0	0	0	0	0	0	0	0	0	0	0	0	0	0	0	0	0			
	ISTD	1	0	1	1	0	0	1	0	0	0	0	1	0	1	0	1	0	0	0	0	0	0	0	0	0	0	0	0	0	0	0	0	0	0		
	Other	0	0	0	0	0	0	0	0	0	0	0	0	0	0	0	0	0	0	0	0	0	0	0	0	0	0	0	0	0	0	0	0	0	0		
Unknown Scenario	SEE	1	2	2	1	1	0	0	0	0	0	0	0	1	0	0	0	0	0	0	0	0	0	0	0	0	0	0	0	0	0	0	0	0			
	ERH	4	4	7	2	0	0	1	3	0	1	2	0	1	0	0	0	0	0	0	1	0	0	0	0	0	0	0	0	0	0	0	0	0			
	ISTD	1	0	0	0	0	0	1	0	0	0	1	0	0	0	0	0	0	0	0	0	0	0	0	0	0	0	0	0	0	0	0	0	0			
	Other	0	0	0	0	0	0	0	0	0	0	0	0	0	0	0	0	0	0	0	0	0	0	0	0	0	0	0	0	0	0	0	0	0			

Notes:

84 sites with systems have been installed since 2000, but only 72 of these sites have known geologic settings.

Data may total more than the total number of sites because some sites treated more than one type of contaminant during an application.

SEE – Steam Enhanced Extraction (Steam-based Heating)

ERH – Electrical Resistance Heating

ISTD – In Situ Thermal Desorption (Conductive Heating)

Other – Other Heating Methods (i.e., Radio-Frequency Heating or In Situ Soil Mixing combined with Heating)

Synthesis of Available Documentation

Table 2 summarizes key features of in situ thermal technology applications conducted since 2000. One might argue that applications conducted in recent years are more representative of the current state-of-the practice. For that reason, this table was prepared using only data from the 84 applications conducted since 2000. This table is formatted to flow from left to right, beginning with five “generalized conceptual scenarios.” The thought behind its structure is that practitioners interested in assessing the potential applicability of thermal technologies to their site would first choose the generalized conceptual scenario that best matches their site conditions. Then, by viewing from left to right across the table, they would be able to quickly review the experience base for each technology as applied to that generalized conceptual scenario.

The major columns found to the right of the generalized conceptual scenarios and thermal technologies include the total number and types of applications, chemicals treated, basic design parameters, basic operating parameters, and performance measures. Columns found under each of these main headings represent categories (i.e., pilot-scale vs. full-scale under “# of sites” heading) or distributions of specific numerical values, as in the case of the “Design Parameters” heading (e.g., three options for temperature in the treatment zone are presented: $<80^{\circ}\text{C}$, $80\text{--}110^{\circ}\text{C}$, and $>110^{\circ}\text{C}$). The numerical entry in each box of this table represents the number of sites matching that combination of conditions caused by the intersection of the row and column. For example, there are four applications of resistance heating in generalized conceptual scenario C with treatment areas $<10^4\text{ ft}^2$ ($\sim 1000\text{ m}^2$ or one-quarter acre). Note that the number of applications totaled in each column may not total 84 due to the fact that the information might not be available for all 84 applications. In general, there is a trend towards having less information as one moves through the columns (left to right) across Table 2.

Another larger table is found in Appendix B. It contains detailed site-specific information for all the thermal applications, not just applications since 2000. This table operates in the same fashion as the detailed summary table, by viewing from left to right across the table.

Settings in Which In Situ Thermal Technologies Have Been Applied

Table 2 shows that majority of the thermal applications were conducted in generalized scenarios B and C. Scenario B (low permeability with high permeability lenses) accounts for 43% (36 of 84) of thermal treatments, two-thirds of which are ERH applications. Of interest was that most conductive applications occur in scenario B (10 of 17), as do ERH applications (24 of 48). Scenario C (high permeability with low permeability lenses) settings account for roughly another one-third (29%) of all applications. The majority of applications in scenario C settings are ERH, although steam heating had most of its applications (6 of 15, or 40%) within this geologic setting.

Few applications in generalized scenarios A, D, and E were identified (7, 4, and 1 of 84 total documented applications, respectively). This may reflect the low frequency of

occurrence of homogeneous settings in nature (scenario A) as well as the difficulty and risks in dealing with complex fractured and bedrock settings.

Table 2 also summarizes information available on the chemicals present at 83 of 84 sites. Of those 83 sites, chlorinated solvents were treated at 63 (76%) of the sites. Petroleum hydrocarbons were the other main contaminant category treated by thermal applications and represent about 36% (30 of 84) of sites in this study. Wood-treating and other chemicals accounted for about 13% of sites (11 of 84).

Basic Design Information Summary

Table 3 summarizes aggregate design information for all applications reviewed. As can be seen, 117 of 121 applications for which data were available involved treating areas $<4 \times 10^4 \text{ ft}^2$ ($<3,716 \text{ m}^2$, or about one acre) and roughly two-thirds of those involved treatment zones smaller than 10^4 ft^2 ($<929 \text{ m}^2$, or about a quarter-acre).

Table 11. Basic design information compiled for all sites reviewed

Technology	Number of Sites With Target Treatment Zones With Sizes In This Range [ft ²]				Number of Sites With Density of Energy Delivery Points (electrodes or wells) In this Range [# per 100 ft ²]			
	<10 ⁴	10 ⁴ - 4x10 ⁴	<4x10 ⁴	Unknown	<0.25	0.25-0.50	>0.5	Unknown
Steam-Based Heating	16	6	4	20	20	2	4	20
Resistance Heating	36	24	0	27	10	23	27	27
Conductive Heating	19	6	0	1	1	1	23	1
Other (including Mixing/Heating)	8	2	0	13	2	0	8	13

* For the three steam auger sites, the density is one energy point per cell. This does not fit into the number calculation so it is classified as <0.5.

With respect to the area density of energy delivery points (i.e., steam injection wells, electrodes, and in situ heaters), there were clear differences between the technologies. Table 2 categorizes the number of energy delivery points per 100 ft² (~ per 10 m²), and indicates that most steam designs (20 of 26 with sufficient information) had densities of less than one energy delivery point per 400 ft² (~ one per 40 m², or greater than 20-ft (6-m) spacings) while most conductive heating applications involved densities greater than one energy delivery point per 200 ft² (~ one per 20 m², or less than 14-ft [4.2-m] spacings). Electrical resistance applications spanned the range of density categories but were weighted more towards higher densities and electrode spacings less than 20 ft (6 m).

Basic Operating Conditions Summary

Table 4 summarizes the basic operating conditions for all the applications reviewed. Of the 95 applications for which temperature data were available, 63 were operated at temperatures in the 80-110°C range in the target treatment zone. With respect to technology, most (37 of 46, or 80%) of the electrical resistance heating applications were operated within that 80-110°C range, while one-third (7 of 21) of the steam applications were operated at temperatures less than 80°C, and about half of the conductive heating applications were operated at temperatures greater than 110°C.

Table 12. Basic operating conditions summary for all applications reviewed

Technology	Number of Sites With Temperatures in Target Treatment Zone in These Ranges [C]				Number of Sites With Active Heating Durations in These Ranges [y]				Number of Sites With Post-Treatment Monitoring in These Ranges [y]			
	<80	80 - 110	>110	Unknown	<0.5	0.5 - 1.0	>1.0	Unknown	<0.5	0.5 - 2.0	>2.0	Unknown
Steam-Based Heating	7	13	1	25	14	0	3	29	2	0	0	44
Resistance Heating	9	37	0	41	38	2	0	47	1	5	1	80
Conductive Heating	0	11*	12*	4	18	3	0	5	1	1	0	24
Other (including Mixing/Heating)	2	2	1	18	6	0	0	17	3	0	0	20

* One site had two different temperature values. The 80-110°C temperature was for the saturated zone and the >110°C temperature for the vadose zone.

Of note in Table 4 are the durations of application. Of the applications for which data were available, 81 of 84 were operated for less than 6 months, and this pattern is true for all thermal technologies. It should be noted that there was little documentation as to the criteria or rationale used to determine the duration of operation; in many cases, it appeared that the duration was determined prior to start-up or may have been linked to some time-temperature criterion (i.e., operate for 2 months once a target temperature is reached). There was little indication that the duration of operation was linked to mass removal-, groundwater quality-, or soil concentration-based criteria.

Additionally, Table 4 provides information on post-treatment groundwater monitoring ranges. Of the 182 sites, only 14 (8%) have known information on post-treatment monitoring. One-half of the 14 sites was monitored for less than 6 months, while only one site was monitored for more than 2 years.

Post-Treatment Impact of In Situ Thermal Treatment

One of the least informative parts of this study was looking at groundwater quality improvements and contaminant mass discharge (flux) reductions as a performance measure. Of the 182 sites, there was sufficient documentation to assess groundwater improvements and source zone mass discharge reductions for only 14 applications. Two of the 14 were described as pilot treatments; however, the treatment zone appeared to completely encompass the source zone at those sites so a mass discharge analysis was performed.

Table 5 presents the estimated order-of-magnitude concentration and mass discharge percent reductions for these 14 sites. In 9 of 14 sites (64%), the dissolved groundwater concentration reduction was about one order-of-magnitude (10X) or less, and four sites had concentration reductions equal to or greater than two orders-of-magnitude (100X). Because mass discharge calculations involve spatially variable hydraulic conductivity data, the mass discharge reduction can differ from the overall concentration reduction. For example, at sites with a 10X concentration reduction or less, the estimated mass discharge reduction varied from <10X to 1000X. Nine sites had mass discharge reductions of about 10X or less and almost one-half of the sites (6 of 14, or 43%) had at least a 100X reduction in mass discharge (please note that Site #6 is counted in both the less than or equal to 10X reduction and greater than or equal to 100X because the mass discharge values were calculated for two different vertical intervals).

Table 13. Effect of application of in situ thermal technology on dissolved groundwater concentrations and mass discharge (flux) from treatment zone to the aquifer

Site No.	Heating Technology	Generalized Scenario/Site	Dissolved Groundwater Concentration Reduction	Mass Discharge Reduction				
				<10x	10x	100x	1000x	>1000x
1	ERH	Generalized Scenario A ^(SDC)	10x			x		
2	ERH	Generalized Scenario B ^{+(SDC)}	<10x	x	x			
3	ERH	Generalized Scenario C	10x		x			
4	ERH	Generalized Scenario C* ^(SDC)	>10x to <100x		x			
5	ERH	Generalized Scenario C [^]	<10x	x				
6	ERH	Generalized Scenario C [^]	<10x	x		x		
7	ERH	Generalized Scenario C	<10x				x	
8	ERH	Generalized Scenario C ^(SDC)	10x		x			
9	ERH	Generalized Scenario C ^(SDC)	100x			x		
10	ERH	Generalized Scenario C	1000x		x			
11	SEE	Generalized Scenario C	100x			x		
12	SEE	Generalized Scenario C	10x	x				
13	SEE	Generalized Scenario C [^]	10000x				x	x
14	SEE	Generalized Scenario D*	<10x	x				

* Pilot application appeared to encompass the entire source zone based on documentation reviewed.

+ Mass discharge assessment involved two calculations using first only the post-treatment field investigation data and then the post-treatment field investigation data supplemented with data from a set of monitoring wells that were directly in line with the field investigation transect.

^ Site used two different vertical intervals to calculate mass discharge: 1) Only shallow geology and 2) shallow and deep geology.

SDC – supplemental data collection site for this project

Because of the paucity of post-treatment performance data, supplemental data collection was conducted as a part of this project at the sites summarized in Table 6. At four of the sites this involved high spatial resolution post-treatment groundwater sampling and aquifer characterization along a transect immediately down-gradient of the treatment zone and perpendicular to groundwater flow. The fifth site involved the collection and analysis of groundwater samples from conventional wells before, during, and after treatment.

Table 14. Characteristics of sites where detailed post-treatment sampling was conducted

Site ID	Technology	Geology at This Site is Most Like This Conceptual Scenario ¹	Number of Permanent Monitoring Wells	Type of Chemicals Treated (C-chlorinated solvents, P-petroleum hydrocarbons, W-Wood-treating, O-other)	Size of Target Treatment Area [ft ²]	Thickness of Target Treatment Interval [ft]	Depth to Water [ft]
Hunter Army Airfield Former Pumphouse #2	ERH	A	12	P, O	30,000	8	13
Air Force Plant 4 Bldg. 181	ERH	B	21	C	21,780	37	30
NAS Alameda Building 5, Site 5-1	ERH	C	15	C	14,520	20	6
Ft. Lewis EDGY Area 3	ERH	C	17	C, P	18,200	30	N/A
Camp Lejeune Site 89	ERH	C	26	C	15,873	21	5

¹Scenario Descriptors (for the target treatment zone)

A - relatively homogeneous and permeable unconsolidated sediments (sands, etc.)

B - largely impermeable sediments with interbedded layers of higher permeable material

C - largely permeable sediments with interbedded lenses of low permeable material

D - Competent, but fractured bedrock

E - Weathered Bedrock

ERH - Electrical resistance heating

N/A – Not Available

Tables 7 and 8 summarize results from the post-treatment sampling. Details of each site and concentration contours across the sampling transects are found in Triplett Kingston (2008). Table 7 compares pre- and post-treatment concentration ranges, while Table 8 summarizes the pre- and post-treatment mass discharge estimates.

Table 15. Range of permanent monitoring well pre- and post-treatment concentration data (ug/L)

Site	Contaminant	Pre-treatment Concentration Ranges From Site Documentation (ug/L)		Post-treatment Concentration Ranges from Supplemental Field Investigations Performed Under This Study (ug/L)	
		High	Low	High	Low
Hunter Army Airfield, Former Pumphouse 2	Benzene	1,670	102	342	ND<1
	Toluene	3,630	7.6	18	ND<1
	Ethylbenzene	9,470	426	377	ND<1
	Xylenes	40,500	594	169	ND<1
	Naphthalene	N/A	N/A	43	ND<1
Air Force Plant 4, Bldg 181	Vinyl Chloride	N/A	N/A	1	ND<1
	1,1-Dichloroethene	N/A	N/A	120	ND<1
	Trans-1,2-Dichloroethene	N/A	N/A	26	ND<1
	1,1-Dichloroethane	N/A	N/A	390	ND<1
	Cis-1,2-Dichloroethene	N/A	N/A	14,000	ND<1
	1,2-Dichloroethane	N/A	N/A	670	ND<1
	1,1,1-Trichloroethane	N/A	N/A	1	ND<1
	Trichloroethylene	285,000	5,960	59,000	130
	1,1,2-Trichloroethane	N/A	N/A	ND<1	ND<1
	Tetrachloroethene	N/A	N/A	5	ND<1
NAS Alameda, Site 5-1, Bldg. 5	Vinyl Chloride	8,140	ND<0.5	29	ND<1
	1,1-Dichloroethene	15,100	ND<0.5	2	ND<1
	Trans-1,2-Dichloroethene	300	ND<0.5	2	ND<1
	1,1-Dichloroethane	48,800	15	2	ND<1
	Cis-1,2-Dichloroethene	13,700	ND<1.3	71	ND<1
	1,2-Dichloroethane	ND<250	ND<0.5	ND<1	ND<1
	1,1,1-Trichloroethane	42,000	ND<0.5	ND<1	ND<1
	Trichloroethylene	1,600	ND<0.5	76	1
	1,1,2-Trichloroethane	ND<250	ND<0.5	ND<1	ND<1
Tetrachloroethene	54	ND<0.5	47	ND<1	
Camp Lejeune, Site 89	Vinyl Chloride	1,400	ND<1	24,000	ND<1
	1,1-Dichloroethene	N/A	N/A	1,700	ND<1
	Trans-1,2-Dichloroethene	49,800	ND<2	33,000	ND<1
	Cis-1,2-Dichloroethene	224,000	ND<2	110,000	1
	Trichloroethylene	541,000	ND<2	140,000	ND<1
	1,1,2-Trichloroethane	18,600	ND<2	3,600	ND<1
	Tetrachloroethene	3,720	ND<2	1,800	ND<1
	1,1,2,2-Tetrachloroethane	2,240,000	ND<2	240,000	ND<1
Ft. Lewis EGDY** Area 3	Vinyl Chloride	5,800	ND<1	170	ND<1
	1,1-Dichloroethene	N/A	N/A	24	ND<1
	Trans-1,2-Dichloroethene	480	ND<1	38	ND<1
	Cis-1,2-Dichloroethene	30,000	ND<1	2,200	ND<1
	Trichloroethylene	17,000	2	2,200	ND<1
	Tetrachloroethene	9	ND<1	1	ND<1
	1,3,5-Trimethylbenzene	88	ND<1	19	ND<1
	1,2,4-Trimethylbenzene	22	ND<1	ND<1	ND<1

Note: * NAPL was found in a well; ND<X denotes non-detection at X ug/L detection level

**EGDY: East Gate Disposal Yard

Table 16. Summary of mass discharge calculations at field investigation sites

Site	Contaminant	Pre-treatment Discharge (kg/yr) ¹	Post-treatment Mass Discharge (kg/yr) ²	Post-treatment Mass Discharge per Linear Foot (kg/yr/ft)
Hunter Army Airfield Former Pumphouse 2*	Total Contaminant Flux	5.2x 10 ¹	1.9 x 10 ⁻¹	1.1 x 10 ⁻³
Air Force Plant 4 Bldg 181**		6.0x 10 ¹	2.1 x 10 ¹	1.4x 10 ⁻¹
			4.9	3.4x 10 ⁻²
NAS Alameda Site 5-1, Bldg. 5*		4.9 x 10 ¹	1.3 x 10 ⁻¹	9.6 x 10 ⁻⁴
Camp Lejeune Site 89*		6.8x 10 ²	8.2x 10 ¹	5.5 x 10 ⁻¹
Ft. Lewis EGDY Area 3***	3.2 x 10 ¹	2.1	1.9x 10 ⁻²	

Notes:

1 Mass discharge calculations were based on monitoring well data from the documentation.

2 Mass discharge calculations were based on discrete-depth sampling data, or a combination of discrete-depth sampling data and monitoring well data.

* Mass discharge calculations were based on discrete-depth sampling data only.

** Mass discharge calculations were performed for discrete-depth sampling data only and discrete-depth sampling data with monitoring well data.

*** Mass discharge calculations were based on monitoring well data analyzed by Arizona State University personnel.

As can be seen, the groundwater quality improvement and mass discharge reductions achieved vary from site to site, with the Naval Air Station (NAS) Alameda site showing the most beneficial impact of treatment and the Camp Lejeune site having the least. The primary reason for this difference is likely the extent to which the treatment zone encompassed the source zone. For example, the sampling results from the Camp Lejeune site showed that the dense non-aqueous phase liquid (DNAPL) source zone was much larger than the ERH treatment zone, and the Fort Lewis EGDY Area 3 site data also suggested a source up-gradient of the treatment zone. In any case, the data available to date suggest that one- to two-order of magnitude (10X to 100X) reductions in dissolved groundwater concentration and mass discharge are achievable with in situ thermal treatment systems. Worse performances will occur when source zones are poorly delineated and the treatment footprint is smaller than the extent of the source zone. Better performance might be achieved if less arbitrary operating duration criteria are used and systems are optimized and operated for longer durations.

Summary

The growing interest and application of in situ thermal remediation technologies inspired ESTCP to fund the study *Critical Evaluation of State-of-the-Art In Situ Thermal Treatment Technologies for DNAPL Source Zone Treatment (ER-0314)*. This document is one of the products of that work. It is intended to be a useful tool and primer for program managers considering the use of thermal technologies at their sites. The following might be of particular interest to this audience:

- In situ thermal technologies have undergone rapid development and application in recent years as they promise the potential of quicker and more thorough treatment of NAPL source zones. Relatively short treatment durations of a few months to a year are not uncommon and some argue that in situ thermal technology performance is less restricted by non-uniform subsurface conditions than other in situ technologies.
- Brief introductions to in situ thermal technologies with emphasis on the most widely practiced, including ERH, conductive heating/ ISTD, and SEE are included in the introduction. Of additional interest to readers might be the more in-depth discussions found in Appendix A on ERH, ISTD, SEE, and LDA soil mixing combined with steam/hot air injection. Those write-ups were authored by in situ thermal technology vendors and reflect their experiences and perspectives on the state-of-the-practice.
- In brief, the main difference between technologies is their mode of energy delivery. Ultimately, each relies on elevated temperatures to promote fluid mobility, volatilization, and/or contaminant destruction. Each will need to deliver similar amounts of energy to accomplish cleanup and each has similar aboveground treatment needs. The selection of one process over another may ultimately be determined by the temperature one needs to achieve (i.e., only ISTD can achieve temperatures greatly in excess of 100°C), factors limiting energy distribution and delivery rate (electrical conductivity, soil permeability, etc.), vendor availability, practical constraints, and economic factors. Some may assert that different processes offer competitive advantages with respect to contaminant removal in certain settings, but there are limited data available to evaluate those claims.
- Summaries of key information gained from a review of 182 thermal applications conducted from 1988 to 2007 indicate which technologies are currently being most frequently applied (ERH and ISTD) and which settings they have been applied to most frequently (chlorinated solvent source zones in layered geologic settings). Most in situ thermal treatments reviewed had footprints of less than an acre, and many had footprints of less than one-quarter acre.

- The empirical analysis of available information also suggests that design approaches are converging to the routine use of closely spaced (<20 ft) energy delivery points (electrodes for ERH or heater elements for ISTD).
- The operating duration for most in situ thermal applications seems to arguably have been arbitrary, with cessation of heating after reaching and maintaining a target temperature for some pre-defined period of time. It seems that there is an opportunity here to better define operational endpoints based on metrics more closely related to the conventional cleanup goals (i.e., target soil and groundwater cleanup concentrations).
- While it is clear that all in situ thermal remediation processes can be designed and implemented to heat soils and that this heating results in increased mass recovery via vapor and liquid extraction over ambient conditions, the longer-term effect of treatment on groundwater quality improvements and source zone mass discharge reductions is not well understood. Despite the relatively large number of applications to date, there are limited data on post-treatment monitoring. Of the 182 sites, there was sufficient documentation to assess post-treatment groundwater quality improvements and source zone mass discharge reductions for only 14 applications.
- The available data suggest that one- to two-orders of magnitude (10X to 100X) reductions in dissolved groundwater concentration and mass discharge are achievable with in situ thermal treatment systems. Worse performance occurs when source zones are poorly delineated and the treatment footprint is smaller than the extent of the source zone. Better performance might be achieved if system footprints are over-designed to extend beyond the source zone boundaries, less arbitrary operating duration criteria are used, and systems are optimized and operated for longer durations.
- Given the cost of implementing thermal technologies, investment in more confident source zone delineation prior to design and implementation is suggested, so that the treatment zone footprint can encompass the entire source zone. In this work, the sampling of groundwater along a transect immediately down-gradient of the source zone and perpendicular to groundwater flow was cost-effective for identifying the width of the source zone.

References and Suggested Reading

- Baker, R.S., and G. Heron. 2004. "In-Situ Delivery of Heat by Thermal Conduction and Steam Injection for Improved DNAPL Remediation." In: A.R. Gavaskar and A.S.C. Chen (Eds.), *Remediation of Chlorinated and Recalcitrant Compounds—2004*. Paper 2B-18 in Proceedings of the Fourth International Conference on Remediation of Chlorinated and Recalcitrant Compounds. Monterey, CA. May 24-27, 2004.
- Beyke, G., and D. Fleming. 2005. In Situ Thermal Remediation of DNAPL and LNAPL Using Electrical Resistance Heating. *Remediation*. Summer: 5-22.
- Davis, E. L. 1998. *Steam Injection for Soil and Aquifer Remediation*. Ground Water Issue No. EPA 540-S-97-505. U.S. Environmental Protection Agency: U.S. Government Printing Office: Washington, DC.
- Davis, E. L. 1997. *How heat can enhance in-situ soil and aquifer remediation: Important chemical properties and guidance on choosing the appropriate technique*. EPA 540-S-97-502. U.S. Environmental Protection Agency: U.S. Government Printing Office: Washington, DC. April 1997.
- Environmental Protection Agency. 1995. *In situ remediation technology status report: Thermal enhancements*. EPA 542-K-94-009. Office of Solid Waste and Emergency Response, Technology Innovation Office. April 1995.
- Kavanaugh, M.C., S.C. Rao, L. Abriola, J. Cherry, G. Destouni, R. Falta, D. Major, J. Mercer, C. Newell, T. Sale, S. Shoemaker, R. Siegrist, G. Teutsch, and K. Udell. 2003. The DNAPL Remediation Challenge: Is There a Case for Source Depletion? U.S. EPA 600-R-03-143. Ada, OK: National Risk Management Research Laboratory, U.S. EPA.
- Ladd, Beth, Curtis C. Travis. 1995. *In situ thermal technologies for site remediation*: By Lawrence A. Smith and Robert E. Hinchee. Battelle Memorial Institute, 209 pages.
- McGuire, T.M., J.M. McDade, and C.J. Newell. 2006. Performance of DNAPL Source Depletion Technologies at 59 Chlorinated Solvent-Impacted Sites. *Ground Water Monitoring and Remediation*, 26(1): 73-84.
- National Science Foundation (U.S.). 2005. *Contaminants in the Subsurface : Source Zone Assessment and Remediation*. Committee on Source Removal of Contaminants in the Subsurface. Washington, DC: National Academy Press.
- National Research Council (NRC).1999. *Groundwater and Soil Cleanup*. Washington, DC: National Academy Press.
- Parsons Corporation. 2005. *Cost and Performance Analysis for Thermal Enhancements at Selected Sites*. U.S. Air Force Center for Environmental Excellence..

- Price, S.L., R.S. Kasevich, M. Johnson, and M.C. Marley. 1997. Radio frequency heating for soil remediation. Paper for Proceedings of the Air and Waste Management 90th Annual Meeting and Exhibit. Toronto, Canada. June 8-13, 1997.
- Smart, J. L. 2005. Application of Six-Phase Soil Heating Technology for Groundwater Remediation. *Environmental Progress*, 24(1): 34-43.
- Stroo, H.F., M. Unger, C.H. Ward, M.C. Kavanaugh, C. Vogel, A. Leeson, J.A. Marqusee, and B.P. Smith. 2003. Chlorinated Solvent Source Zones. *Environmental Science and Technology*, 37(11): 225A-230A.
- Triplett Kingston, J.L. 2008. A Critical Evaluation of In Situ Thermal Technologies. Ph.D. Dissertation, Department of Civil and Environmental Engineering, Arizona State University.
- Udell, K. S. 1994. Thermally enhanced removal of liquid hydrocarbon contaminants from soils and ground water, Dynamic Underground Stripping Project: LLNL Gasoline Spill Demonstration Project, UCRL-ID-116964. July 1994.
- U.S. Army Corps of Engineers (USACE). 2006. "Unified Facilities Criteria (UFC): Design: In Situ Thermal Remediation". Report Prepared by U.S. Army Corps of Engineers. Publication FC 3-280-05. July 200. Available at http://costperformance.org/remediation/pdf/USACE-In_Situ_Thermal_Design.pdf.
- Vinegar, H. J., E. P. de Rouffignac, J. L. Menotti et al. 1997. Remediation of deep soil contamination using thermal vacuum wells.

Appendix A

State-of-the-Practice Technology Summaries Prepared by In Situ
Thermal Remediation Vendors

Electrical Resistance Heating
by
Greg Smith (Thermal Remediation Services, Inc.)

1.0 Overview of Technology

1.1 One paragraph description of the state of the thermal application

Electrical Resistance Heating (ERH) is an aggressive in situ thermal remediation technology that was developed by the U.S. Department of Energy from the original oil production technology to enhance vapor extraction remediation technologies in low permeability soils. Soil and groundwater are heated by the passage of electrical current through saturated and unsaturated soil between electrodes, not by conductive heating from the electrodes themselves. It is the resistance to the flow of electrical current that results in increased subsurface temperatures, and ERH is typically applied to the boiling point of the contaminant and water mixture. It is estimated that more than 75 ERH applications have been performed. Capacity to perform these projects has increased over the years, with as many as 15 to 20 of these applications now being performed at any given time, mainly in North America, with some European applications. ERH has been used to treat a wide variety of contaminants including volatile organic compounds (VOCs), chlorinated volatile organic compounds (CVOCs) (especially where light non-aqueous phase liquids (LNAPLs) or dense non-aqueous phase liquids (DNAPLs) are present), pesticides, and is now being applied to treat polycyclic aromatic hydrocarbon (PAH) compounds from manufactured gas plant sites and creosote from wood treating operations.

1.2 New improvements to the technology over the past 5 years

Technological improvements over the past 5 years have been in the area of equipment and mode of application. The modifications to the mode of application have incorporated physical, chemical, and biological processes that have been observed to occur during ERH. Improvements made to the equipment include simplification of power control units (PCUs), improvements in electrode design, and modification of water drip systems to maintain soil moisture around electrodes.

Improvements have been made to the efficiency of operations, both from an installation and energy focus, but also from an operational focus. More maintenance-friendly condensers are now being used to control costs and improve efficiency. Various electrode designs have been developed over the years for a variety of applications. Most electrode designs incorporate vapor recovery in their design. Electrodes have been constructed from steel pipe, copper plate for heating distinct zones, and sheet pile. Sheet pile electrodes allow for quick installation with little to no drilling wastes generated for disposal.

More robust, all-weather drip systems have been developed to maintain soil moisture in the vicinity of the electrodes. This allows for continuous all-weather operation in remote locations.

At the Fort Lewis, Washington, project, Thermal Remediation Services, Inc (TRS) was the prime contractor for what is believed to be the most-studied application of in situ thermal remediation to date. This work consisted of laboratory and field testing to evaluate the reductive dehalogenation mechanisms during ERH. At the time of this document preparation, much of this data is being evaluated and some additional studies are being conducted, however, some of the lessons learned from this project are being carried forward to incorporate reductive dehalogenation into the design of new applications.

Chemical processes that had not been considered for environmental remediation such as hydrolysis are now becoming the principal mechanism for cleanup for a variety of pesticides using ERH. Hydrolysis had not typically been considered a chemical process for groundwater remediation because, at typical groundwater temperatures, the reaction is too slow. At temperatures that can easily be achieved using ERH, hydrolysis reaction rates increase by several orders of magnitude. For example, methylene chloride, which has a hydrolysis half life of 3,282 years at 15 °C, has a hydrolysis half life of 35 days at 100°C.

Physical reactions that provide enhancements to fluid recovery using ERH include a process that TRS calls steam bubble floatation. This process involves the formation of gas and vapor bubbles at the non-aqueous phase liquid (NAPL)/water interface causing the NAPL to rise to the water table where it can be removed using multi-phase extraction. This process was used to recover heavy grease at Fort Lewis, Washington, and oil in Georgia.

2.0 Energy Delivery/Heating Information

2.2 Basic conceptual overview of the energy delivery/soil heating process (i.e., a conceptual drawing showing the basic components and a simple conceptual time-series of energy transfer/heating in the subsurface)

The components required to implement ERH include:

- Electrodes (steel pipe, copper plate, well points, sheet pile)
- Vapor recovery wells (which are typically co-located in the same boreholes as the electrodes)
- A steam and vapor collection system, including piping, blower, and condenser
- A vapor treatment system

- An ERH power control unit to condition power for application to the subsurface
- A computer control system with modem for data acquisition and continuous remote monitoring and control of power.

The ERH electrodes conduct electrical energy into the subsurface and can be designed to allow independent control of the energy input to discrete depth intervals. Electrodes are typically constructed using either steel pipe or copper plate to treat distinct zones in the subsurface, such that multiple electrodes can be installed within the same boring. For some applications, sheet piling has been used as electrodes. Electrodes constructed using steel pipe are installed in the subsurface in a manner similar to installing groundwater monitoring wells. In the electrically conductive intervals, the surrounding borehole annulus is packed with a conductive material, such as graphite and/or steel shot, to increase the effective (conductive) diameter of the electrode. In those portions of the subsurface where electrical resistance heating is not desired, the electrode construction materials are insulated and the surrounding annulus is filled with relatively non-electrically conductive materials such as sand or cement.

The electrodes provide the opportunity to heat discrete subsurface depth intervals. In applications having layered sequences, it may be desired to treat discrete layers separately or to create thermal barriers. ERH allows this flexibility by placing electrically conductive materials at discrete intervals within the same borehole in which the electrode is constructed. Based on the current state of the technology and experience, the practical minimum thickness of the discrete zone is 8 feet because of electrical fanning and thermal conduction.

Vapor recovery (VR) is accomplished using conventional vapor extraction techniques utilizing shallow wells installed either vertically or horizontally. Once steam and volatile contaminants have been collected by the VR system, the steam is condensed and the vapor is cooled to near ambient temperatures. Conventional vapor treatment techniques are used to adsorb or destroy the vapors. However, owing to temperatures resulting from application of ERH, the materials for the construction of the wells and headers must be able to withstand temperatures in the order of 100°C.

An ERH PCU is used to step-down standard line voltage for application as three or six separate electrical phases (as desired). The PCU includes isolation transformers that force ERH current to flow between the electrodes only, preventing ERH current from flowing to a distant electrical sink. Isolation transformers are so named because there is no conductive path between the isolated circuit and the rest of the electrical grid. Because there is no electrical path through the isolation transformer, electricity cannot leave the ERH field. Resistance by the subsurface environment to this flow of electrical current heats the soil and groundwater between the electrodes. Because electrically conductive intervals can be installed to different depth intervals, and the application of energy to the

different parts of the electrode field can be controlled, it is possible to heat separate subsurface zones either independently or in unison.

The ERH process is automated, with an onsite computer equipped with a modem and appropriate software for remote access and monitoring. Multiple applications can be monitored and controlled remotely from the remediation site or sites, connected via modem. Periodic site visits are required for inspection of the system, maintenance of mechanical equipment, monitoring, manual adjustments to the electrode configurations, and troubleshooting equipment malfunctions.

The only additive normally required for ERH is a drip source of potable water that is applied to soil immediately surrounding the operational electrodes. This water addition, normally incorporated in low permeability environments, prevents the soil adjacent to the electrodes from drying out and becoming nonconductive. Particular attention is paid to maintaining a net extraction of water from the site over the life of the project.

As the subsurface is resistively heated, contaminants are volatilized and soil moisture and groundwater are converted to steam. The production of steam during ERH operations effectively provides for the in situ steam stripping of VOC contaminants from the soil matrix. By raising subsurface temperatures above the boiling point of the mixture of targeted contaminants and groundwater, ERH significantly enhances the speed and effectiveness of physical contaminant removal. ERH provides the physical conditions that result in the chemical, physical, and biological reactions for their removal from the subsurface.

The rate of steam formation during ERH is very slow, typically requiring approximately 2 to 8 weeks to reach the boiling point, depending on site conditions. Once boiling does begin, it is a very gentle process, comparable to the rate of bubble formation in a glass of carbonated beverage.

The process of in situ steam generation converts groundwater to steam and then vapor recovery removes the steam from the subsurface. This has the same effect as groundwater pumping, with the net result being a slight drawdown of the water table and some measure of hydraulic control. Within the vadose zone, some decrease of soil moisture may occur if the site is covered (preventing rainfall percolation).

2.2.1 In Situ and Above-ground Treatment.

During heating, pore water increases in volume 1700-fold as it is converted to steam. This process results in the creation of fissures in clayey and silty soils, facilitating vapor transport. The steam forms very slowly, so that the formation of fissures is on a very small scale.

Above ground treatment typically involves treating vapors, condensate, and entrained water. Vapor treatment involves reducing the moisture content, typically through

conventional “knock-out” pot arrangements and heat exchangers, followed by appropriate treatment (e.g., granular activated carbon, combustion, thermal oxidation, etc.) prior to permitted atmospheric discharge. Treatment of condensate and entrained water involves liquid phase granular activated carbon and/or air stripping through a cooling tower. The cooling tower is analogous to an air stripper, with the vapor fed to the vapor stream treatment equipment. The condensate and entrained water makes multiple passes through the cooling tower, significantly reducing concentrations of volatile constituents. The treated water is then disposed of as appropriate for the site (e.g., returned to the subsurface as drip water, offsite treatment and disposal, discharge to the local publicly owned treatment works (POTW), National Pollutant Discharge Elimination System (NPDES)-permitted discharge, etc.).

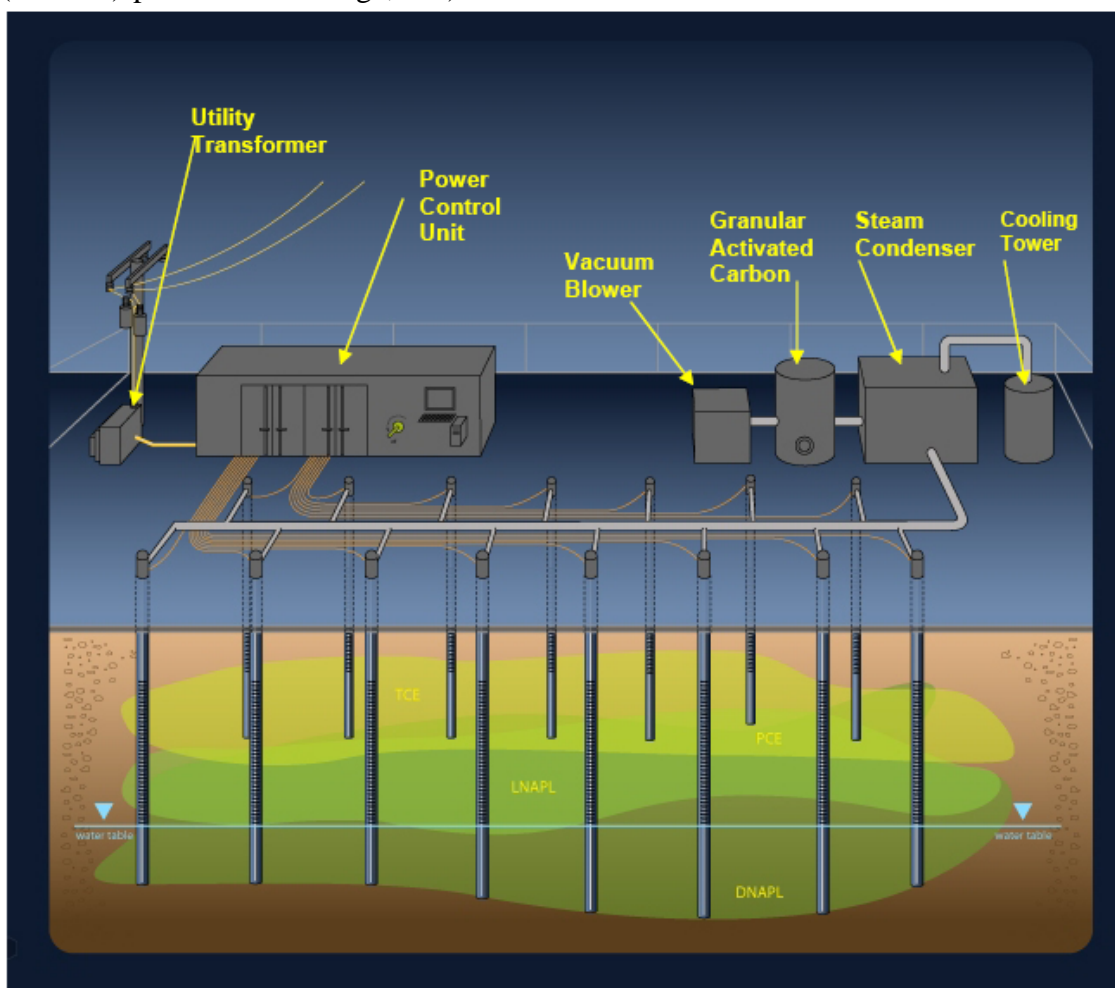

Figure 1. Conceptual depiction of the application of ERH

2.2 Any available information on relationship or current understanding between energy delivery and heating rates (i.e., efficiency of energy conversion to heat)

The relationship between energy input and temperature is not straightforward, for there are many factors that influence temperature, including the shape of the volume of the soil and groundwater that is being heated, heat losses (that are influenced by the geometry of the treatment volume), groundwater flow rate, applied vacuum and airflow rates, soil and groundwater electrical conductance, (which changes with temperature), depth of treatment beneath the water table, and other operational issues. Other operational issues relating to the rate of heating deal with the electrical conductivity of the site, the available electrical power, size and type of the vapor treatment system, and the rate at which vapors may be discharged from the treatment system.

Figure 2 presents a graph showing the applied power and resultant average temperature for a confidential site in the Chicago, Illinois, area. For this site, power was initially applied at a relatively high level but was reduced prior to the temperature achieving its maximum of 87.5°C on October 25, 2006. It should be noted that the maximum average temperature achieved was adequate and appropriate for this application and achieved the cleanup goals within the projected time frame.

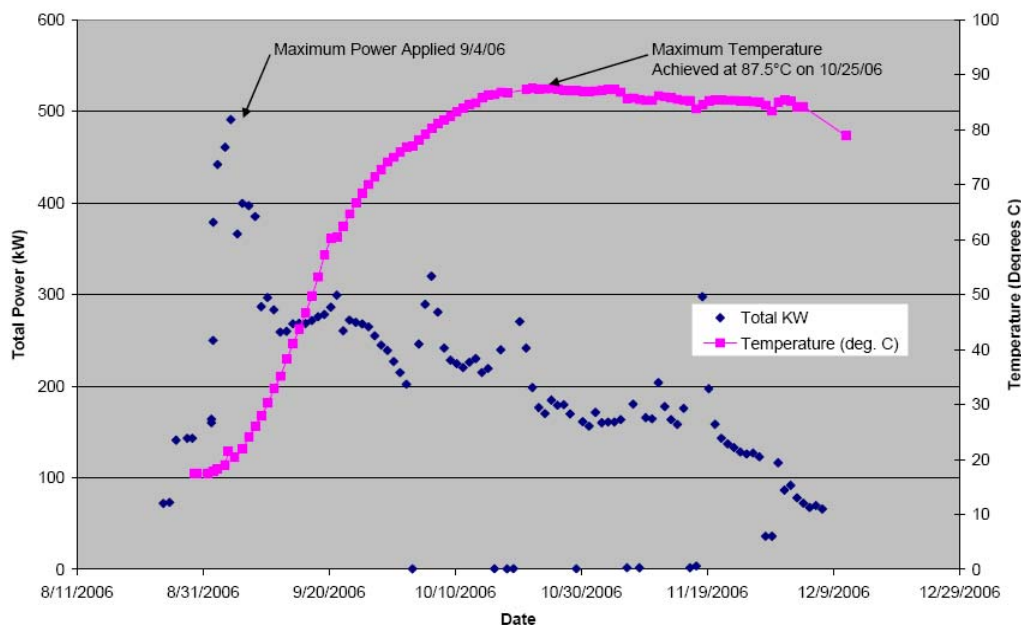

Figure 2. Applied power (kW) and temperature

2.3 Limitations of the energy delivery/heating process (i.e., what temperatures can be reached?, how even is the heat/energy distribution?, do natural phenomena limit the heating?)

The maximum temperature achievable is the boiling point of water, which is governed by the atmospheric pressure (i.e., the boiling point increases with depth). Heating increases the total dissolved solids in groundwater, which in turn increases electrical conductivity.

The total dissolved solids in groundwater are affected by biogeochemical reactions. For example, zones that may have high chloride from intrinsic biodegradation of chlorinated ethenes heat up rapidly. Heating becomes more even with time, as illustrated in Figure 3.

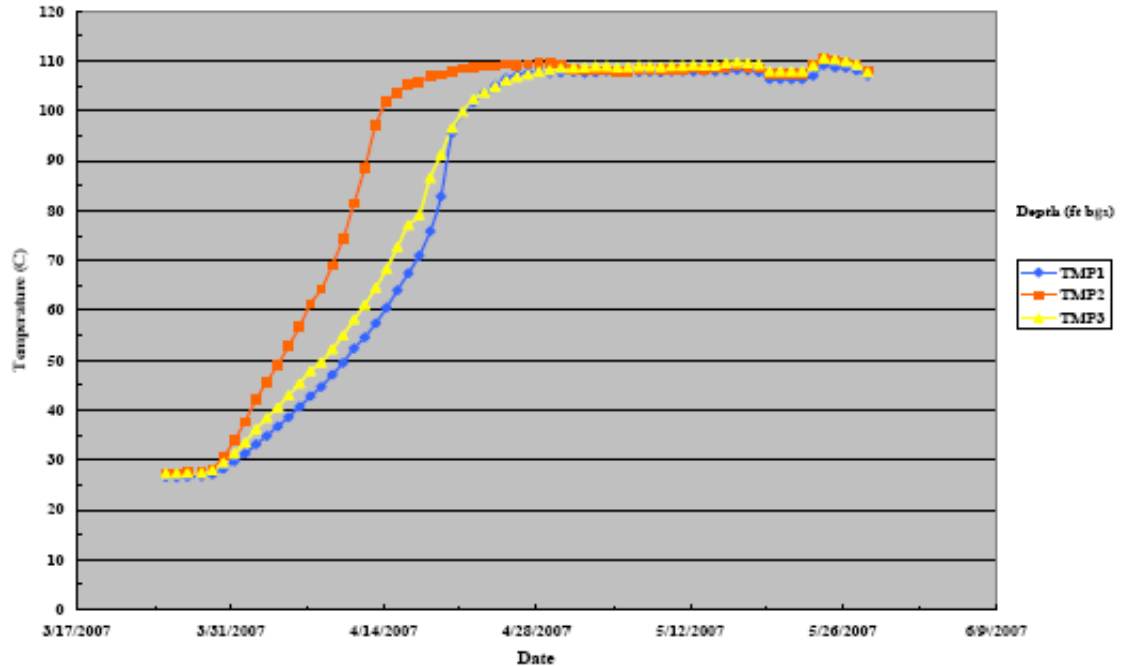

Figure 3. Temperature monitoring showing average temperature versus time at the three monitoring locations

2.4 Unique advantages/disadvantages of this energy delivery/heating approach for contaminant removal or destruction?

Because ERH involves the electrical resistance of the soil matrix to create increases in temperature, there are several inherent features that create advantages for this technology. First, it seeks out the most conductive areas for treatment first. Electrical current, seeking out the path of least resistance will heat areas of high total dissolved solids (TDS) first. Areas of high TDS are the result of biogeochemical reactions associated with the biodegradation of organic compounds, which also corresponds to areas adjacent to high contaminant concentrations. TDS increases throughout ERH, such that electrical conductivity increases as well. TRS' own testing has shown that for chlorinated ethenes and ethanes, chloride represents on the order of 90% of the anions and 40% of all major ions in water during ERH. While different zones heat up quicker, the site is typically heated to a uniform temperature at depth as illustrated in Figure 3, providing for complete treatment throughout.

Second, the technology is self correcting. If some areas heat up in preference to others, the moisture content is reduced, in turn reducing the ability of the soil and groundwater to

conduct electricity. The electrical current will seek other pathways until the previously heated area is re-hydrated either naturally or from the ERH drip system.

The electrodes, as noted above, are constructed of readily available materials (steel pipe, copper plate, sheet pile, etc.) using standard drilling techniques, and multiple electrodes can be constructed within the same borehole to heat selective zones. The deepest heating has been to 100 ft in Paducah, Kentucky.

2.5 Is the process applied differently if the contaminants are below the water table?

There is no real difference between applications above and below the water table. The technology requires a minimum of 3% field moisture. The main concern with applications below the water table is groundwater velocity of greater than 1 ft/day, which results in heat losses that need to be controlled. Control can be performed through conventional groundwater control methods (i.e., wells, French drains, sheet pile, slurry walls, freeze walls, etc.).

3.0 Process Configuration Information

3.1 Generic layout of the process showing spacing (heaters, electrodes, wells, temperature, etc.) of in situ components for a "typical" application

Figure 1 presents the conceptual layout for an ERH application. Electrodes are spaced 15 to 23 ft (4.6 to 7 m) apart. The spacing is dependent upon the characteristics of the contaminants to be treated, the desired rate of heating, expected heat losses, the construction of the electrodes that can be achieved, and the desired final temperature to be achieved.

Temperature monitoring points are located throughout the treatment area and are typically located equidistant between groups of electrodes to monitor temperatures at the furthest distance from the energy application point. Each temperature monitoring point consists of a string of thermocouples, typically set at 5 ft depths.

3.2 Generic layout of above-ground components, showing the footprint of a "typical" application

The layout of the above ground treatment components is dependent upon space available and access. In general, the vapor recovery blower and the condenser are located in a manner to minimize piping from the treatment area, but maintain a safe distance from the area that is being treated. Granular activated carbon vessels and a Baker tank for temporary water storage are typically located in a manner to provide for vehicular access for water removal (if required) and change out of carbon (if required).

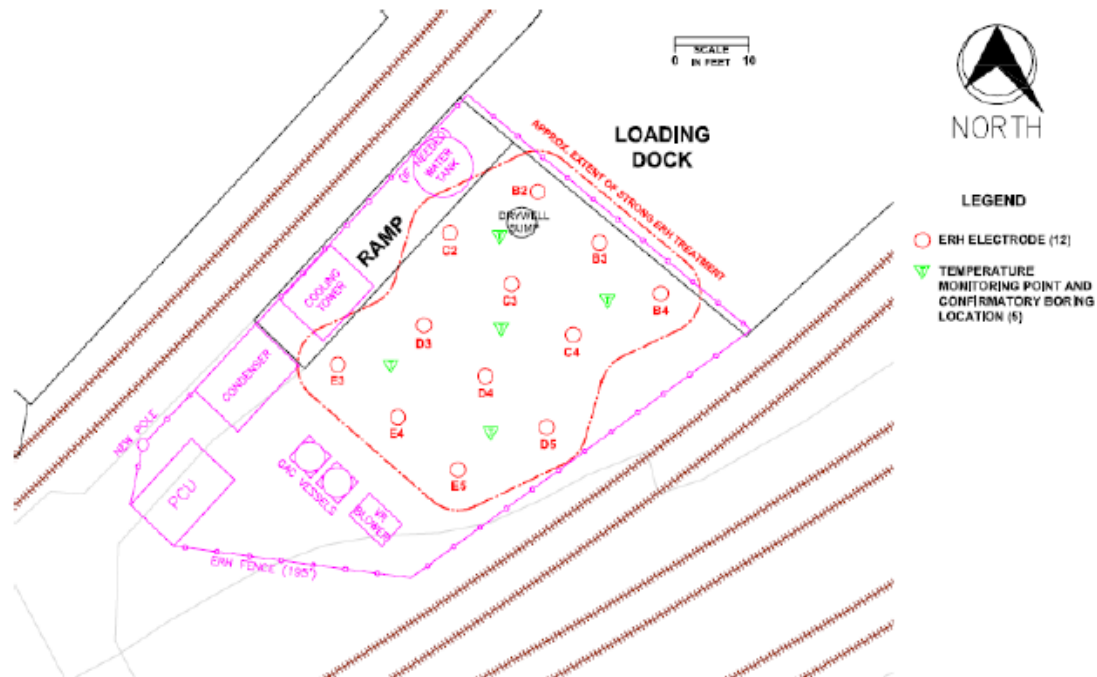

Figure 4: Typical equipment layout for ERH application

3.3 Special utility requirements (power, water, surface cover, security, etc.)

Depending on the equipment needed for a given site, 480 V three-phase or standard 13.8 KV three-phase line voltages are required to power the PCU, which then distributes power to the electrodes and ancillary equipment. A source of potable water is also required during the initial phases of application as a source of drip water and for the cooling tower at start up. Water during operations is normally supplied by the condensate produced from the heating. A data quality telephone line may be necessary for adequate remote communications. Surface covers typically consist of existing pavement or concrete if working in an industrial area. For bare ground applications, the surface may be covered with polyethylene sheeting, depending on depth of treatment below grade. The sheeting is used to maintain vacuum and minimize the surface infiltration from precipitation.

The level of security depends on where the ERH treatment is being performed. Historically, most locations have involved working in or around active and shuttered factories, where standard chain-link fencing and placarding indicating the electrical hazards has been appropriate. The next level of security that is typically used involves perimeter electronic monitoring to provide alarmed automatic shut down of the system to prevent potential electrical shock to intruders. When the perimeter system is tripped, the operator is notified and the system is restarted once the operator has confirmed that operations can safely continue. TRS has not had to impose a higher level of security, but

if needed, this is envisaged as involving a perimeter electronic system with periodic to continuous manual security checks provided by a contract security company.

3.4 Is the process configured differently if the contaminants are below the water table?

As noted in Section 2.5, there is no real difference between applications above and below the water table and as such there is no difference in the configuration.

4.0 Process Information

4.1 Typical monitoring/diagnostics for the technology during operation (i.e., how do you know it's working?)

Monitoring during ERH involves tracking temperature, power and energy application, and organic vapor concentrations. It has been observed that most of the organic vapors are produced during the heat-up portion of operations. When organic vapor concentrations decrease by approximately 80% from peak concentrations, electrical resistance heating typically is temporarily stopped and interim groundwater or soil sampling is performed. The analytical results are then evaluated to determine if and where additional treatment is required. Power application to individual electrodes may be ceased in order to focus treatment in select areas, thus reducing cost. Natural attenuation processes (most importantly intrinsic biodegradation) are also commonly assessed at this time to determine if remediation goals can be attained under post-thermal treatment conditions. Based upon the results of interim sampling, heating can be continued or post-remedial sampling can be conducted to document that the remedial action objectives for soil and groundwater have been met.

4.2 Post-treatment issues (time period needed for cooling/access/etc.)

After ERH treatment, soil and groundwater typically return to ambient temperatures within 6 to 24 months. During this cool down period, groundwater and soil sampling may be safely conducted using the proper precautions. TRS has developed protocols for sampling that have been approved by federal and state environmental protection agencies. Safe access to the site is normally restored within two days to two weeks of cessation of power application.

5.0 Technology Selection

5.1 For what scenarios is the technology ideally suited?

ERH has been most widely applied for the remediation of chlorinated ethenes and ethanes where DNAPL is present, since these groups of chemicals represent the most commonly encountered environmental contaminants, with the exception of fuels. There

have been a small number of sites contaminated with fuels that have been remediated using ERH. ERH has also been used to hydrolyze a few pesticide impacted sites and is now seeing some application for manufactured gas plant (MGP) site and creosote sites.

5.2 Under what conditions is the technology "challenged"?

As noted above, the technology may be challenged in instances where heat losses through high groundwater flow may represent an issue. These conditions can usually be mitigated using engineered solutions.

ERH has been used in buildings where there has been sufficient overhead clearance from which to install the electrodes. This is generally site-specific, depending upon the overhead clearance and available drilling equipment with which to install the electrodes. Electrodes drilled at an angle have been successfully installed and used at a number of sites to access difficult areas.

Some PAH compounds may represent a challenge. Generally, significant reduction in concentration (>85%) has been observed for compounds with boiling points of less than 300°C. PAH compounds, with boiling temperatures of greater than 300°C tend to adhere to the soils and are not significantly reduced, but are not considered mobile in groundwater environments.

Concerns over geotechnical stability are dealt with relatively easily and have not represented a problem. ERH does not pose a threat to underground foundations and utilities.

Thermal Conduction Heating
by
Gorm Heron and Ralph Baker (TerraTherm)
10 Stevens Road
Fitchburg, MA 01420

1. Overview of Technology

1.1 One paragraph description of the state of the thermal application

In situ thermal desorption (ISTD) is the simultaneous application of heat by thermal conduction heating (TCH) and vacuum to remediate organic source zones. The technology has been applied at full scale to remediate a wide variety of contaminants, ranging from low-boiling VOCs and CVOCs to high-boiling PAHs, polychlorinated biphenyls (PCBs) and dioxins. It has been applied to treat both vadose and saturated zone sites, as well as fractured media (clay and rock). Virtually every project achieves much lower post-treatment concentrations than the goals. Treatment costs have been lowered dramatically by technology simplifications.

1.2 New improvements to the technology over the past 5 years

Over the past five years, ISTD has undergone a number of technology improvements. The heater wells have become simpler, less expensive, and more able to resist corrosive conditions. They are amenable to installation by most available drilling methods, with installation rates in the range of 200–400 ft per day per rig. Control systems have become simplified. Off-gas treatment can be accomplished by a wider array of components, with the choice depending on project requirements. ISTD has been performed over a wide range of thermal well spacings and time durations, and the energy requirements for a range of subsurface conditions are well understood. As treatment costs have decreased, more CVOC DNAPL sites have been treated, where initially ISTD was mostly used for PCB soil decontamination.

2. Energy Delivery/Heating Information

2.1 Basic conceptual overview of the energy delivery/soil heating process (i.e., a conceptual drawing showing the basic components and a simple conceptual time-series of energy transfer/heating in the subsurface)

Figure 1 shows a generic sketch of a small ISTD site.

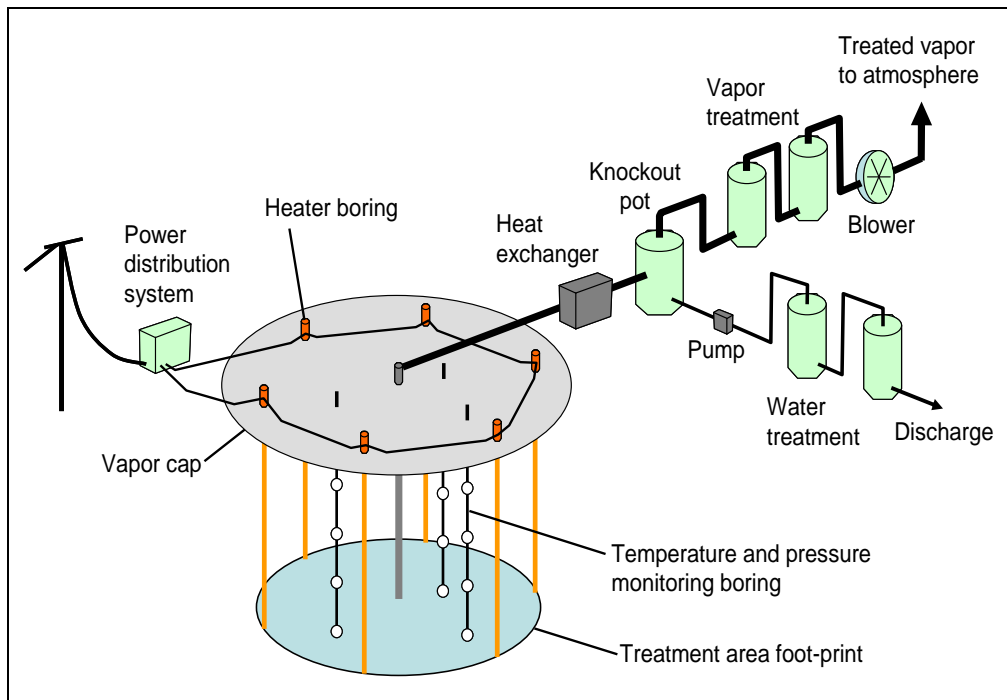

Figure 1. Conceptual sketch of in situ thermal desorption system

A typical site has the following components:

- Transformer to supply 480 V, 3-phase power
- Simple electrical distribution switchgear and controllers for the heaters
- Cables to all ISTD heater borings
- Vertically installed heater borings, with a simple resistive heater element hanging inside a 3-in diameter steel casing, either driven in or installed with grout and sandpack
- Vapor recovery wells (horizontal or vertical, or both, depending on geology)
- Where necessary for hydraulic control, groundwater extraction wells or a physical hydraulic barrier
- Temperature and pressure monitoring wells
- An off-gas and water treatment system with varying components depending on contaminants and expected mass loading.

Energy transfer is by thermal conduction and fluid convection around the heaters, as the heater borings are heated to temperatures above 500°C. More detail is provided in LaChance et al.².

² LaChance, J., G. Heron and R. Baker. 2006. "Verification of an Improved Approach for Implementing In-Situ Thermal Desorption for the Remediation of Chlorinated Solvents." *Remediation of Chlorinated and Recalcitrant Compounds: Proceedings of the Fifth International Conference* (May 22-25, 2006). Battelle, Columbus, OH.

A typical operational period, using treatment to the boiling point of water as an example, is provided in Figure 2.

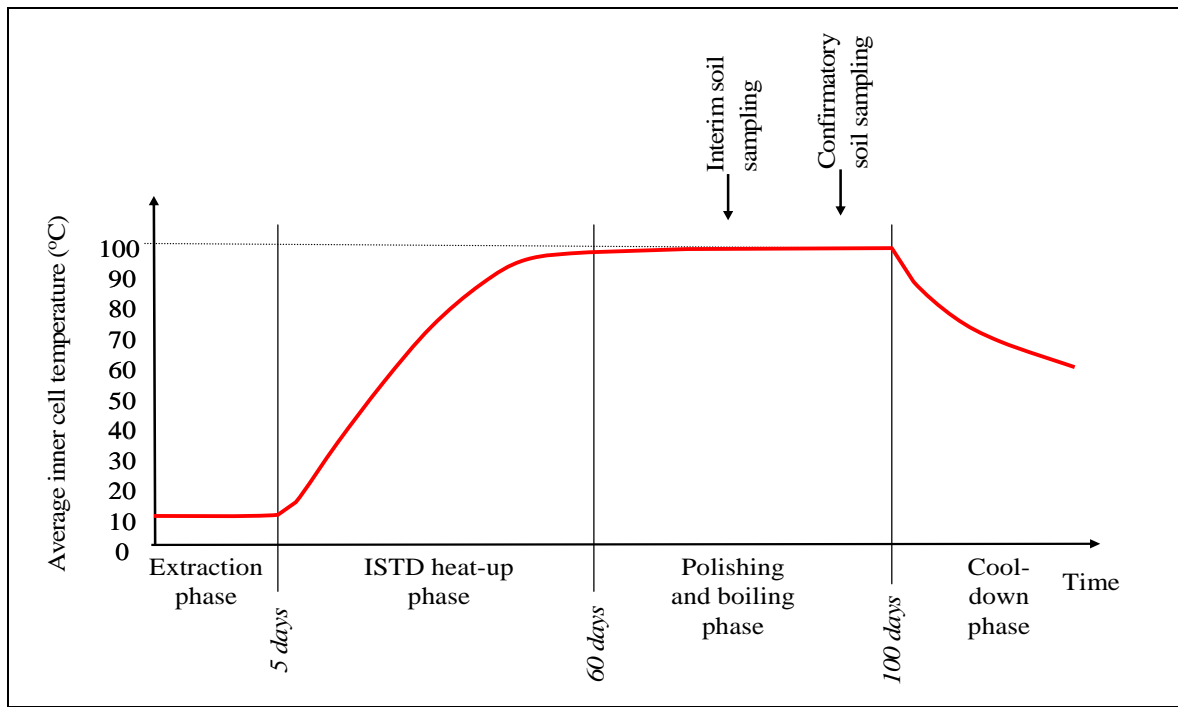

Figure 2. Typical timeline for operation of an ISTD system for VOC remediation

The extraction phase is used to document pneumatic control and to demonstrate that the off-gas treatment system meets the regulatory demands for contaminant removal efficiency. If groundwater is extracted, this period is also used to document hydraulic control and sufficient water treatment.

During the heat-up phase, ISTD power is injected into each heater at rates of approximately 300-350 W per linear ft of heater, and the ground heats up due to the temperature gradients created and convection of heated fluids such as steam, air, and water.

The polishing phase is primarily a phase where steam is generated in situ, and steam stripping is used to lower contaminant concentrations to below target levels. It often overlaps with heating of the bottommost depths, and/or areas that lag behind the average heating, to the target temperature.

Interim and final confirmatory soil sampling (and groundwater sampling, where required) is used to assess the treatment efficacy. Once the data comes back from the laboratory and shows that the objectives are met, a short cool-down period follows, where steam is removed from the subsurface and the site is cooled to an acceptable final temperature. Then, the ISTD equipment and the well-field are decommissioned.

2.2 Any available information on relationship or current understanding between energy delivery and heating rates (i.e., efficiency of energy conversion to heat)

To avoid overheating of wells and heater materials, the heater element power input is limited to below 400 W/ft of heater. For instance, a 30-ft long heater will only be able to supply on the order of 10-12 kW of energy to the subsurface. This energy is conducted away from the heaters and partially used to vaporize groundwater into steam.

The efficiency of converting electric power to heat is around 99% or better—basically all the energy is deposited in the heater elements, with minor losses in switchgear and cables. Since the heating mechanism is based on the ohmic resistance of the heater rods, which are fully imbedded in the treatment volume, this is a direct and highly efficient way of heating.

Heat losses come from conduction of heat to the surface, perimeter, and bottom, where ISTD heaters typically extend between 2 and 5 ft outside the target treatment zone to ensure heating of the entire volume to the target temperature. These heat losses are inevitable and part of any heating technology where sufficient care is taken to treat the edges of the target volume.

The heating rate is typically calculated for the coolest locations within the target treatment zone, and is directly dependent on the spacing between neighboring heaters (located in a triangular pattern). Typical durations are shown in Table 1.

Table 1. Typical duration of ISTD operation as a function of heater spacing

Heater boring spacing (ft)	Operational duration for CVOC source zones (days)
10	60-80
12	90-120
15	120-180
20	300-400

Actual durations are site-specific and depend on factors such as:

- Initial saturation (the wetter the longer it takes)
- Porosity (the higher the longer it takes)
- Water table position
- Groundwater seepage velocity and recharge (if a hydraulic barrier is not used)
- Mineral composition (minor differences between common minerals)
- Initial contaminant mass
- Target contaminant concentration (the lower the longer it takes).

If the project schedule is critical, the heater spacing is chosen for a given site to match the available time. This is typically done for Brownfield sites such as the Richmond site³, where a property transfer and/or construction of new homes drive the schedule.

2.3 Limitations of the energy delivery/heating process (i.e., what temperatures can be reached?, how even is the heat/energy distribution?, do natural phenomena limit the heating?)

For compounds with boiling points below 150°C, steam stripping and vaporization are effective mechanisms, and the boiling point of water is used as the target treatment temperature.

For sites where dewatering is undesirable or not practical, the presence of water will buffer the temperature to the steam temperature, which is 100°C above the water table and increases with depth and pressure below the water table. At 33 ft depth below water, where the pressure is 2 atm (14.6 psig or 29.2 pounds per square inch absolute [psia]), the steam temperature is 120°C.

For semi-volatile organic compounds (SVOCs) such as PCB, coal tar, PAH and creosote, higher temperatures are used as the target treatment temperature. The target temperatures are in the range of 200°C to 350°C, depending on the physical and chemical properties of the limiting contaminant. Heating to these temperatures involves removing or boiling all of the soil moisture, which enables heating the dry soil/sediment above steam temperatures. Due to the high treatment efficiency (including accelerated kinetics of oxidation and pyrolysis⁴) at temperatures below 325°C, sites are rarely heated beyond this temperature.

³ LaChance et al. 2006. Ibid.

⁴ Baker, R.S. and M. Kuhlman. "A Description of the Mechanisms of In-Situ Thermal Destruction (ISTD) Reactions." In: H. Al-Ekabi (Ed.), *Current Practices in Oxidation and Reduction Technologies for Soil and Groundwater*. Presented at the 2nd International Conf. on Oxidation and Reduction Technologies for Soil and Groundwater, ORTs-2, Toronto, Ontario, Canada, Nov. 17-21, 2002.

The most critical factors controlling the ability to heat a site to the target temperatures are:

- *Groundwater flow, which can lead to cooling where water enters the treatment volume.* Each design must address the potential for groundwater influx and cooling. In certain clay formations, permeable fractures can lead to rapid groundwater flow and cooling, as observed at a site in Ohio⁵. Other sites with groundwater zones with significant flow rates may be addressed either by limiting the flow using pumping or barriers, or by combining ISTD with the injection of steam to heat the more permeable zones⁶.
- *Air inflow due to the applied vacuum, leading to cooling.* This is typically very minor due to the low heat capacity of atmospheric air, and the modest flow rates.
- *Target zone geometry.* (Very shallow sites and irregularly shaped sites take longer due to large surface areas and heat losses; deep sites and equidimensional sites heat faster due to low heat losses).

Each thermal design involves a careful review of the geometry, specifically the hydrogeology and potential impacts of water flow on the heating regime. Where needed, a detailed 3-D numerical simulation is used to evaluate impacts and worst-case scenarios.

2.4 Unique advantages/disadvantages of this energy delivery/heating approach for contaminant removal or destruction?

Heating depends primarily on thermal conduction—therefore the “sweep” is highly uniform. Clay layers, sand zones, and gravel zones heat up at very similar rates due to small variations in thermal conductivity (varying by a factor of only approximately three from sand to clay) and heat capacity of various minerals, sediments, soils, and rocks. This is the primary advantage of ISTD—that our heating pattern and therefore treatment duration is highly predictable. This allows the treatment performance (as determined by reduction in contaminant concentrations) to be highly predictable as well.

A unique advantage is that the ISTD heaters are simple steel rods that can be as long and deep as the site requires. The same heaters are used in the oil field for heating zones with

⁵ LaChance, J.C., R.S. Baker, J.P. Galligan, and J.M. Bierschenk. 2004b. “Application of ‘Thermal Conductive Heating/In-Situ Thermal Desorption (ISTD)’ to the Remediation of Chlorinated Volatile Organic Compounds in Saturated and Unsaturated Settings.” Paper 2B-21, in: A.R. Gavaskar and A.S.C. Chen (Eds.), *Remediation of Chlorinated and Recalcitrant Compounds—2004*. Proceedings of the Fourth International Conference on Remediation of Chlorinated and Recalcitrant Compounds (Monterey, CA; May 2004). ISBN 1-57477-145-0, published by Battelle Press, Columbus, OH, www.battelle.org/bookstore.

⁶ Baker, R.S. and G. Heron. 2004. “In-Situ Delivery of Heat by Thermal Conduction and Steam Injection for Improved DNAPL Remediation.” Paper 2B-18, in: A.R. Gavaskar and A.S.C. Chen (Eds.), *Remediation of Chlorinated and Recalcitrant Compounds—2004*. Proceedings of the Fourth International Conference on Remediation of Chlorinated and Recalcitrant Compounds (Monterey, CA; May 2004). ISBN 1-57477-145-0, published by Battelle Press, Columbus, OH, www.battelle.org/bookstore

thicknesses over 500 ft. The heaters are in 3-inch simple casings, and the borehole size does not increase as the heaters need to go deeper. Since the power used to generate heat in each heater flows through the entire length of the heater, it puts out the same power density along the length of the heater, leading to relatively uniform heating over the length of the heater, despite differences in the sediment/soil/rock properties with depth. This can allow for uniform heating of deep sites with simple surface controls. One example of this, with ISTD heating to 110 ft, is the recent project in Alhambra, CA⁷.

A potential disadvantage is the ability to heat a zone with groundwater flow carrying the heat away or cooling by entry of cold water. As discussed above, such cooling has to be either limited by means of a barrier (hydraulic or physical), overcome by injecting steam into the highly conductive zones, or overcome by adding more ISTD heaters to increase the power density in such zones. A good and detailed analysis of the site hydrogeology is key to managing this potential disadvantage.

For SVOCs, heating to temperatures above boiling can lead to significant in situ destruction of contaminants. This may reduce the mass loading on the off-gas treatment system. Mechanisms and reaction processes are described by Baker and Kuhlman⁸.

2.5 Is the process applied differently if the contaminants are below the water table?

In principle, no. The ISTD heaters are installed and operated in the same manner. But the hydrogeology issues and potential for groundwater flow discussed above become important. In addition, vapor extraction and control becomes dominated by steam generation and capture, as the heat creates steam. An analysis and example of this for a site where ISTD was used to treat CVOCs 15 ft below the water table is discussed by LaChance et al.⁹

As the heat travels horizontally away from the heater borings, vapors are generated by in situ boiling of groundwater (and NAPL, if present). The generated vapors travel towards the heaters, and upward along the heater borings where increased gas phase permeability is created by the drying in the immediate vicinity of each heater. The vapors are captured and extracted by vapor collectors located in the vadose zone. This continuous removal of VOC mass, starting a few hours after the onset of heating, is a key mechanism for removal of VOCs from below the water table.

⁷ Bierschenk, J.M., R.S. Baker, R.J. Bukowski, K. Parker, R. Young, J. King, T. Landler, and D. Sheppard. 2004. "Full-Scale Phase 1a Results of ISTD Remediation at Former Alhambra, California Wood Treatment Site." Paper 4A-09, in: A.R. Gavaskar and A.S.C. Chen (Eds.), *Remediation of Chlorinated and Recalcitrant Compounds—2004*. Proceedings of the Fourth International Conference on Remediation of Chlorinated and Recalcitrant Compounds (Monterey, CA; May 2004). ISBN 1-57477-145-0, published by Battelle Press, Columbus, OH, www.battelle.org/bookstore.

⁸ Baker and Kuhlman, Ibid.

⁹ LaChance et al 2006. Ibid.

For SVOCs below the water table, water presence can prevent heating to above the boiling point. Therefore, a site-specific analysis of possible treatment efficacy with and without dewatering is performed. The cleanup standard typically drives this, as complete contaminant removal to very low soil concentrations will require dewatering and heating to above boiling, and less aggressive treatment goals such a removal of all VOC components and stabilization of the leftover NAPL phase allows treatment at the boiling point¹⁰.

3. Process Configuration Information

3.1 Generic lay-out of the process showing spacings (heaters, electrodes, wells, etc.) of in situ components for a "typical" application

Heaters are typically located in a triangular pattern as shown on Figure 3.

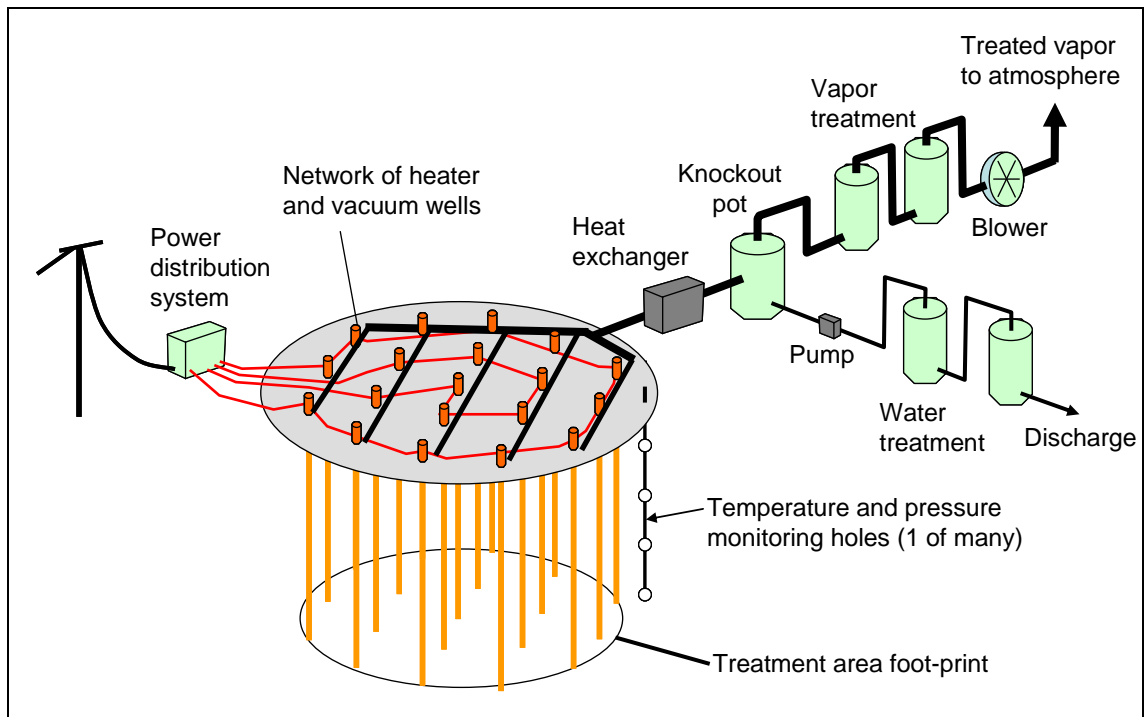

Figure 3. Generic layout of heater borings and process equipment for an ISTD project

¹⁰ Baker, R.S., D. Brogan and M. Lotti. 2006. "Demonstration of Tailored Levels of In-Situ Heating for Remediation of a Former MGP Site." Proceedings of the International Symposium and Exhibition on the Redevelopment of Manufactured Gas Plant Sites (MGP2006), Reading, England, April 4-6, 2006. *Journal of Land Contamination and Reclamation*, 14(2):335-339.

The spacing between heater borings is discussed in Section 1.2. For VOC sites, the heater spacing typically varies between 12 and 20 ft. For SVOC sites heated to above boiling, a typical heater spacing is between 6 and 12 ft.

Vapor and water extraction wells can either be vertical wells within the pattern (heated or unheated) or horizontal or angled wells located in optimized positions to capture the heated fluids. Figure 4 illustrates a cross-sectional view of a site where steam vapors are extracted near each heater (which is used for sites with high NAPL saturations to minimize condensation during heating) and a number of horizontal vapor extraction wells located in the vadose zone.

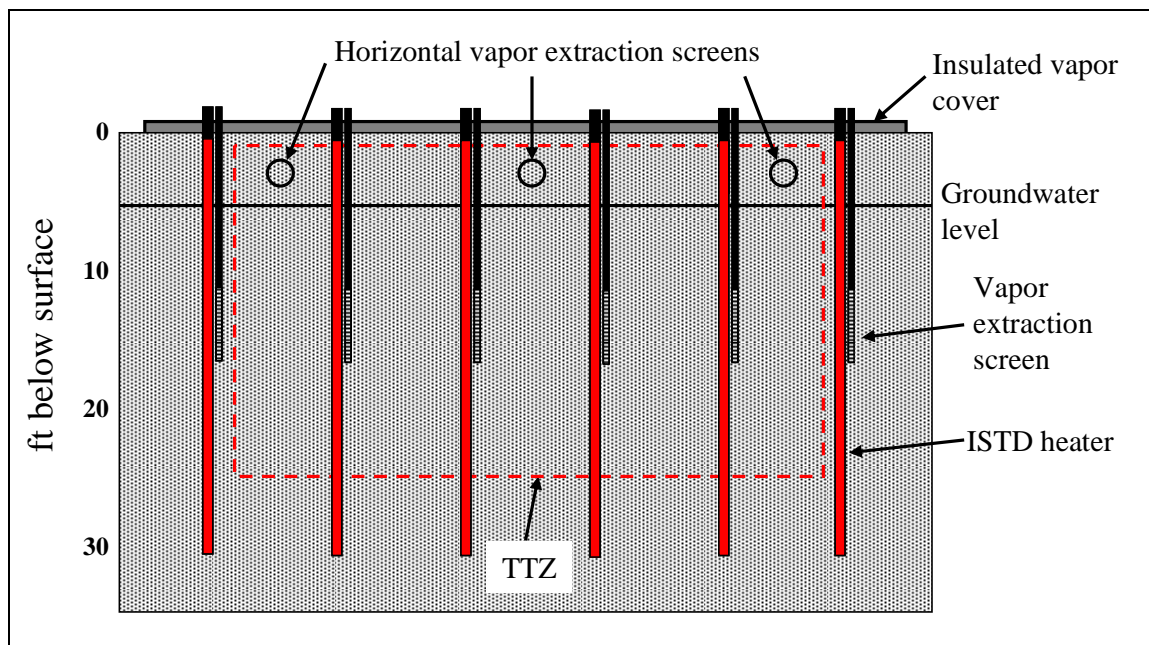

Figure 4. Conceptual cross-section of an ISTD treatment zone

Each site is analyzed in detail, and the vapor and water recovery wells and extraction approach is determined based on site-specific conditions.

A vapor cover is typically used when treating to shallow depths. The cover serves three purposes:

1. It provides thermal insulation and prevents contaminants from condensing near the land surface, which will occur if the soil is cool.
2. It prevents rainwater infiltration, which could lead to unwanted cooling of the treatment zone.
3. It provides a vapor seal and increases the radius of influence of the vapor extraction screens.

Temperature and pressure monitoring wells are simple vertical borings used to document performance and pneumatic control during treatment. These are located inside and outside the treatment area, typically at different distances from the heaters to illustrate the heating progression.

3.2 Generic lay-out of above-ground components, showing the footprint of a "typical" application

The above-ground equipment varies from site to site depending on treatment area size, volume, nature of contamination, and local regulatory requirements for treating the effluents. A typical simple system is shown in Figure 5.

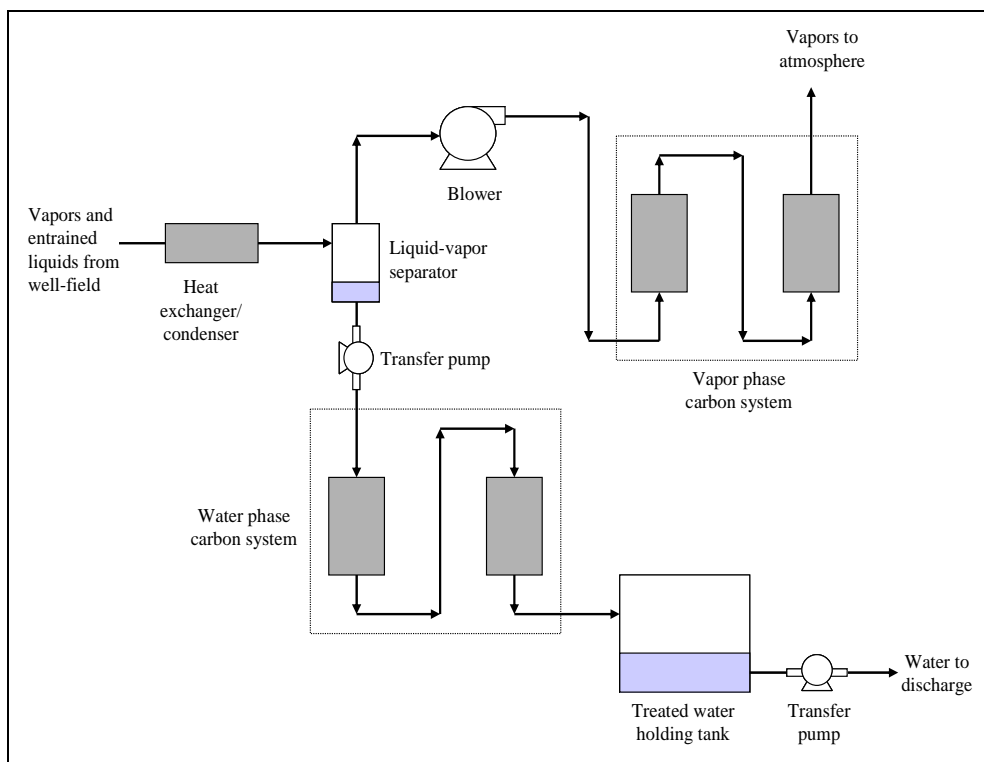

Figure 5. Example treatment system for fluids recovered during ISTD implementation

For sites with large contaminant mass loading, the vapor treatment is often done using thermal oxidation or other methods capable of handling the high recovery rates.

The surface layout is dictated by site-specific conditions such as the location of utility connections, obstructions such as buildings, and an effort to minimize the piping runs from the well field area to the treatment process. For small sites, the treatment system is placed on a trailer or in a container and mobilized to the site as one unit. For sites requiring large treatment components, individual process equipment units may be mobilized and connected at the site.

3.3 Special utility requirements (power, water, surface cover, security, etc.)

The required utilities are:

- Power (480 V, 3-phase)
- Water (for drilling, cleaning, office trailer, and sometimes for the process if using a cooling tower or wet acid gas scrubbing)
- Gas or diesel when fuel is used for either off-gas treatment (such as an oxidizer) or for generating power as a back-up
- Telephone and Internet for communications and process controls.

3.4 Is the process configured differently if the contaminants are below the water table?

This depends on whether dewatering is necessary, as discussed in Section 1.5. Often, treatment below the water table involves groundwater extraction and treatment.

4. Process Information

4.1 Typical durations of applications, and how does one decide to turn it off?

For VOC sites, typical durations are between 2 months and 1 year, depending on site-specific requirements and the chosen heater spacing (Section 1.2).

For SVOC sites, typical durations are between 6 months and 1 year.

Performance is typically based on soil concentrations since soil can be readily sampled during operation using methods identical or similar to those tested and documented by Gaberell et al.¹¹ The criteria for turning off the system are typically the same as the criteria for successful remediation—the system is operated until the client has regulatory approval that the remedy is complete.

Sampling of soil eliminates a classical problem—groundwater rebound occurring after the treatment. By sampling the phase from where rebound would originate (by desorption and diffusion out of bypassed solids), the risk of post-remediation contaminant concentration increases is minimized or eliminated.

¹¹ Gaberell, M., A. Gavaskar, E. Drescher, J. Sminchak, L. Cumming, W-S. Yoon, and S. De Silva. 2002. Soil Core Characterization Strategy at DNAPL Sites Subjected to Strong Thermal or Chemical Remediation. Paper 1E-07, in: A.R. Gavaskar and A.S.C. Chen (Eds.), *Remediation of Chlorinated and Recalcitrant Compounds—2002*.

For some sites without specific numeric cleanup standards, other parameters are used to determine when to cease operation:

- *Groundwater concentrations* (although these are hard to use due to the complex chemistry at elevated temperatures and the difficulty in collecting representative samples without loss of the contaminants). Groundwater samples can potentially show more impressive remediation results due to the low solubility of most VOCs in hot water. Basing the decision to stop treatment on such samples may be risky—and rebound could occur during cool-down.
- *Target treatment temperature*. This would be applied to the coolest locations within the target treatment zone and used to focus the heating process towards the end of the operational period. Laboratory treatability tests can be used as guidance for selection of the target temperature and thereby provide an indication of remedial completeness when the target temperature is reached.
- *Energy balance calculation showing steam stripping and generation of a certain amount of steam* (typically related to the pore volume of the treatment zone). The amount of steam generation/stripping needed can be estimated based on laboratory testing and depends on initial concentrations and the specific remediation goals.
- *Diminishing recovery of contaminants while ensuring that the heating process and fluid extraction process are operated according to specifications*. This can be risky since diminishing returns can be reached without treatment of the entire targeted volume, as documented as an interim result at the Young-Rainey STAR project¹², where the discovery of a cool area led to focused heating and more complete remediation after the vapor recovery had dropped to low levels temporarily.

Site-specific performance goals are negotiated and typically made part of the contract for the ISTD project. They typically tie directly into the regulatory demands for site closure or remedy acceptance, such that the client and the ISTD contractor work towards the same objective.

4.2 Typical monitoring/diagnostics for the technology during operation (i.e., how do you know it's working?)

The monitoring is based on:

- Hydraulic control (documented using groundwater elevation monitoring).
- Pneumatic control (documented using pressure monitoring).

¹² Heron, G., S. Carroll, and S.G.D. Nielsen. 2005. Full-Scale Removal of DNAPL Constituents using steam enhanced extraction and electrical resistance heating. *Ground Water Monitoring and Remediation*, 25(4): 92-107.

- Subsurface temperatures (documented using thermocouples). This includes thermocouples located in a subset of the heater borings, used for the thermostat control of the heater elements.
- Contaminant removal rates and totals (estimated by sampling the effluent vapor, water, and NAPL). The totals are compared to initial mass estimates, considering the typical uncertainties of such estimates. However, the total mass recovered is never used to determine when to cease operation, due to the uncertainties in initial mass estimates.
- Vapor treatment efficacy (based on vapor samples before and after the treatment unit).
- Water/condensate treatment efficacy (based on water samples before and after the treatment unit).
- Interim sampling of soil and/or groundwater within and around the treatment zone (showing reductions in contaminant concentrations compared to original levels). These samples are typically the most important for determining when to cease operation.
- Final confirmatory sampling.

In addition, site-specific monitoring related to health and safety and community monitoring may be conducted.

4.3 Post-treatment issues (time period needed for cooling/access/etc.)

This is site-specific and depends on future site use. Typically, live steam is removed from the subsurface over a period of 1 to 2 weeks while the site starts the cool-down. At some sites, cold water is injected to assist with cooling. When demobilization begins, the subsurface temperatures may be as high as 90°C. Removal of the surface cover enhances the cooling. Demobilization is typically complete between 1 and 2 months after completing the remediation.

5. Technology Selection

5.1 For what scenarios is the technology ideally suited?

Generally, ISTD is favored by the following conditions:

- Recalcitrant contaminants not easily addressed by monitored natural attenuation (MNA), soil vapor extraction (SVE), or pump and treat. The most suited contaminants would include most CVOCs, DNAPL, creosote, coal tar, and PCBs.
- Large contaminant mass and concentrations, with significant NAPL presence (so less aggressive, cheaper methods are ineffective).
- Stringent cleanup standards. ISTD treats to very low final concentrations, largely independent of the starting mass and concentration.

- Sites with a driver to clean within a relatively short time frame (where long-term solutions suffer due to insecurity about when they can be shut off).
- Sites with target volumes above 3,000 cubic yards (the unit cost is higher for small sites).
- Sites deeper than 10 ft (our simple heaters can readily be extended deeper without much additional cost).
- SVOC sites where excavation is unpractical or expensive (so we can compete on a unit cost basis).

Most sites treated using ISTD have been CVOC DNAPL sites or SVOC sites with PCBs, coal tar, or creosote.

ISTD is potentially ideally suited for fractured rock sites. All known bedrock types have sufficient thermal conductivity to allow for effective heating using ISTD. The combination of very predictable heating and a high density of wells/borings for extraction, such that all or the majority of the fractures can be contacted and used for extraction of the generated steam, makes this a very promising option.

5.2 Under what conditions is the technology "challenged"?

The following conditions challenge the applicability of ISTD:

- Very shallow and wide-spread contamination. For such sites, heat losses may become prohibitive due to the large surface area. The on-site version of ISTD, termed in-pile thermal desorption (IPTD), may apply to some of these sites.
- Contamination present under structures where vertical drilling is prohibited. Heating can readily be done using angled or horizontal borings, but the complexity and cost of the drilling and installation increases significantly compared to vertical installations.
- SVOCs below the water table with stringent cleanup standards and difficulty of dewatering. If the water prohibits drying and heating to above steam temperatures, complete treatment for SVOCs to low levels may not be possible.
- Sites with high groundwater flow rates and difficulty of controlling it during operation. As described in Section 1.2, management of the groundwater flux or additional heating of the high-flow zones may be used to overcome this challenge.

Typical concerns about geotechnical stability and damage to foundations, buildings, or underground utilities are dealt with relatively easily on a site-specific basis and have not been a significant barrier to ISTD implementation.

Steam-Enhanced Extraction
by
Gorm Heron and Gregory Crisp (TerraTherm)

1. Overview of Technology

1.1 One paragraph description of the state of the thermal application

Steam-Enhanced Extraction (SEE) has been used successfully for treatment of large sites, and numerous pilot tests have shown great promise for applications to a variety of contaminants, including chlorinated solvents, oil, and creosote. Two large sites have been closed, achieving maximum contaminant level (MCL)-level groundwater concentrations after effective source removal.

1.2 New improvements to the technology over the past 5 years

The technology was significantly expanded and adapted during the period of 1998-2003 with focus on optimizing steam delivery and heating completeness, use of pressure cycling to enhance removal, and applications in moderately permeable strata and fractured rock. New combinations with thermal conduction heating are promising adaptations for heterogeneous sites, and are currently being implemented.

2. Energy Delivery/Heating Information

2.1 Basic conceptual overview of the energy delivery/soil heating process (i.e., a conceptual drawing showing the basic components and a simple conceptual time-series of energy transfer/heating in the subsurface)

SEE involves installation of a network of injection and extraction wells, installation of temperature monitoring equipment, injection of steam into the wells, and extraction of hot fluids for on-site separation and treatment¹³. Steam sweeps from the outside in and pushes NAPL and vaporized contaminants of concern (COCs) toward the central parts of the site for extraction.

The steam displaces subsurface fluids such as water, NAPL, and air and creates a steam zone with reduced liquid saturations. During the steam front propagation, the target zone is heated both by the steam itself and by the warm/hot condensate migrating in advance of it. The condensate is formed at the leading edge and boundaries of the steam zone where some of the steam condenses.

A steam zone is created between the injection and extraction wells, after the target zone for steam injection has been heated. A period of pressure cycling is then induced by varying the injection pressure and rates, as well as the applied vacuum.

¹³ Davis, E.L. (1998): *Steam injection for soil and aquifer remediation*. US EPA Issue paper EPA/540/S-97/505.

Steam Enhanced Extraction (Heron and Crisp)

Figure 1 shows a generic sketch of an SEE site.

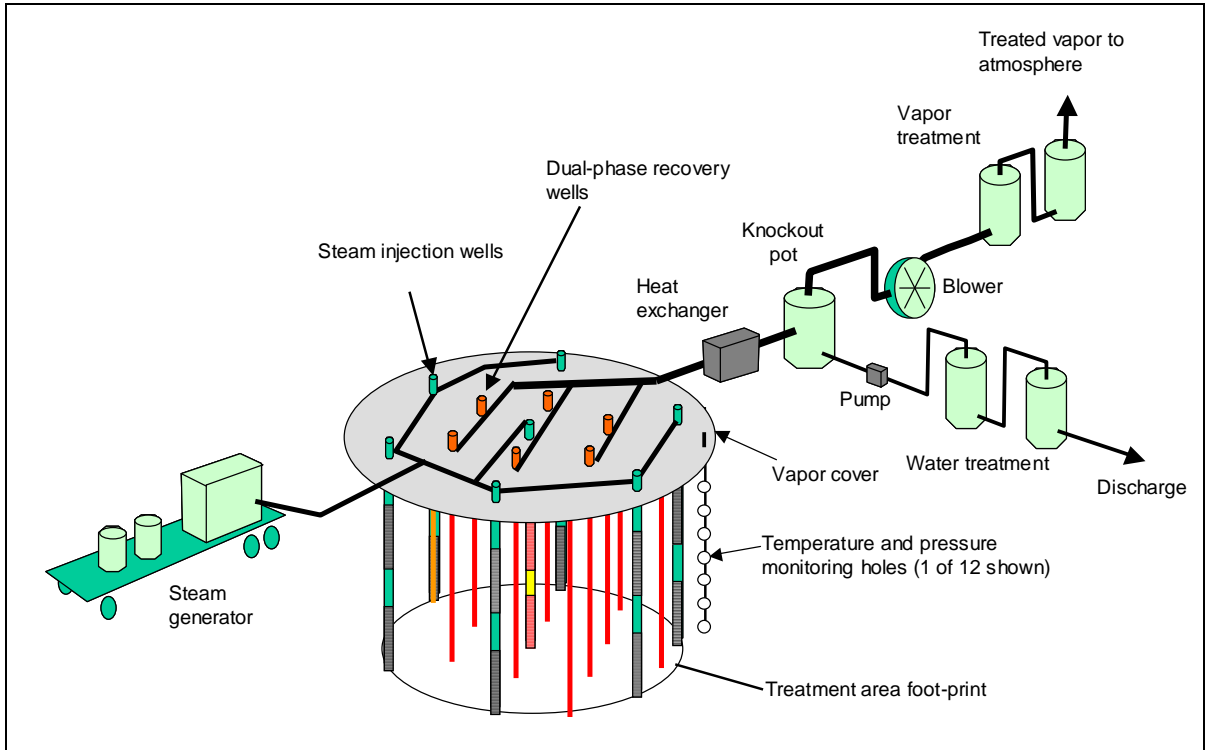

Figure 1. Conceptual sketch of steam-enhanced extraction system

A more detailed sketch of a steam generating process is shown on Figure 2. Note that the water supply is fresh water, and that the fuel can be either natural gas, propane, or diesel. Some steam generators or boilers have a pre-heating step (de-aerator), where the feed water is heated using some of the produced steam.

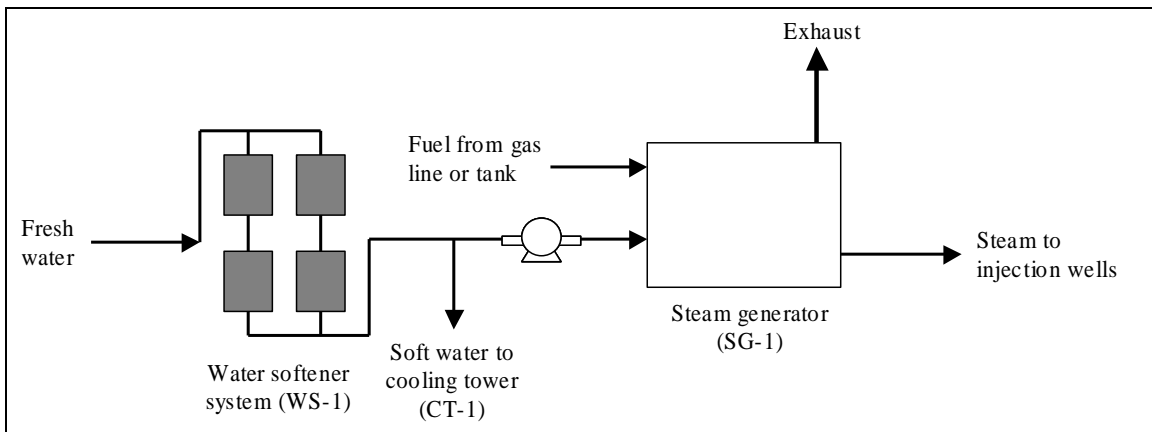

Figure 2. Steam generation system schematic

Steam Enhanced Extraction (Heron and Crisp)

For treatment of a NAPL source area, the treatment zone is typically surrounded by steam injection wells installed in clean material. The extraction wells are located in high-concentration areas, each surrounded by four or six steam injection wells.

A typical site has the following components:

- Transformer to supply 480 V, 3-phase power
- Vertically installed injection wells installed with grout and sandpack
- Groundwater and vapor recovery wells (horizontal or vertical, or both, depending on geology)
- Temperature and pressure monitoring wells.
- A water softening and steam generation system
- An air compressor or blower to deliver air for co-injection with steam (if used)
- An off-gas and water treatment system with varying components depending on contaminants and expected mass loading.

Air co-injection is sometimes used to minimize the risk of forming condensation banks containing NAPL and to enhance the vapor transport to extraction wells¹⁴.

A typical operational sequence, using treatment to the boiling point of water as an example, is provided in Figure 3.

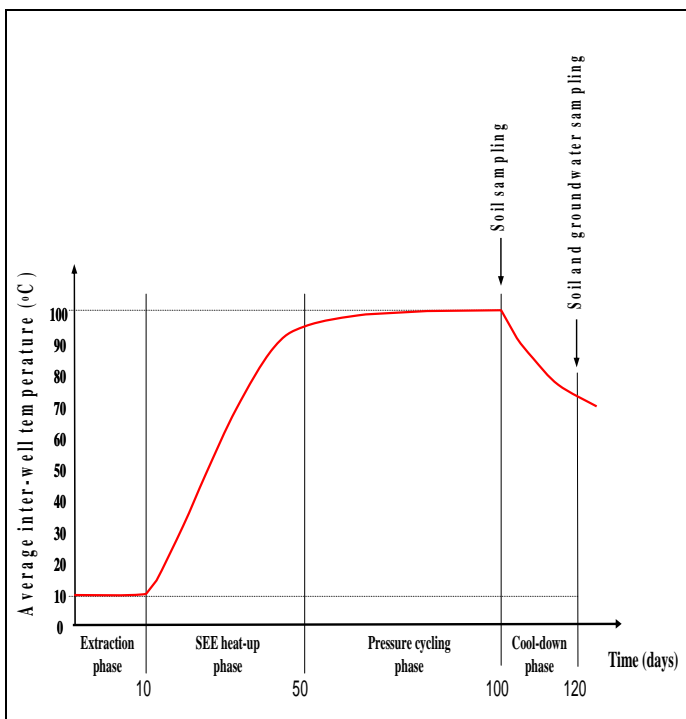

Figure 3. Typical timeline for operation of an SEE system

¹⁴ Kaslusky, S.F., and K.S. Udell, 2002. A theoretical model of air and steam co-injection to prevent the downward migration of DNAPLs during Steam-Enhanced Extraction. *Journal of Contaminant Hydrology*, 55: 213-232.

The extraction phase is used to document pneumatic control and to demonstrate that the effluent treatment system meets the regulatory demands for contaminant removal efficiency. This period is also used to document hydraulic control and sufficient water treatment.

During the heat-up phase, steam is injected into each well at a pre-determined rate (based on target zone thickness, permeability, and well spacing), and the ground heats up due to the convection of heated fluids such as steam, air, and water. The goal of this phase is to heat the target volume to steam temperature and to allow for steam breakthrough to the extraction wells. During this period, cool groundwater is being displaced to extraction wells, and a steam zone develops until steam sweeps through to the extraction wells. This period is also called the “steam sweep.”

The pressure cycling phase is a period where steam is generated in situ, and steam stripping is used to lower contaminant concentrations to below target levels. It often overlaps with heating of the bottommost depths, and/or areas that lag behind the average heating, to the target temperature. Details of the pressure cycling principle were published by Udell (1996)¹⁵. Heron et al. (2003) used pressure cycling to achieve MCL-level groundwater concentrations at the Young-Rainey STAR Center Area A site¹⁶.

Interim and final confirmatory soil sampling (and groundwater sampling, where required) are used to assess the treatment efficacy. Once the data comes back from the laboratory and shows that the objectives are met, steam injection ceases, but extraction continues until cool-down temperature targets are achieved. Then, the SEE equipment and the well-field are decommissioned.

2.2 Any available information on relationship or current understanding between energy delivery and heating rates (i.e., efficiency of energy conversion to heat)

The duration of the operational part of an SEE project can be estimated as follows:

$$\text{Duration} = \text{Heat-up period} + \text{Pressure cycling period} + \text{Cool-down period}$$

The heating period consists of aggressive steam injection and groundwater and vapor extraction. During this period, steam zones are created, and the displaced fluids are extracted, such that pneumatic and hydraulic control is maintained. Flow properties of the subsurface and injection pressures control the rate of steam injection at each site. Typically, the steam is pushed through the formation for steam breakthrough to extraction wells in less than 60 days. This is desirable to (1) limit the operations time at the site and (2) minimize the risk of steam over-ride, where the buoyancy of the steam makes it flow on top of groundwater and/or NAPL, reducing the sweep efficiency. For

¹⁵ Udell, K.S. 1996. Heat and mass transfer in clean-up of underground toxic wastes. In Annual Reviews of Heat Transfer, Vol. 7, Chang-Lin Tien, Ed.; Begell House, Inc.: New York, Wallingford, UK, pp. 333-405.

¹⁶ Heron, G., S. Carroll, and S.G.D. Nielsen. 2005. Full-Scale Removal of DNAPL Constituents using steam enhanced extraction and electrical resistance heating. Ground Water Monitoring and Remediation, 25(4): 92-107.

Steam Enhanced Extraction (Heron and Crisp)

larger sites, the steam sweep may be staged across the site, and economics of scale favor larger well spacing, such that the operational period is longer than that of each segment being heated with steam. This means that large sites have longer durations.

The following pressure cycle duration depends on the volatility of the COCs, the permeability of the formation, and the remediation goals. Less volatile COCs and more stringent goals mean longer pressure cycling. Typically, between 1 month (for small VOC sites) to a year or longer (for large creosote sites) are used. Itamura and Udell (1995)¹⁷ established guidelines for relating well spacing, soil permeability, and duration of each pressure cycle. Tighter soils require longer time for pressures to equilibrate, so at such sites the cycling takes longer.

For some sites, the number of pressure cycles, and the total amount of steam passed through the site (expressed as pore volumes of steam flushed through) can be estimated based on laboratory treatability testing. Such detailed tests involve an elaborate testing system, detailed monitoring, and careful conduct of the test to simulate field conditions as closely as possible (few if any commercial laboratories have done this successfully). Typical outcome from testing is that CVOC sites require less than 1 pore volume of steam expressed as condensate, equivalent to pressure cycling for less than 1 month (example: Alameda Point; trichloroethene (TCE)), and creosote and coal tar sites require more than 3 pore volumes, equivalent to more than a year of steam pressure cycling (example: Visalia Pole Yard). Some contaminants such as benz(a)pyrene remain in the soil after more than 10 pore volumes—it is then concluded that SEE may not be an effective method for removal of this contaminant.

Finally, the cool-down period depends on site size and objectives, but typically last between 1 week and several months. Typically, cool-down involved the removal of all steam from the formation, but not cooling much below 90°C. Then, the site cools on its own by heat conduction away from the treated volume and by groundwater flow.

Typical total durations are shown in Table 1.

¹⁷ Itamura, M.T, K.S. Udell. 1995. An analysis of optimal cycling time and ultimate chlorinated hydrocarbon removal from heterogeneous media using cyclic steam injection. Proceedings of the ASME Heat Transfer and Fluids Engineering Divisions, ASME, HTD-Vol. 321/FED-Vol. 233.

Table 1. Typical duration of SEE operation as a function of well spacing

Steam injection well spacing (ft)	Operational duration for source zones (days)	Example site
<20	50-100	Alameda Point Site 5 ¹⁸
20-40	100-200	Young-Rainey STAR Center Area A ¹⁹
>40	200-400+	Visalia Pole Yard (Creosote) ²⁰

Actual durations are site-specific and depend on factors such as:

- Initial saturation (the wetter, the longer it takes)
- Porosity (the higher, the longer it takes)
- Water table position
- Groundwater seepage velocity and recharge (if a hydraulic barrier is not used)
- Mineral composition (minor differences between common minerals)
- Initial contaminant mass
- Target contaminant concentration (the lower, the longer it takes)
- Target contaminant boiling point and volatility (higher boiling point compounds require longer operation).

If the project schedule is critical, the well spacing is chosen for a given site to match the available time.

Several tools exist for predicting/estimating the steam zone progression and time for the steam to migrate to the extraction wells. These range from simple rule-of-thumb relations (such as setting the maximum injection pressure as 0.5 pounds per square inch gauge [psig] per ft of distance above the screen) to sophisticated 3-dimensional non-isothermal simulators such as T2VOC, TOUGH2, and STARS (simulating practical steam injection rates, steam zone shapes, groundwater behavior around the steam zones, and geochemical processes that may affect the COC behavior).

2.3 Limitations of the energy delivery/heating process (i.e., what temperatures can be reached?, how even is the heat/energy distribution?, do natural phenomena limit the heating?)

Soil permeability and lithology limit applicability of SEE. Some sites are too tight to allow steam to be injected and heat the target volume sufficiently. It is typically not considered safe to inject at steam pressure above 0.5 psig per ft of overburden located over the injection screen. Higher pressures can lead to fracturing of the formation and surface escape of steam. Example sites where insufficient steam injection rates are

¹⁸ Udell et al. 2000. BERC (2000). Steam Enhanced Extraction Demonstration at Site 5, Alameda Point. Field Feasibility Demonstration for the US Navy, DO-9. Berkeley Environmental Restoration Center, University of California at Berkeley. Berkeley, CA. Final report.

¹⁹ Heron et al. 2005. Ibid.

²⁰ Eaker, Craig. 2007. Southern California Edison, Rosemead, CA. Personal communication.

Steam Enhanced Extraction (Heron and Crisp)

achievable are ones dominated by thick clay zones and competent bedrock sites with minimal fracturing. Each site must be carefully evaluated to determine whether SEE technology is the right choice for delivering the energy to the target volume.

For compounds with boiling points above 200°C, steam stripping and vaporization are not effective mechanisms, and technologies that can reach higher temperatures may be more applicable. SEE may only be capable of removing the mobile NAPL and removing more volatile components of the NAPL (lowest molecular weight compounds in the mix).

In SVOCs such as polycyclic aromatic hydrocarbon (PAH) and creosote, SEE has been shown to be effective in long-term applications such as the Visalia Pole Yard²¹, where SEE was followed by a period of enhanced natural attenuation. Field data from other sites also indicate that SEE can remove the bulk of the DNAPL mass in a relatively short period, if the subsurface hydrogeology allows for steam sweep of the DNAPL zones. However, such sites typically are not completely depleted in the organic contaminants, since steam stripping is less effective for the higher molecular weight contaminants such as benz(a)pyrene.

2.4 Unique advantages/disadvantages of this energy delivery/heating approach for contaminant removal or destruction?

Steam is by far the cheapest form of energy for injection. Typical boiler efficiencies in the range of 80 to 90% mean that ~ 85% of the fuel value in the fuel is injected. For comparison, the electricity used in ERH and TCH/ISTD applications is generated at power plants with much lower energy conversion efficiency, plus there are line losses for delivery. In addition, cold water is displaced by the advancing steam, such that it does not require energy for heating. The result is that the same block of earth can be heated using approximately half the fossil fuel of an electrical heating process. For large sites the savings may be the difference between a project being over or under the acceptable budget.

Steam injection and extraction wells are very simple and inexpensive to construct. Injection wells are 1, 2, or 4-inch diameter carbon steel pipes with a stainless steel screen, set in sandpacks and sealed using high-temperature grout. The borehole size does not increase as the wells need to go deeper.

A potential disadvantage is the inability to heat tight zones, where the steam cannot be injected at a sufficient rate. Another potential disadvantage is the steam buoyancy in deep or thick formations, where steam rise may lead to bypassing of DNAPL layers pooled at the base of an aquifer. A detailed analysis of the site hydrogeology and source zone location are key to managing these potential disadvantages.

²¹ Eaker 2007. Ibid.

Steam Enhanced Extraction (Heron and Crisp)

Relatively new heating combinations are designed to minimize the disadvantages of steam (by combining it with TCH) and optimizing the use of the lower-energy heating method (by enhancing electrical heating projects using steam injection).

2.5 Is the process applied differently if the contaminants are below the water table?

In principle, no. The steam wells are installed and operated in the same manner. However, for vadose zone applications, recovery of the condensate generated when steam cools in the formation is essential. This condensate can be rich in contaminants, particularly early on in the operational period. Thus, hydraulic control must be ensured.

Below the water table, the steam behavior is well-described from decades of enhanced oil recovery.

Most SEE sites to date have treated both a saturated zone and a vadose zone simultaneously. This utilizes hydraulic control by pumping, and pneumatic control by vacuum extraction above the water table.

3. Process Configuration Information

3.1 Generic lay-out of the process showing spacings (heaters, electrodes, wells, etc.) of in situ components for a "typical" application

Steam injection and extraction wells are typically located either in a square pattern (5-spot) or in a triangular pattern (7-spot) as shown on Figure 4. However, the pattern does not have to be regular, since this is a fluid-delivery based process without electrical phasing considerations.

Steam Enhanced Extraction (Heron and Crisp)

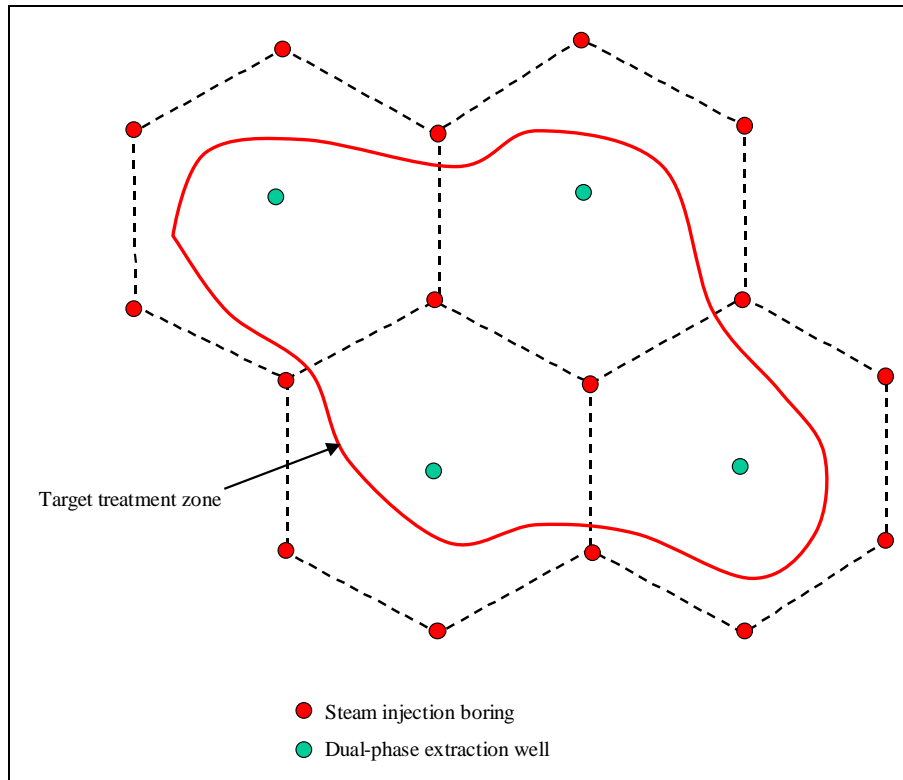

Figure 4. Generic layout of heater borings and process equipment for an SEE project

The spacing between steam wells is discussed in Section 1.2. Well spacings have ranged from 20 ft at relatively low-permeability sites to more than 50 ft at sites with high hydraulic conductivity and significant depth.

Vapor and water extraction wells can either be vertical wells within the pattern (heated or unheated), or horizontal or angled wells located in optimized positions to capture the heated fluids. Figure 5 shows the wells in a schematic cross-section. The extraction wells are fully screened, allowing for NAPL and water recovery also when the operations lead to partial dewatering and large changes in the depth of the water table. Steam injection wells are typically screened at the base of the treatment zone, or slightly deeper to account for steam rise into the target treatment zone.

Note that several sites have been heated using more than one steam injection well interval per location. Several projects have used three injection intervals, as for example EarthTech and SteamTech.²²

²² Earth Tech and SteamTech (2003): Site 61 Treatability Study Report, Steam Injection. Northwest Main Base, Operable Unit 8. Draft report submitted to US Air Force Flight Test Center, Environmental Restoration Division, Edwards AFB, California.

Steam Enhanced Extraction (Heron and Crisp)

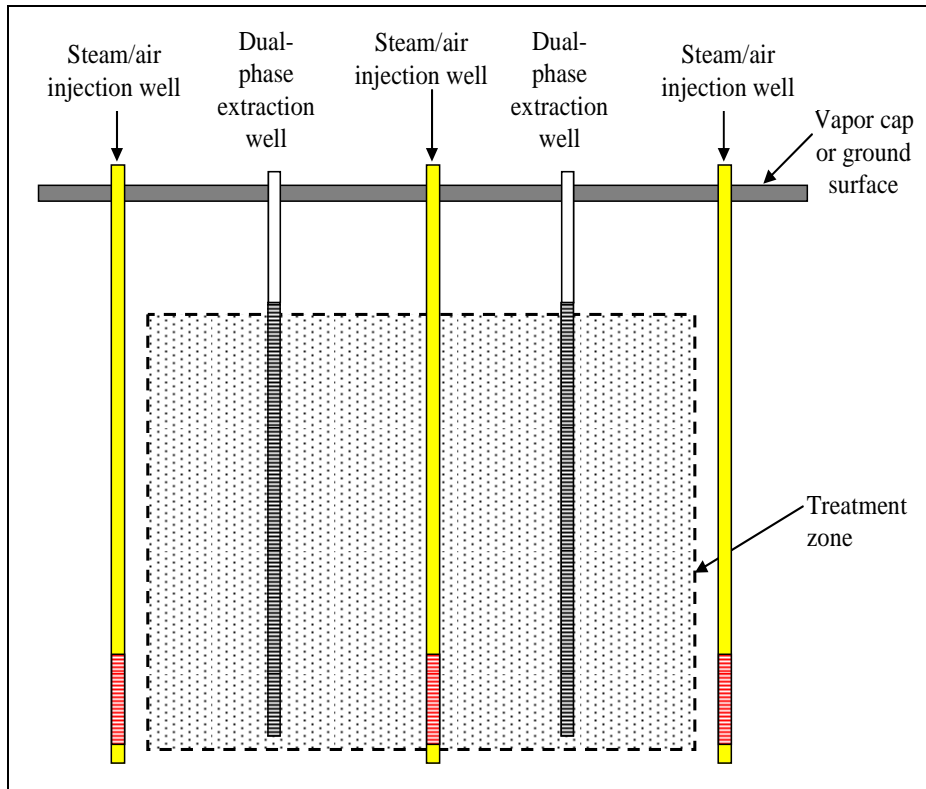

Figure 5. Generic cross-section for an SEE site with one injection interval

Each site is analyzed in detail, and both the steam delivery and the vapor and water recovery wells and extraction approach are determined based on site-specific conditions.

A vapor cover is typically used when treating shallow depths. The cover serves three purposes:

1. It provides thermal insulation and prevents contaminants from condensing near the land surface, which will occur if the soil is cool.
2. It prevents rainwater infiltration, which could lead to unwanted cooling of the treatment zone.
3. It provides a vapor seal and increases the radius of capture of the vapor extraction screens.

Temperature and pressure monitoring wells are simple vertical borings used to document performance and pneumatic control during treatment. These are located inside and outside the treatment area, typically at different distances from the operational wells to illustrate the progression of the SEE process in the subsurface.

3.2 Generic lay-out of above-ground components, showing the footprint of a "typical" application

Steam Enhanced Extraction (Heron and Crisp)

The above-ground equipment varies from site to site depending on treatment area size, volume, nature of contamination, and local regulatory requirements for treating the effluents.

The steam generation system was described in Section 2.1.

A typical extraction and treatment system is shown in Figure 6. Effluent fluids are condensed before vapor treatment, and conventional vapor and water treatment technologies are used. The heat exchanger/condenser reduces the temperature of the extracted vapors to remove steam and increase the efficiency of the water and vapor separator. The vapor treatment system is assumed to consist of a granular activated carbon (GAC) system and a vacuum blower. Other vapor treatment options include Catalytic or Thermal Oxidation. Condensate treatment is by liquid phase GAC filtration (sometimes preceded or replaced by air stripping).

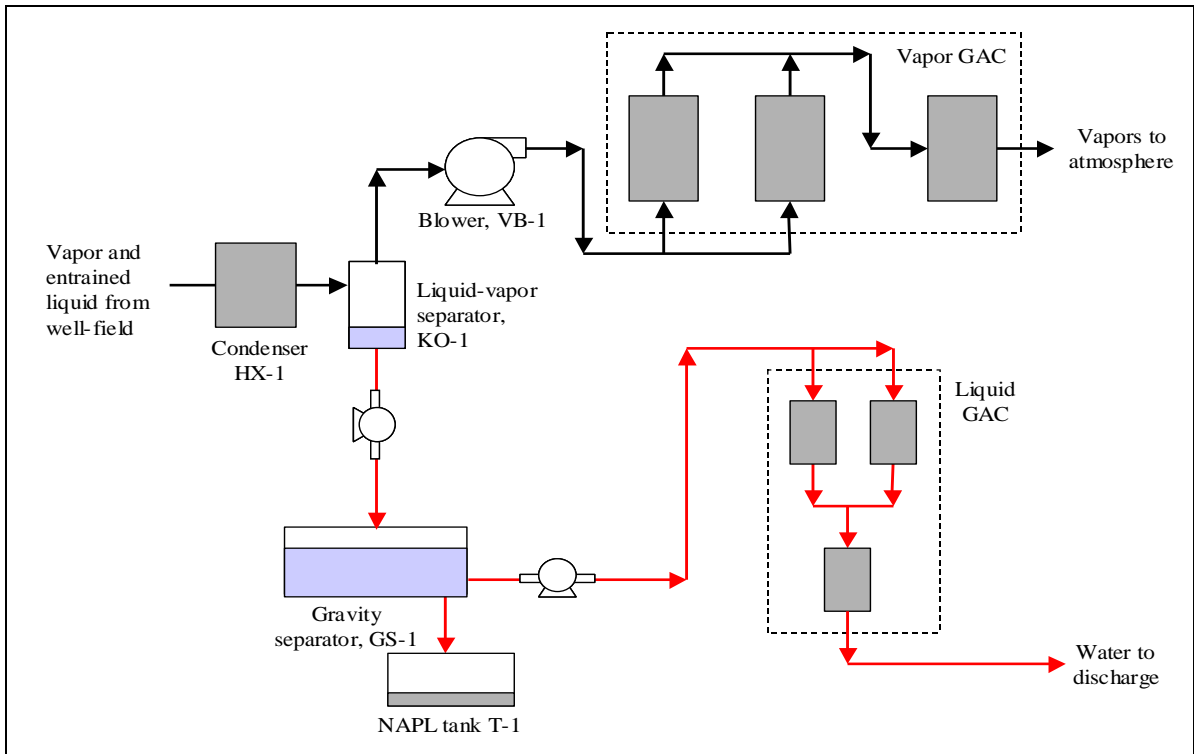

Figure 6. Effluent Treatment System

Since the extracted fluids include water, potentially NAPL, air, and steam at varying temperatures and pressures, the treatment system must be a robust combination of cooling, separation, and treatment units previously proven to be effective for their functions.

For sites with large contaminant mass loading, thermal oxidation or other methods capable of handling the high recovery rates are used for vapor treatment.

Steam Enhanced Extraction (Heron and Crisp)

The surface layout is dictated by site-specific conditions such as the location of utility connections, obstructions such as buildings, and an effort to minimize the piping runs from the well field area to the treatment process. For small sites, the treatment system is placed on a trailer or in a container and mobilized to the site as one unit. For sites requiring large treatment components, individual process equipment units may be mobilized and connected at the site.

3.3 Special utility requirements (power, water, surface cover, security, etc.)

The required utilities are:

- Power (480 V, 3-phase)
- Water (for drilling, cleaning, office trailer, steam generation, and sometimes for the process if using a cooling tower or wet acid gas scrubbing)
- Gas or diesel when fuel is used for steam generation and sometimes for off-gas treatment (such as an oxidizer) or for generating power as a back-up
- Telephone and Internet for communications and process controls.

At some sites, plant steam is used, which reduces the demand for water and fuel.

3.4 Is the process configured differently if the contaminants are below the water table?

While the process components are the same, water recovery rates may be much higher for applications below the water table, especially where control of groundwater flow towards the treatment zone must be controlled. The process equipment is very similar whether the SEE is applied above or below the water table. Vapor and liquid extraction is important in all cases.

4. Process Information

4.1 Typical durations of applications, and how does one decide to turn it off?

For VOC sites, typical durations are between 2 and 6 months, depending on site-specific requirements and the chosen well spacing.

For SVOC sites, typical durations are between 6 months and 1 year. Some sites have taken longer, when coupled with enhanced natural attenuation, or when a very large volume is treated in stages.

Performance is typically based on soil concentrations, since soil can be readily sampled during operation, using methods identical or similar to those tested and documented by Gaberell et al.²³ The criteria for turning off the system are typically the same as the

²³ Gaberell, M., A. Gavaskar, E. Drescher, J. Sminchak, L. Cumming, W-S. Yoon, and S. De Silva. 2002. Soil Core Characterization Strategy at DNAPL Sites Subjected to Strong Thermal or Chemical

Steam Enhanced Extraction (Heron and Crisp)

criteria for successful remediation—the system is operated until the client has regulatory approval that the remedy is complete.

Sampling of soil eliminates a classical problem—groundwater rebound occurring after the treatment. By sampling the phase from where rebound would originate (by desorption and diffusion out of bypassed solids), the risk of post-remediation contaminant concentration increases is minimized/eliminated.

For some sites without specific numeric cleanup standards, other parameters are used to determine when to cease operation:

- Groundwater concentrations (although these are hard to use due to the complex chemistry at elevated temperatures and difficulty in collection of representative samples without loss of the contaminants). Groundwater samples can potentially show more impressive remediation results due to the low solubility of most VOCs in hot water near the boiling point. Basing the decision to stop treatment on such samples may be risky—and rebound could occur during cool-down.
- Target treatment temperature. This would be applied to the coolest locations within the target treatment zone and used to focus the heating process towards the end of the operational period.
- Diminishing recovery of contaminants while ensuring that the heating process and fluid extraction process are operated according to specifications. This can be risky, since diminishing returns can be reached without treatment of the entire targeted volume, as documented as an interim result at the Young-Rainey STAR project²⁴, where the discovery of a cool area led to focused heating and more complete remediation after the vapor recovery had dropped to low levels temporarily.

Site-specific performance goals are negotiated and typically made part of the contract for the SEE project. They typically tie directly into the regulatory demands for site closure or remedy acceptance, such that the client and the SEE contractor work toward the same objective.

4.2 Typical monitoring/diagnostics for the technology during operation (i.e., how do you know it's working?)

The monitoring includes:

- Hydraulic control (documented using groundwater elevation monitoring).
- Pneumatic control (documented using soil gas pressure monitoring).

Remediation. Paper 1E-07, in: A.R. Gavaskar and A.S.C. Chen (Eds.), *Remediation of Chlorinated and Recalcitrant Compounds*—2002.

²⁴ Heron, G., S. Carroll, and S.G.D. Nielsen. 2005. Full-Scale Removal of DNAPL Constituents using steam enhanced extraction and electrical resistance heating. *Ground Water Monitoring and Remediation*, 25(4): 92-107.

Steam Enhanced Extraction (Heron and Crisp)

- Subsurface temperatures (documented using thermocouples, fiber optic sensors or similar temperature monitoring equipment).
- Contaminant removal rates and totals (estimated by sampling the effluent vapor, water, and NAPL). The totals are compared to initial mass estimates, considering the typical uncertainties of such estimates. However, the total mass recovered is never used to determine when to cease operation, due to the uncertainties in initial mass estimates.
- Vapor treatment efficacy (based on vapor samples before and after the treatment unit).
- Water/condensate treatment efficacy (based on water samples before and after the treatment unit).
- Energy balance calculations.
- Interim sampling of soil and/or groundwater within and around the treatment zone (showing reductions in contaminant concentrations compared to original levels). These samples are typically the most important for determining when to cease operation.
- Final confirmatory sampling.

In addition, site-specific monitoring related to health and safety and community monitoring may be conducted.

4.3 Post-treatment issues (time period needed for cooling/access/etc.)

This is site-specific and depends on future site use. Typically, live steam is removed from the subsurface over a period of 1 to 2 weeks while the site starts the cool-down. At some sites, cold water is injected to assist with cooling. When demobilization begins, the subsurface temperatures may be as high as 90°C. Removal of the surface cover enhances the cooling. Demobilization is typically complete between 1 and 2 months after completing the remediation. Then, cooling through convection of groundwater and conduction of heat can take several years before the site approaches ambient temperatures.

5. Technology Selection

5.1 For what scenarios is the technology ideally suited?

Generally, SEE is favored by the following conditions:

- Recalcitrant contaminants not easily addressed by MNA, SVE, or pump and treat. The most suited contaminants would include most CVOCs, DNAPL, and creosote.
- Large contaminant mass and concentrations, with significant NAPL presence, such as large fuel spills with substantial light non-aqueous phase liquid (LNAPL)

Steam Enhanced Extraction (Heron and Crisp)

accumulation on a water table (so less aggressive, cheaper methods are ineffective).

- Sites with a driver to clean within a relatively short time frame (where long-term solutions suffer due to insecurity about when they can be shut off).
- Sites deeper than 10 ft (the wells can readily be extended deeper without much additional cost).
- Sites where excavation is unpractical or expensive (so SEE can compete on a unit cost basis).

SEE is potentially partially suited for fractured rock sites. To date, three pilot test demonstrations have been conducted, with varying degree of success. Highly weathered and fractured rock sites with significant mass above the water table are the most promising candidate sites for SEE in rock.

5.2 Under what conditions is the technology "challenged"?

The following conditions challenge the applicability of SEE:

- Very shallow and wide-spread contamination. For such sites, heat losses may become prohibitive due to the large surface area, and the injection rates are limited by the weight of the overburden, restricting injection pressures to 5 psig or less.
- Contamination present under structures where vertical drilling is prohibited. SEE can readily be done using angled or horizontal borings, but the complexity and cost of the drilling and installation increases significantly compared to vertical installations.
- Sites dominated by low-permeability materials such as clay, fine silt, or competent bedrock with sparse fracturing. Intrinsic permeabilities below 0.1 darcy, equivalent to a hydraulic conductivity of 10^{-4} cm/sec, are considered the lower range for SEE applications. For sites with tighter zones, combinations with ERH or TCH may be applicable.
- Sites with a very stringent numerical cleanup standard for soil and groundwater and a heterogeneous geology. Generally, it is difficult to predict the exact steam migration paths and heating pattern. Fluid-based delivery is more sensitive to heterogeneity and permeability contrasts than other heating technologies, like TCH, which relies on thermal conduction.

Typical concerns about geotechnical stability and damage to foundations, buildings, or underground utilities are dealt with relatively easily on a site-specific basis, and have not been a significant barrier to SEE implementation.

Hot Air/Steam Injection Thermal Remediation Using Large Diameter Auger (LDA) In Situ Soil Mixing

by

Phil La Mori and Elgin Kirkland (FECC Corporation)

1. Overview of Technology

1.1 One paragraph description of the state of the thermal application

Thermal treatment of contaminated soils and groundwater by in situ soil mixing using large diameter augers (LDA) while injecting hot air and steam is an effective way to remove source zone VOCs, SVOC and total petroleum hydrocarbon content (TPHC) contamination. The technology operates one treatment cell at a time by advancing a single 6-ft to 10-ft auger to depths of over 70 ft.²⁵ During active mixing the permeability increases, permitting the soil and groundwater to be treated evenly by the injected high-pressure hot air and steam. Steam heats the contaminated soil and groundwater to a temperature of approximately 75°C, thermally desorbing the VOCs and volatilizing the non-adsorbed VOCs, while the air carries the volatilized off-gas contamination to the surface for capture and treatment. The process, which appears to follow pseudo first-order kinetics, is very effective in removing a large percentage of VOCs during the early treatment stages but requires extended treatment times to further increase the percentage of removal, i.e., there is a diminishing return for thermal treatment versus cost. Typically the in situ thermal technology removes 90% to 97% of the VOC and 50% to 90% of the SVOC.

1.2 New improvements to the technology over the past 5 years

The major improvement to the technology over the last 5 years has been the development of the combined thermal remediation followed by injection of zero valent iron (ZVI) powder in a water/guar slurry for remediation of chlorinated DNAPL source zones. The ZVI continues the remediation after the thermal treatment has stopped. This approach takes advantage of the strengths of both treatment technologies; for thermal treatment this is the effective removal of large amounts of contamination early on and the mixing, distribution, and dissolution of the DNAPL that allows the iron to continue remediation of the chlorinated VOC long after the drilling unit has been removed. Removal efficiencies of over 99% are routinely achieved at significant cost savings when compared to thermal treatment alone.

²⁵ Dual 5- to 7-ft diameter augers are also used.

2. Energy Delivery/Heating Information

2.1- Basic conceptual overview of the energy delivery/soil heating process (i.e., a conceptual drawing showing the basic components and a simple conceptual time-series of energy transfer/heating in the subsurface)

The technology consists of three main units: 1) the track mounted crane with the drill unit and hot air, steam, and reagent injection unit; 2) an off-gas capture and process and treatment system; and 3) a Data Acquisition System (DAS) and a process control system. These components are configured to meet site-specific conditions and vary depending on the site conditions, characterization, and cleanup requirements.

The drill platform, which contains the drilling system and air, steam, and reagent dispensing systems, is attached to a track mounted crane that moves around the site on mats. The drill platform turns the drill bar, called the Kelly, which has one end attached to single bladed auger, 6 to 10 ft in diameter, is capable of penetrating the ground surface to depths in excess of 70 ft. The top end of the Kelly is attached to the crane and provides the pathway for the air, steam, and reagent injection. From there the treatment agents travel down a pipe inside the Kelly and are injected into the soil by ports along the trailing edges of the two-bladed auger. Thermal treatment is achieved by injection of hot air and steam. Steam, which is generated by boilers with adequate total capacity, e.g., 20,000 lb/hr at 335°F, provides the energy to volatilize VOC and SVOC. Hot air, which is channeled to the surface along an annular space created by the rotating drill Kelly, entrains the volatilized VOC and SVOC and TPHC and transfers them to the surface where the off-gas is captured and treated. The ZVI slurry, which is mixed in batches up to 600 gallons, is injected into the soil through the same ports as the steam and air, either separately or with the steam and air. Figure 1 provides a conceptual overview of the thermal treatment operation and equipment.

The off-gas capture system consists of a steel can (shroud) placed on the surface covering the drilling area. The diameter of the shroud is approximately 1.5 times the diameter of the auger to ensure complete capture of the off-gas. The hot off-gas (100°F to 185°F) is removed from the shroud and is passed through a gas conditioning unit by a blower operating from 750 to 1200 CFM. The gas conditioning unit cools the gas to 90°F to 100°F and removes the water vapor and dirt particles before being sent to a contaminant destruction unit such as a catalytic oxidizer, flameless thermal oxidizer, or thermal oxidizer. Carbon absorption beds are used as emergency backup should the oxidizer unit need to be shutdown for any reason. For small sites with lower concentration of contamination, the direct use of the carbon bed is more efficient and costs less than the oxidizer.

Large Diameter Auger Combined with Hot Air/Steam Injection (L Mori and Kirkland)

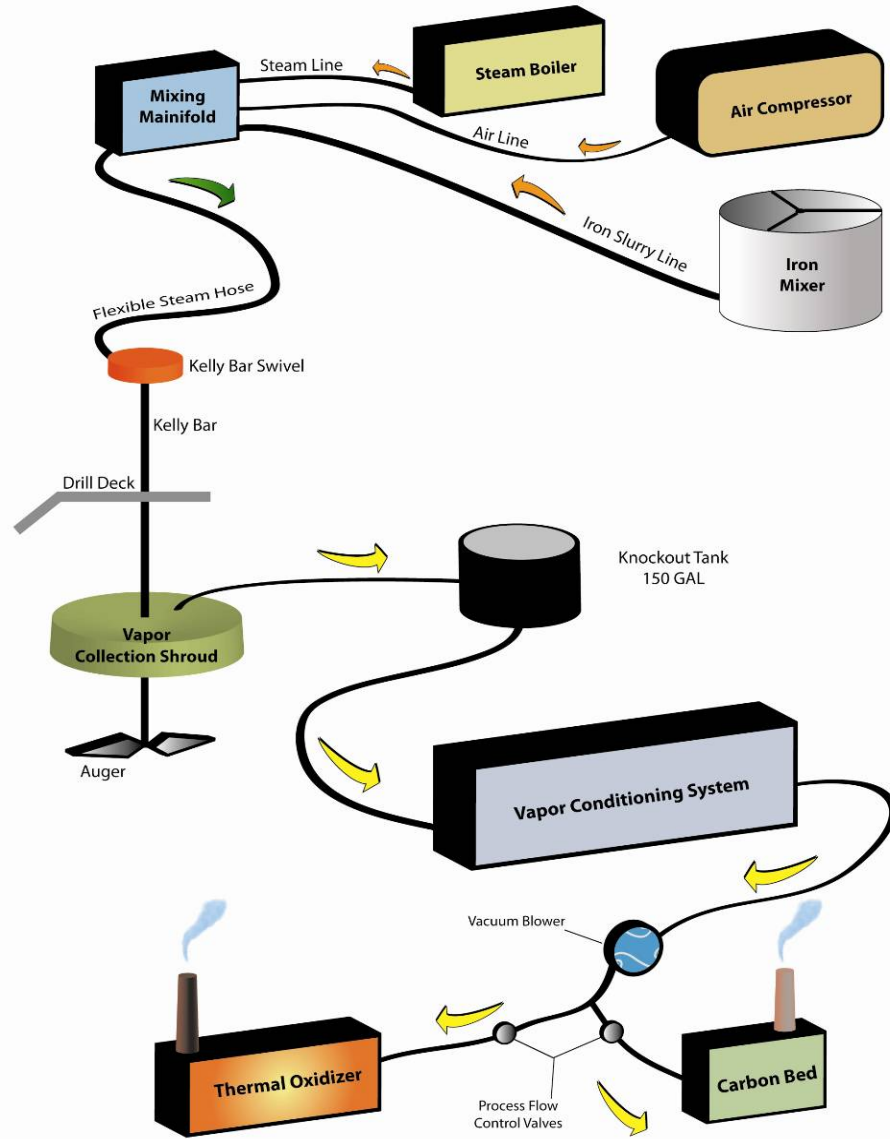

Figure 1. Conceptual overview of the thermal treatment operation and equipment

The DAS and process control system are located in an operations and control trailer unit. This unit contains readouts of instrumentation to monitor and control selected key operational parameters. All the instruments also have inline display for field operational use. Also located in the unit are the flame ionization detectors (FID) to continuously monitor the concentration of total hydrocarbons and the gas chromatographs (GC) that provides periodic data on the identification of the specific compounds in the off-gas stream. The output of the FID, GC, temperature sensors, depth gage, and other key instruments are stored in a computerized logging system operated at a pre-selected recording interval, e.g., 1 to 30 seconds. The measured parameters are displayed in tabular form on a monitor screen while selected key parameters are displayed as a

Large Diameter Auger Combined with Hot Air/Steam Injection (L Mori and Kirkland)

function of time on a second monitor screen. Table 1 provides a list of the measured and displayed operational parameters. A typical display of the key operational parameters is shown in Figure 2.

The measured parameters are uploaded in real time to a remote location that stores, analyzes, and retrieves the data. The operational data can be accessed in real time over the Internet by remotely located technical staff that can then interface with the field operator and take part in the operational decisions.

Table 1. List of measured and displayed operational parameters

Operational Location	Parameters Measured	Key Parameters Displayed for Operation & Control
Auger Drill	Depth	Depth
Steam Production	Flow rate, temperature, pressure	Flow rate
Air Compressor	Flow rate, temperature, pressure	Flow rate
Off-Gas Conditioning Unit	Flow rate, temperature, pressure, off-gas composition by FID and GC	Flow rate, temperature, pressure, off-gas composition by FID and GC
Off-Gas Shroud	Flow rate, temperature, vacuum	Flow rate, temperature, vacuum
Iron Slurry Mixer	Flow rate	Flow rate
Downhole Condition	Temperature	-

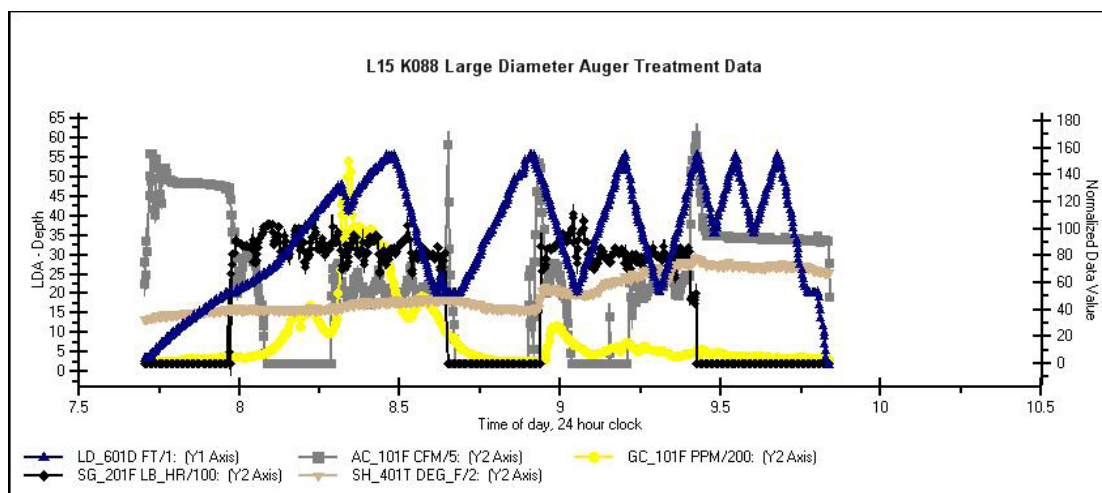

Figure 2. Typical real-time operational display chart

2.2 -Any available information on relationship or current understanding between energy delivery and heating rates (i.e., efficiency of energy conversion to heat)

The main thermal input, i.e., energy delivery, is accomplished by steam generated from boilers as the hot air provides less than 5% of the heating. The subsurface target temperature is about 170°F (76°C). This temperature is high enough to increase the vapor pressure of most VOCs enough to ensure high removal rates. In many cases 170°F is

Large Diameter Auger Combined with Hot Air/Steam Injection (L Mori and Kirkland)

greater than their boiling point or exceeds the boiling point of a mixture of the VOC and water. Heating a column of soil to this temperature usually occurs in less than 1 hour.

A typical sandy soil (located for example in Florida) has a mass of 100 lb/ft³ and contains about 30% porosity. Thus, a saturated cubic foot of this soil contains about 18.8 lb of water and 81.2 lb of sand. Since water has a heat capacity of 1 BTU/lb/°F and the sand has a heat capacity of about 0.25 BTU/lb/°F, the heat capacity of the soil is about 0.391 BTU/lb/°F. Assuming that the column of soil to be heated is 30 ft thick and the auger is 8 ft in diameter, i.e., has an area of 50.27 ft², the mass of soil to be heated is 50 ft² x 30 ft x 100 lb/ft³ = 150,000 lb. The energy to heat the soil from an ambient 70°F to 170°F is approximately 5,850,000 BTU. This calculation indicates that it will take approximately 30 minutes to heat the soil using heat input of 12,000,000 BTU/hr.

This calculation and analysis implies an initial drilling penetration rate of about 1 ft/min. This rate is often difficult to achieve during the initial penetration of the auger because, during the initial penetration, the ground is hard and compacted. Drilling rates of 0.5 ft/min or less are often encountered during the initial pass. When these conditions occur, the heating rate is lowered to control the process.

2.3 - Limitations of the energy delivery/heating process (i.e., what temperatures can be reached, how even is the heat/energy distribution, and do natural phenomena limit the heating?)

The limitation on energy delivery caused by ground conditions and drilling rates was noted above.

There are 3 other controlling factors for the thermal input, the boiling point of water with depth, the stability of the subsurface operation to handle the steam/air flow, and the cooling capacity of the off-gas process treating system. The soil/groundwater can be heated to a maximum temperature of the boiling point of water at depth. In practice the operational temperature limitation is about 70°C to 80°C (158°F to 176°F) in the shroud with somewhat higher temperatures in the subsurface.²⁶ This surface temperature limitation is the result of the fact that the off-gas reaching the surface is saturated with water vapor and this vapor must be removed from the off gas stream before it enters the thermal oxidizer and/or activated carbon beds. Above 80°C the vapor pressure increases rapidly and the heat rejection requirement of the off-gas cooling unit increases quickly and the cost becomes prohibitive. Figure 3 shows the temperature/vapor pressure curve of water.

²⁶ Post treatment temperature surveys show that the temperature at depth approaches the boiling point of water. Downhole temperature surveys taken during treatment also indicated that the soil temperature at depth approaches the boiling point curve.

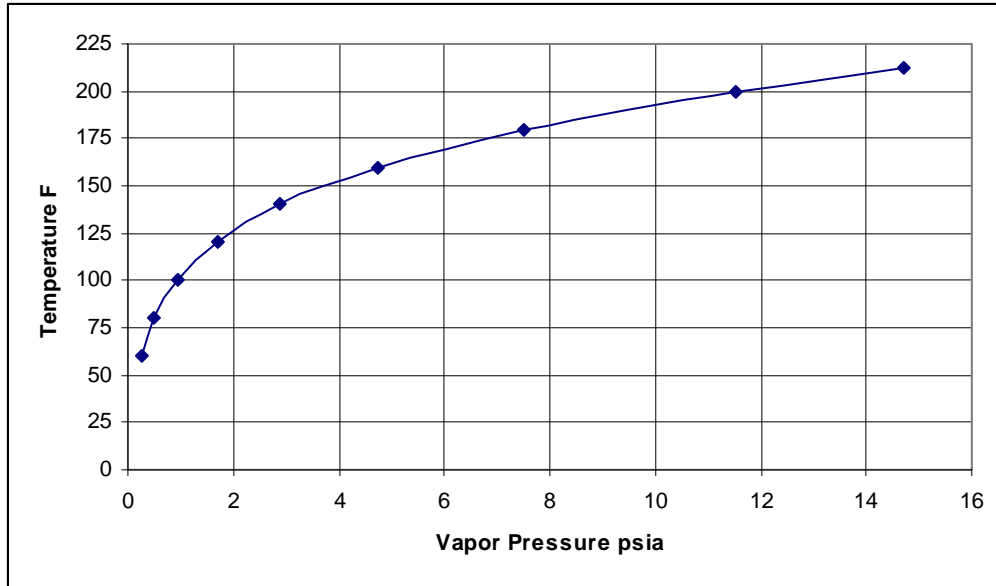

Figure 3. Temperature/vapor pressure curve of water

Also, the subsurface stability of the operation becomes critical at higher temperatures. When the off-gas temperature exceeds about 60°C in the shroud and the downhole temperature is above 70°C, the annular pathway to the surface starts to collapse and open in a pulsating manner causing pressure burping and overpressuring of the shroud. This can result in raising the shroud and the release of contaminated vapors into the atmosphere and work area as well as injecting steam directly into the process system. The steam is injected into the process system because the subsurface temperature will be close to the boiling point, and when the annular column reopens, the first vapors to release are at the atmospheric boiling point and are saturated with steam. This problem is fairly easily controlled by diligently managing the air and steam flow.

2.4 - Unique advantages/disadvantages of this energy delivery/heating approach for contaminant removal or destruction

Some of the advantages of this technology are:

- The below ground mixing provides active remediation and assures that treatment agents contact all the contamination.
- The DAS, including the FID and GC, for process monitoring, feed-back, and control, allow operational decisions to be made real time and allow the remediation to be focused on the depths where there is contamination.
- Immediate removal and capture and/or destruction of the contamination occur through the off-gas treatment system.
- The use of the FID and GC when combined with the off-gas flow permits calculation of the amount of each species removed.

Large Diameter Auger Combined with Hot Air/Steam Injection (L Mori and Kirkland)

- The technology provides the capability to combine the thermal treatment with other treatment processes in a single operation to achieve more complete removal and faster closure at lower cost.
- The technology operates equally well in vadose and saturated zones to 70 ft–100 ft below ground surface.

Another advantage of the technology arises from the fact that water and CVOCs are highly insoluble. The insoluble mixture forms a minimum boiling point azeotrope that is concentrated with the organic compound(s). The lower boiling point and azeotrope properties are believed to improve the thermal removal efficiency of the technology. The following table lists two azeotropes of interest.

Table 2. Data for two important azeotropes

Components	Boiling Point (BP)° C.	Azeotrope BP° C.	Composition Azeotrope wt. %	Upper Layer wt. %	Lower Layer wt. %
Water	100	--	6.30	99.8	0.02
TCE	87.10	73.1	93.7	0.2	99.98
Water	100	--	17.2	99.98	0.01
PCE	121.0	88.5	82.8	.02	99.99

Other innovative aspects of the technology application include measurement and/or control of all key process parameters including downhole temperature, auger depth, and real time measurement of off-gas contaminant concentration using both FID and GC. The FID/GC allow profiling the concentration of contamination vs. depth, providing field personnel real-time data to make decisions such as focusing the interval of treatment on depths showing higher contaminated levels until the removal objectives have been met. This is shown in Figure 4 where the FID increases at 17-ft depth with peaks at 20 ft, 40 ft and 52 ft. This chart shows four thermal treatment passes from 15 ft to 57 ft plus one iron treatment pass (a pass is defined as full movement in both directions).

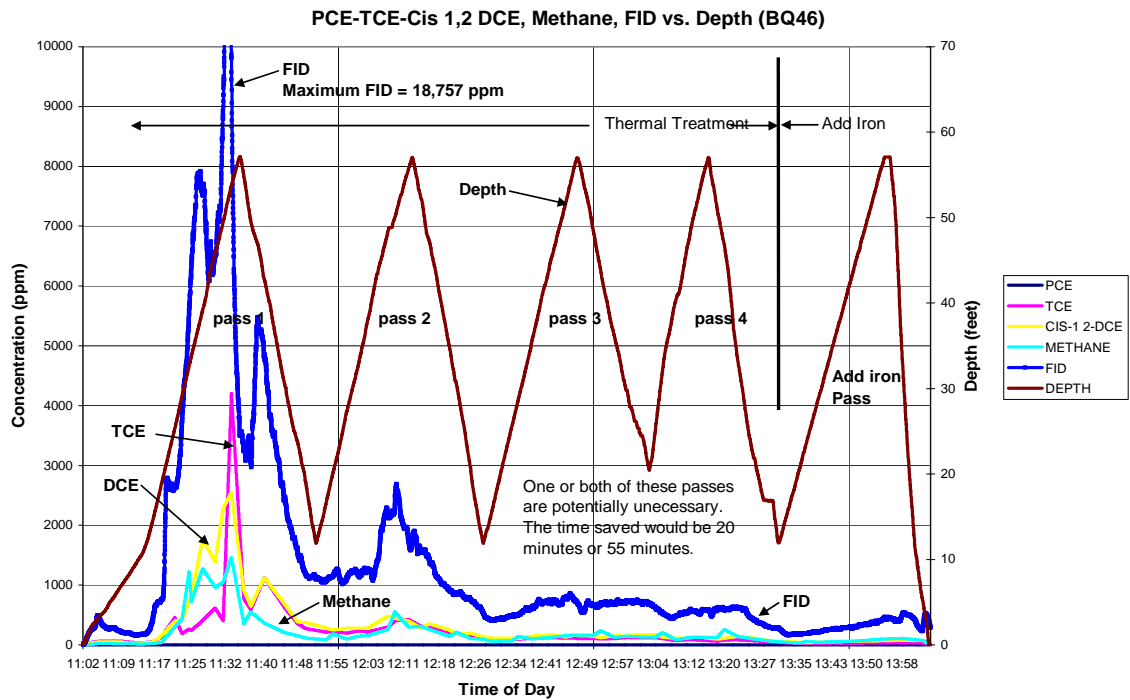

Figure 4. Typical display of key operational parameters

One disadvantage of the technology is the long time required to achieve very high removal efficiencies with the thermal treatment. This is the result of an observed pseudo first order thermal removal rate, i.e., high removal early in the treatment but much lower removal later in the treatment. The actual contaminant removal is believed to be more complex than pseudo first order and is probably made up of air stripping, volatilization, and desorption components. The air stripping and volatilization components are believed to dominate the early removal while the desorption component is much slower and dominates the later remediation. Combining the high early thermal removal with the addition of a second treatment agent has resulted in very high total contaminant removal at a reduced cost. The addition of ZVI for removal of chlorinated VOC has been very effective. The addition of an inorganic oxidizer has been proposed for petroleum hydrocarbons.

Another disadvantage of the technology is the temperature limitations of the boiling point of water and of about 80°C in the shroud. This problem was discussed above. The effect of the azeotrope formation mitigates this to some extent. Experience has shown, however, that the thermal remediation of SVOC is less efficient than for VOC, 60% versus 90%.

2.5 - Is the process applied differently if the contaminants are below the water table?

The LDA thermal treatment technology has been applied separately in the vadose zone and saturated zone as well as in both zones in one treatment cell. There appears to be no obvious difference in the application to either zone. Calculation of the energy required to heat vadose zone soils is about three-fourths of the energy to heat saturated soils. This does not present a problem because the boiler output easily supplies this difference and, as stated above, the initial drilling into the ground is often slowed so that the steam input is cut back to prevent over heating.

3. Process Configuration Information

3.1 - Generic layout of the process showing spacing (heaters, electrodes, wells, temperature, etc.) of in situ components for a "typical" application

The technology operates as a batch process with each cell being remediated separately. Once the cell is remediated to pre-selected criteria, the drill is removed from the cell and set up over the next cell. Figure 5 shows how the cells are laid out and overlapped to insure 100% areal coverage with dimensions for a 7-ft diameter auger. Figure 5 also shows the cross section of the Kelly with its welded angle brackets that create the annulus as the auger rotates. This cross section also shows the 3 inch diameter stainless steel injection pipe.

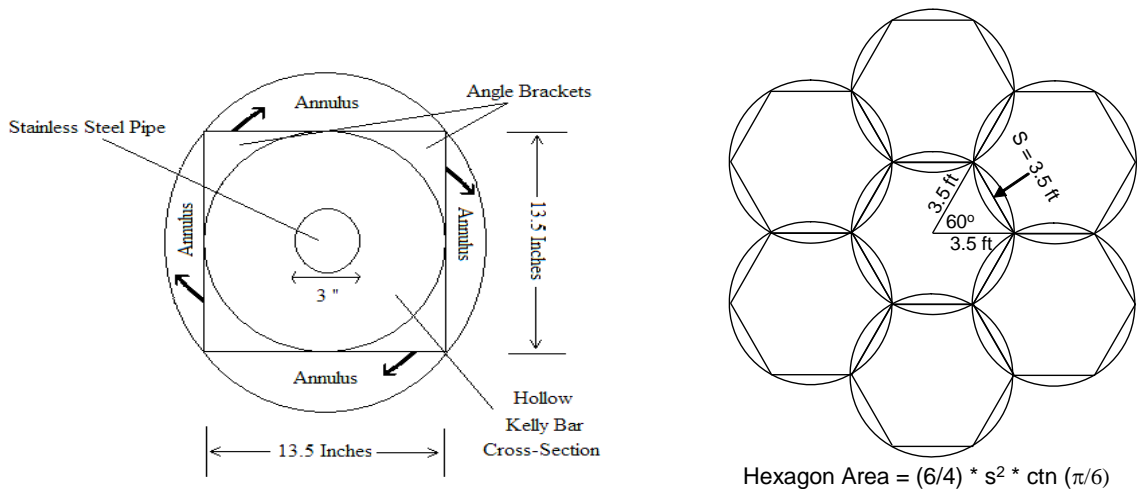

Figure 5. Typical cell layout surface view and Kelly cross section

3.2 - Generic layout of above-ground components, showing the footprint of a "typical" application

A typical layout of the equipment for site remediation is shown in Figure 1.

3.3 - Special utility requirements (power, water, surface cover, security, etc.)

The utility requirements are nominal. A typical operation will require 500 to 1000 kilowatts of electricity, a maximum of 1500 gallons of water per hour and minimal security. An exclusion zone of about 30 meters is maintained during actual operation for personal health and safety (H&S). Experience has shown that this size exclusion zone and operation with a shroud vacuum of over 1 inch water is adequate to control emissions and ensure worker H&S. The equipment operates off of mats, but the site needs to be graded flat and have less than 3° slope.

3.4 - Is the process configured differently if the contaminants are below the water table?

As indicated above, there are no special requirements for operation below the water table.

4. Process Information

- Typical durations of applications, and how does one decide to turn it off?

The decision to turn off the thermal treatment is typically based on two factors: 1) off-gas temperature in the shroud and/or downhole temperature if that measurement is available and 2) the value of the FID, or GC for a key chemical compound like TCE. The temperature component is used to ensure that the downhole soil temperature will provide needed thermal desorption after the treatment is complete. The actual stopping value is a function of the cell contamination as determined by the first pass (a pass is defined as a descent and an ascent to the cell) maximum FID and GC readings.

The FID and/or GC component is used as an indication to turn off the thermal treatment when the reduction in values indicates that extended treatment time is needed to further increase the percentage of removal, i.e., the point where there is a diminishing return for thermal treatment versus cost. Typically this occurs when there is an 80% to 90% reduction in the maximum value observed during the initial pass into the cell. When this occurs the reduction in FID and/or GC values versus time usually becomes asymptotic.

The following table provides a typical decision tree for determining when to turn off the treatment. This table doesn't include GC criteria but these are often used. For example, a GC value of less than 200 ppm TCE might be a criterion for initial FID value between 1000 and 10,000 ppm.

Table 3. Example of LDA thermal treatment completion criteria

Initial Max FID	Shroud Temperature	Final FID*	Comment
< 400 ppm	No criteria	No criteria	In and out and add ZVI
> 400 ppm but <1000 ppm	> 150 F	< 250 ppm	Should be 1 thermal treatment pass
> 1000 ppm but < 10,000 ppm	> 160 F	90% reduction or asymptotic	
> 10,000 ppm	> 170 F	> 80% reduction and asymptotic	FID values as high as 1000 ppm to 2000 ppm are acceptable.

* Measured methane is excluded.

After the thermal treatment is complete, a second treatment agent, e.g. ZVI, can be injected to provide additional long-term remediation for the desorbing contamination. Figure 4 illustrates how this decision process might work. After two complete passes, it was clear that the FID as well as the GC values for TCE and dichloroethene (DCE) had been reduced to over 90% of their initial maximum and that the decrease in values was approaching asymptotic. However the shroud temperature had not yet reached the target temperature of 170°F. Two additional passes were made to heat the cell before iron was added and the treatment completed.

Although the technology is mature, there is limited information available to define the exact values of FID/GC and shroud temperature and when to stop the thermal treatment. A pilot test to determine the decision tree is recommended for most projects. If the pilot test is not included in the budget, it can become part of the site treatment for a modest additional cost.

- *Typical monitoring/diagnostics for the technology during operation (i.e., how do you know it's working?)*

The key monitoring points for process operation are the depth of auger, steam flow, air flow, FID, off-gas temperature and off-gas flow. A GC is useful for determination of the off-gas chemistry profile but is not a requirement to determine the functioning of the technology. In fact, the technology has often been utilized without a GC. These measurements indicate that the process is functioning as well as providing the key control information to determine when the remediation is completed. These data are measured continuously at a selected time interval, e.g. 10 seconds, and also are displayed in tabular and graphical form to the control operator.

- *Post-treatment issues (time period needed for cooling/access/etc.)*

When the cell treatment is completed, there is often a decrease of column length in volume, e.g. ~5%, with the need to add soil to return the site to grade level. This is

Large Diameter Auger Combined with Hot Air/Steam Injection (L Mori and Kirkland) particularly noteworthy in sandy soils. In clay soils there is often an immediate slight increase in volume followed by a slightly greater decrease in volume a day or two later. These volume changes need to be dealt with so that the remediation operation can be completed and also to restore the surface to pretreatment elevations at the completion of the project.

Heating the soils raises their temperature to approximately the boiling point of water as a function of depth. Because most of the sites are relatively thick, e.g. 30 ft to 50 ft, and cover a wide area, the subsurface cools slowly in the absence of cold water influx. Locations where the groundwater flow is measured in inches per day will take from one to two years to cool to their pretreatment temperatures. This presents safety and handling issues for post-treatment verification groundwater and soil sampling.

5. **Technology Selection**

- For what scenarios is the technology ideally suited?

This technology is ideally suited for sites where the advantages of soil mixing and rapid treatment are important. The following sites come under that category:

- Sites with large concentration and mass of contamination. These sites would probably have significant NAPL presence so that other methods would be less effective or ineffective.
- Sites with uneven or variable lithology where other treatment methods would be confounded by differing permeability and contaminant concentration.
- Sites with mostly VOC or lower boiling point SVOC.
- Sites with target volumes above 3000 cubic yards. The mobilization cost is an issue for small sites.
- Sites with stringent cleanup standards. The thermal technology when combined with ZVI will treat chlorinated VOC and when combined with an inorganic oxidizer will treat petroleum hydrocarbons, both to ppb levels.
- Sites where there is a need to achieve cleanup in a short period of time, e.g., brownfields.
- Sites below the water table or in the groundwater.
- Sites where excavation is impractical, i.e., very expensive or difficult because of environmental concerns.
- Shallow sites where the depth is at least 5 ft.
- Sites where focused depth treatment is important.
- Sites with high groundwater flow rates.

- Under what conditions is the technology "challenged"?

The technology is challenged by:

- Smaller sites, e.g. less than 2000 cubic yards, due to the high cost of mobilization.
- Sites with low concentrations are more effectively dealt with by other approaches.
- Site with infrastructure, e.g. overhead lines, buildings etc.
- Sites at great depths, e.g. over 100 feet.

Large Diameter Auger Combined with Hot Air/Steam Injection (L Mori and Kirkland)

- Sites with high boiling point SVOC, although oxidization is a potential solution because the mixing capabilities provide excellent treatment.

Appendix B

Summary of Information Gathered on All In Situ Thermal Technology Applications

