

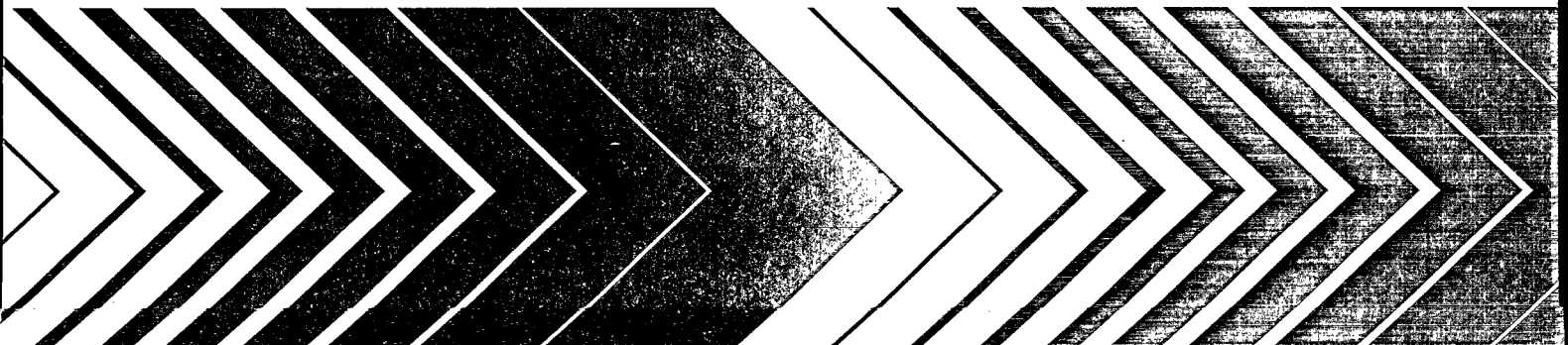

# Seminar Publication

## Landfill Bioreactor Design and Operation

March 23-24, 1995  
Wilmington, DE



## **Contact**

David Carson is the U.S. Environmental Protection Agency (EPA) contact for this report. He is presently with the newly organized National Risk Management Research Laboratory's new Land Remediation & Pollution Control Division in Cincinnati, Ohio (formerly Risk Reduction Engineering Laboratory). The National Risk Management Research Laboratory is headquartered in Cincinnati, Ohio, and is now responsible for research conducted by the Land Remediation & Pollution Control Division in Cincinnati.

**EPA/600/R-95/146**  
**September 1995**

**Seminar Publication**  
**Landfill Bioreactor Design and Operation**

**March 23-24, 1995**  
**Wilmington, Delaware**

**Presented in Cooperation With:**

**Delaware Solid Waste Authority**  
**Solid Waste Association of North America**  
**Environmental Industry Associations**  
**National Renewable Energy Laboratory**

**National Risk Management Research Laboratory**  
**Office of Research and Development**  
**U.S. Environmental Protection Agency**  
**Cincinnati, Ohio 45268**



*Printed on Recycled Paper*

## Notice

This document has been subjected to EPA's peer and administrative review and has been approved for publication as an EPA document. This document is a conference proceedings and, as such, represents the viewpoints of the authors of the individual papers. Operation techniques, technical details, and opinions should not be construed to represent EPA policy.

EPA strives to provide accurate, complete, and useful information. Neither EPA nor any person contributing to the preparation of this document, however, makes any warranty, express or implied, with respect to the usefulness or effectiveness of any information, method, or process disclosed in this material. In addition, EPA does not assume any liability for the use of, or for damages arising from the use of, any information, methods, or processes disclosed in this document. Mention of trade names or commercial products does not constitute endorsement or recommendation for use.

When an NTIS number is cited in a reference, that document is available from:

National Technical Information Service  
5285 Port Royal Road  
Springfield, VA 22161  
703-487-4650



## Foreword

Today's rapidly developing and changing technologies and industrial products and practices frequently carry with them the increased generation of materials that, if improperly dealt with, can threaten both public health and the environment. The U.S. Environmental Protection Agency (EPA) is charged by Congress with protecting the nation's land, air, and water resources. Under a mandate of national environmental laws, the agency strives to formulate and implement actions leading to a compatible balance between human activities and the ability of natural systems to support and nurture life. These laws direct EPA to perform research to define our environmental problems, measure the impacts, and search for solutions.

The National Risk Management Research Laboratory is responsible for planning, implementing, and managing research, development, and demonstration programs to provide an authoritative, defensible engineering basis in support of the policies, programs, and regulations of EPA with respect to drinking water, wastewater, pesticides, toxic substances, solid and hazardous wastes, and Superfund-related activities. This publication is one of the products of that research and provides a vital communication link between researchers and the user community.

This publication is a production of the Municipal Solid Waste and Residuals Management Branch documenting the application of leachate-recirculating municipal solid waste landfills aimed at reducing environmental risk and optimizing landfilled volume by encouraging active biological decomposition within the contained waste system.

E. Timothy Oppelt, Director  
National Risk Management Research Laboratory

## Abstract

These proceedings are from a conference on the subject of municipal waste landfill (MSWLF) bioreactors that was held in Wilmington, Delaware, on March 23 and 24, 1995. Biologically active landfill operation represents a fundamentally different operational technique for MSWLFs because it uses the distribution of moisture in the form of landfill leachate to accelerate naturally occurring decomposition processes to rapidly stabilize the waste mass. The technique also has the benefits of enhanced control of landfill gas, optimization of landfill volume, and, most importantly, the reduction of long-term environmental risk. The seminar was held to determine the level of knowledge about this operational technique.

This report was submitted in fulfillment of Work Assignment number 1-35 under Contract Number 68-C1-0040 with the sponsorship of the U.S. Environmental Protection Agency. This report covers a period from November 1994 to September 1995, and work was completed as of September 1995.

## Contents

|  | <u>Page</u> |
|--|-------------|
| Notice .....   | ii          |
| Foreword .....   | iii         |
| Abstract .....   | iv          |
| Acknowledgment .....   | vii         |
| <br>   |             |
| The Municipal Solid Waste Landfill Operated as a Bioreactor .....  | 1           |
| <i>David A. Carson</i>   |             |
| <br>   |             |
| Landfill Bioreactors: Historical Perspective, Fundamental Principles, and<br>New Horizons in Design and Operations ..... | 9           |
| <i>Frederick G. Pohland</i>  |             |
| <br>   |             |
| Landfill Bioreactor Design and Operation: A New York State Regulatory Perspective .....                                  | 25          |
| <i>Robert J. Phaneuf</i>   |             |
| <br>   |             |
| Design Elements Associated With Leachate Recirculation at Existing, Unlined<br>Landfills .....                           | 41          |
| <i>Stephen R. Harper, Sharon R. Just, Christopher Donohoe, and David A. Carson</i>                                       |             |
| <br>   |             |
| Landfill Bioreactor Instrumentation and Monitoring .....   | 57          |
| <i>Don Augenstein and Ramin Yazdani</i>  |             |
| <br>   |             |
| Long-Term Permeability of Granular Drainage Material .....   | 69          |
| <i>George R. Koerner and Robert M. Koerner</i>   |             |
| <br>   |             |
| Municipal Solid Waste Landfill Bioreactor Technology: Closure and Postclosure<br>Issues .....                            | 81          |
| <i>Jerome J. Leszkiewicz and Peter B. McAulay</i>  |             |
| <br>   |             |
| Landfill Bioreactor Design and Operation: International Perspectives .....   | 123         |
| <i>David J.V. Campbell</i>   |             |
| <br>   |             |
| Test Cells and Bioreactor Landfills in Sweden .....  | 137         |
| <i>Jan-Erik Meijer and Peter Nilsson</i>   |             |
| <br>   |             |
| Leachate Management in Landfill Bioreactor Design and Operation .....  | 153         |
| <i>W. Lamar Miller and Timothy G. Townsend</i>   |             |

|  |     |
|--|-----|
| Incorporating Bioreactor Techniques Into Daily Operation of a Landfill ..... | 169 |
| <i>Richard P. Watson</i>   |     |
| Landfill Gas Enhancement Management .....                                    | 175 |
| <i>John G. Pacey</i>   |     |
| Landfill Leachate Recirculation From an Owner/Operator's Perspective .....   | 185 |
| <i>Jeffrey M. Harris</i>   |     |
| Panel Discussion .....   | 193 |
| Appendix A: Speakers .....   | 229 |
| Appendix B: Final Attendee List .....  | 233 |
| Appendix C: Agenda .....   | 241 |

## Acknowledgment

This publication presents proceedings of the Landfill Bioreactor Design and Operation Seminar held on March 23 and 24, 1995, in Wilmington, Delaware. The seminar afforded an opportunity for information and idea exchange regarding the state-of-the-art of landfill bioreactor technology and the future direction of the operation of the landfill as an engineered treatment unit.

Seminar coordinators would like to acknowledge the cosponsors of the seminar, including the Delaware Solid Waste Authority, the Solid Waste Association of North America, the Environmental Industry Associations, and the National Renewable Energy Laboratory. We would also like to thank the program committee for their contributions: David Carson, U.S. Environmental Protection Agency (EPA); N.C. Vasuki, Delaware Solid Waste Association; and Frederick G. Pohland, University of Pittsburgh. In particular, we would like to thank Mr. Vasuki and the Delaware Solid Waste Authority for hosting the tour of the Sandtown, Delaware, Central Solid Waste Management Center. In addition, we would also like to recognize the valuable contribution of the following individuals, who reviewed the document:

- A. Basel Al-Yousfi, Union Carbide
- Carlton Wiles, Department of Energy, National Renewable Energy Laboratory
- Frederick Pohland, Department of Civil and Environmental Engineering, University of Pittsburgh
- David Carson, National Risk Management Research Laboratory, U.S. EPA
- Debra Reinhart, University of Central Florida

Finally, we would like to recognize the seminar speakers, who put so much time and energy into preparing their presentations and papers.

The success of this seminar, in terms of attendance and participation, suggests that a new era in landfill design and operation has arrived. We hope that this publication will contribute to the appropriate use of the landfill as a bioreactor.

The first part of the document discusses the importance of maintaining accurate records of all transactions. It emphasizes that every entry, no matter how small, should be recorded to ensure the integrity of the financial statements. This includes not only sales and purchases but also expenses and income. The document provides a detailed list of items that should be tracked, such as inventory levels, accounts payable, and accounts receivable. It also outlines the procedures for reconciling these accounts and identifying any discrepancies.

The second part of the document focuses on the classification of expenses. It explains how to distinguish between capital expenditures and operating expenses, and how to allocate costs to different departments or projects. This section includes a table that categorizes various types of expenses, such as salaries, rent, utilities, and depreciation. The document also discusses the importance of proper documentation for each expense, including receipts and invoices, to support the entries in the financial records.

The third part of the document addresses the issue of asset management. It describes how to record the acquisition of new assets, such as equipment or vehicles, and how to track their depreciation over time. The document provides a formula for calculating depreciation and explains how to adjust the book value of an asset as it is used. It also discusses the process of disposing of assets and how to record the resulting gain or loss.

The fourth part of the document covers the topic of liability management. It explains how to record the incurrence of liabilities, such as loans or accounts payable, and how to track the repayment of these obligations. The document provides a table that lists common types of liabilities and their corresponding accounting entries. It also discusses the importance of maintaining accurate records of interest payments and other costs associated with liabilities.

The fifth and final part of the document discusses the preparation of financial statements. It explains how to use the recorded data to calculate key financial ratios and metrics, such as the profit margin and the current ratio. The document provides a step-by-step guide to the preparation of the income statement, balance sheet, and cash flow statement. It also includes a checklist of items to review before finalizing the financial statements to ensure their accuracy and completeness.

# **The Municipal Solid Waste Landfill Operated as a Bioreactor**

---

David A. Carson

National Risk Management Research Laboratory, U.S. Environmental Protection Agency,  
Cincinnati, Ohio

---

## **Introduction**

Recent statistics show that the vast majority of waste in the United States is disposed of in landfills. It is a worthwhile activity to optimize the utility of landfilled volume and to minimize the need for siting of future landfills. When waste is deposited in landfills, the containment strategy is to isolate the waste from man and the environment by keeping the waste in its as-received condition. This is accomplished through a system of natural and synthetic components to minimize infiltration and maximize leachate collection and disposal. This is coupled with landfill operation and management practices designed to sustain the facility during and after waste placement. When a landfill cell is closed, another landfill cell must be prepared to receive waste. Meanwhile, the closed landfill cell is isolated from water and air. Biological activity rapidly goes dormant.

The ultimate goal is to maintain the structure of the traditional landfill (currently required by regulation to be 30 years after closure). What is the fate of the landfill after 30 years? This question is the focal point of this conference and of the U.S. Environmental Protection Agency's (EPA's) research effort. If the aforementioned traditional landfill containment system develops a leak, this may allow the introduction of air and water. Depending on the severity and location of the leak, this could cause several biological reactions to begin, producing gas and leaching potentially toxic materials out of the landfill containment system, usually requiring immediate short-term remedial action and later, expensive repair (one of the provisions of the Comprehensive Environmental Response, Compensation, and Liability Act [CERCLA] program).

This conference examines an alternative approach to landfill operation that greatly minimizes long-term risks associated with potential landfill containment system failure. The system involves the simple concept of delivering leachate to the waste mass in a controlled manner to control decomposition and minimize future risk factors. This new type of landfill is called a bioreactor. This method represents the future of waste disposal because it transforms waste disposal practice from a passive system to an active process.

## **Methodology**

EPA embarked on a research program in conjunction with academia and private industry in an attempt to constructively harness the potential energy of the common landfill. It was envisioned that the landfill was a resource of energy that was not utilized in traditional landfilling practice. As landfilling matured and engineering controls tightened, landfill gases

---

were recovered and found to be useful in many situations. Later, landfill leachates were under scrutiny, and the biological energy of the landfill was thought to have the capability of also treating the leachate when a system was designed specifically for this task.

With gases and liquids under review, the landfill as a system was examined to determine if the landfill could be operated as a relatively crude biological reactor, able to stabilize itself using natural anaerobic biological process that could be encouraged via engineering design and operational techniques. These techniques simply encourage natural processes that are interrupted and made less efficient as a result of the containment system. This research program has evolved to focus on stabilization of waste and has moved into pilot-scale research and the initiation of full-scale applications of this technique at currently operating landfills, described herein.

To gather data and analyze results, EPA initiated a study of this operational technique for municipal solid waste (MSW) landfills in the early 1980s (1). EPA-sponsored individual experiments are designed to compare landfill cells operated in a different manner, either wet or dry. These experiments are expensive, time-consuming, and require a long-term commitment to obtain results due, in part, to the magnitude of full-scale research. Model landfills were constructed inside steel lysimeter tubes approximately 1 m in diameter by 3 m in height. These models were designed to examine the effects of the addition of several organic wastes, such as wastewater sludge, on a matrix of primary pollutants. Researchers found that by simply reinjecting common MSW landfill leachate under controlled sequences that the following benefits could potentially be realized at full scale:

- Expansion of landfill capacity through volume reductions induced by biological decomposition of MSW in the landfill, reducing the actual number of landfills that must be sited.
- Improved control of the quantity of recoverable landfill gases (methane and carbon dioxide) through controlled biological reactions.
- Toxicity reduction of the MSW mass through biological decomposition and immobilization in the waste mass, resulting in lower pollutant concentration in leachate.
- Reduced postclosure monitoring time due to toxicity reduction.

Building upon this fundamental research, EPA sponsored further research to take this operational technique to the field in the form of pilot-scale landfill test cells (2). Anticipating the opportunity to build on this research, full-scale landfills were sought and selected to prove the technology at full scale. One landfill was selected near Gainesville, Florida, and another landfill project is in the construction phase near Rochester, New York (see Table 1).

In addition to these activities, EPA is tracking related projects in the United States and around the world. EPA is also pursuing the application of this technology in a remedial manner at an unlined, uncontrolled landfill.



**Table 1. U.S. EPA Landfill Bioreactor Project**

| <b>Location</b> | <b>Scale</b> | <b>Description</b>                             | <b>Status</b>         | <b>Ref.</b> |
|-----------------|--------------|--|-----------------------|-------------|
| Georgia         | Lab          | Model landfill lysimeters                      | Completed in 1993     | 1           |
| Delaware        | Pilot        | Test cells 2 each, 1 acre each, wet versus dry | Operating for 2 years | 2           |
| Florida         | Full         | Active fill - 6 acres                          | 80 percent complete   | 3           |
| New York        | Full         | Active fill - 10 acres                         | Filling               | 4           |
| Ohio            | Full         | Remediation of existing landfill               | Planning              | 5           |

*Leachate Recirculation Process*

Methods of introducing leachate to refuse that have been utilized to date include surface spraying, surface ponds, vertical injection wells with and without wicks, and horizontal surface infiltration devices. Generally, additional costs for leachate recirculation components are relatively low. For proper execution of a leachate recirculation system at a modern MSW landfill, the following components are generally considered to be necessary:

- A composite lining system composed of a single or double composite liner (compacted soil and a geomembrane), with a leachate handling system.
- MSW placed at a density determined to accommodate leachate recirculation.
- Daily cover that does not significantly affect the continuous passage of moisture through the landfill from top to bottom (this rules out many traditional MSW landfill daily cover practices).
- A leachate reintroduction system, contained within the landfill enclosure, that only uses native landfill leachate or fresh water.
- An active gas collection system as part of a comprehensive landfill cap design.
- A landfill cover capable of providing modern landfill cap functionality that can maintain integrity as the leachate recirculation process causes landfill volumes to decrease.
- A trained landfill operator who understands the daily operational requirements of a leachate-recirculating landfill and gas recovery management program.

Many of these issues remain engineering challenges that need to be resolved in full-scale implementation. A schematic of a leachate-recirculating MSW landfill is shown in Figure 1.

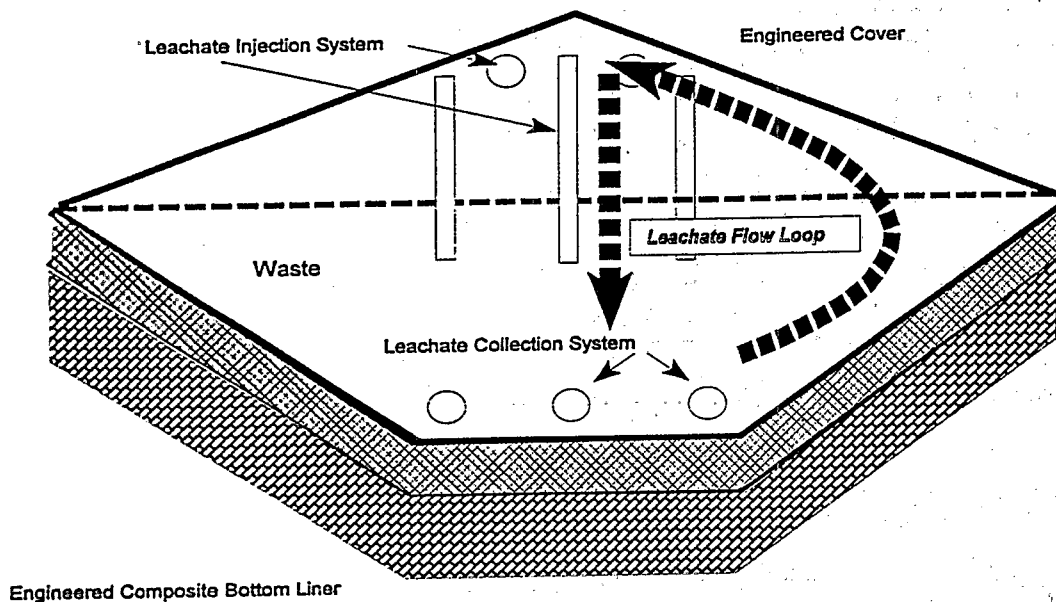

**Figure 1. Schematic of leachate-recirculating landfill bioreactor.**

The leachate recirculation process is fundamentally simple, requiring relatively minor changes from the current designs. The number of variables involved to demonstrate control over the reactions in these studies are numerous, however, and every attempt is made during experimental design to control the number of variables. Operator training is critical, and outputs from these projects will emphasize operator control by providing operational guidance. As a matter of practicality, experiments to evaluate materials that may be added to the landfill during filling to enhance degradation have been relegated to future experimentation. Possible additions include waste preprocessing, microbiological additives, waste sludge, gases, or the control of temperature of the waste mass.

Concurrent with EPA research, other research projects are underway in the United States and around the world. There are new projects being initiated in California, Florida, and New Hampshire, and underway around the world in Canada, Australia, Germany, Denmark, Italy, Sweden, Japan, and the United Kingdom. The collective database formed in the study of these landfills will supply enough information to assess the performance of this operational technique in the field.

## Results

The status of active EPA-sponsored projects are described here. The effort has benefited from the active participation of major waste management companies in the United States and

from the collaborative research efforts of EPA's colleagues. Their participation is gratefully acknowledged. Summary results to date are derived from the following projects.

*Laboratory Lysimeter Studies: Georgia and Pennsylvania*

Completed in 1993, the research performed at the Georgia Institute of Technology and University of Pittsburgh showed leachate recirculation offers rapid and complete stabilization of the landfilled waste masses. The system proved resilient to toxic loadings that caused retardation but not defeat of the stabilization process. The study showed that landfills are capable of biological and physicochemical reactions to attenuate waste constituents via reduction, precipitation, and matrix capture for heavy metals, as well as biotic and abiotic transformation and sorption for organic materials. The study also showed that the performance of the bioreactor landfill can be monitored with leachate and gas parameters during significant phases of the reaction. The study concluded that the bioreactor landfill design is viable and offers a significant improvement over traditional landfill operation (1).

*Pilot-Scale Landfill Test Cells: Delaware*

Two 1-acre pilot-scale landfill test cells are currently operated by the Delaware Solid Waste Authority in Sandtown, Delaware. Two identical cells were constructed: one operated traditionally (dry), and the other employed leachate recirculation. The cells have been operating for approximately 2.5 years, and although the data are being analyzed, preliminary results show that trends described in early laboratory research are repeated in the field (2).

*Full-Scale Landfill Project: Alachua County, Florida*

The first of two full-scale landfill projects was selected near Gainesville, Florida. The landfill is operated by the City with assistance from the University of Florida, engineering firms, and others. The landfill is approximately 80 percent full, and leachate recirculation systems are being installed as filling progresses. A nearby landfill at that site has performed this technique in a less sophisticated manner, utilizing surface infiltration ponds in previous years with success (3). Preliminary testing of the leachate recirculation system has proven its viability, evidenced in data collected from leachate, gas, and solids analyses.

*Full-Scale Landfill Project: Monroe County, New York*

The second full-scale landfill project is in the construction phase near Rochester, New York. EPA is assisting the New York State Energy Research and Development Authority (NYSERDA) in its efforts to study how this landfill operational technique may achieve complementary goals of environmental protection and the potential for enhanced energy production through gas recovery (4). This landfill construction is progressing at a relatively slow pace and is approximately 40 percent full.

### *Remediation Project: Ohio*

An unlined landfill is under study in Cincinnati, Ohio, for application of leachate recirculation as an alternative to pumping and treating ground water at an uncontrolled preregulatory landfill. The project is significantly more complicated due to the absence of a bottom liner, but researchers are convinced that ground water can be controlled and barriers can be constructed to accommodate leachate recirculation at the site (5). A feasibility study is in final draft status, and the project has entered into its second phase to complete preconstruction details.

### *Comprehensive Study: University of Central Florida*

A comprehensive evaluation of active landfill bioreactor projects is underway at the University of Central Florida (6). Researchers are compiling data from these EPA-sponsored projects, other American projects, and projects from around the world by site visitation and interactions with specialty groups such as the International Energy Agency's Landfill Gas Expert Working Group. Specific projects aim to assess moisture distribution of the leachate into the waste mass through computer models. This will assist designers in the configuration of the injection system and may lead to guidance on placed waste densities that will accommodate leachate recirculation.

### **Bioreactor as a Remediation Tool**

While the primary focus of this research is the design and operation of new landfill biological reactors, remedial feasibility is also being investigated. The biological reactor as a remedial measure is similar in concept but in most cases suffers from the lack of a physical barrier system. It is thought, however, that a hydraulic control system can be constructed for many preregulatory landfills via an integral system of interceptor and collection trenches, barriers, and vertical and/or horizontal wells. The opportunity to economically apply this system is site-specific, and when the long-term costs of the presumptive remedy of remedial cap with pumping and treating of leachates are calculated, a rapid biological remediation can become an economically attractive alternative.

### **Future Research**

As landfills continue to evolve as sophisticated waste disposal and decomposition facilities, there are new goals anticipated for the future. Foreseen is a waste management park that will involve centrally located management of a variety of waste streams, of which a landfill will provide a necessary service. Wastewater, sludges, composted waste and green waste, MSW materials recovery facilities, combustors, and recycling facilities require inputs and outputs that can be integrated, resulting in more efficient processing of MSW.

The landfill could produce an output of low- to medium-grade compost that could be used for soil amendments in roadways and earth works. Gas from the landfill could be used to generate electricity or to power collection vehicles. The landfills could be arranged in a

turntable-type arrangement so that cell 1 of the landfill can be constructed, filled, covered, and placed under leachate recirculation, then on to cell 2, where the process is repeated, and so on. When all cells are complete, the operator returns to cell 1, where the contents could be mined (7), with any originally missed recyclables and new compost removed, the bottom lining inspected and replaced when necessary, and the entire process begins again.

While this technique will likely not eliminate the need to site new landfills, it will significantly increase the useful life of landfills when constructed to operate as bioreactors.

### Summary

Landfills are currently designed and operated to serve as containment systems. While originally designed to entomb waste, the modern landfill has evolved into a more technically advanced containment system, with sophisticated controls and operational techniques. The landfill of the future will protect human health and the environment, will degrade the waste mass in the landfill, and will be reusable, allowing the waste to be excavated so the cell can be inspected and refilled as part of an integrated waste management park.

### For More Information

Please contact David Carson, U.S. Environmental Protection Agency, National Risk Management Research Laboratory (ML-CHL), 26 W. Martin Luther King Drive, Cincinnati, Ohio, 45268-3001, USA, at (513) 569-7527.

### References

1. U.S. Environmental Protection Agency. 1993. Behavior and assimilation of organic and inorganic priority pollutants codisposed with municipal refuse, Volumes 1 and 2. EPA/600/R-93/137a,b (NTIS PB93222198 and 93222206). Risk Reduction Engineering Laboratory, Cincinnati, OH.
2. Vasuki, N.C. 1993. Practical experiences with landfill leachate recirculation in pilot and field scale units. In: Proceedings of the 31st Annual International Solid Waste Exposition, Solid Waste Association of North America, San Jose, CA (August 3).
3. Townsend, T., and W.L. Miller. 1993. Alachua County Southwest landfill bioreactor project. In: Proceedings of the Madison Waste Conference, Madison, WI (September).
4. Babcock, J., and J. Reis. 1993. Monroe County's leachate recirculation project. Presented at the Modern Double-Lined Landfill Management Seminar, New York State Department of Environmental Conservation, Saratoga Springs, NY (March 2-4).
5. U.S. Environmental Protection Agency. 1993. Leachate recirculation for remedial action at MSW landfills, draft final report. Risk Reduction Engineering Laboratory, Cincinnati, OH.

6. Reinhart, D.R., and D.A. Carson. 1993. Full-scale application of landfill bioreactor technology. In: Proceedings of the 31st Annual Solid Waste Exposition of the Solid Waste Association of North America, San Jose, CA (August 2-5).
7. U.S. Environmental Protection Agency. 1993. Evaluation of the Collier County, Florida, landfill mining demonstration. EPA/600/R-93/163. Risk Reduction Engineering Laboratory, Cincinnati, OH.

# **Landfill Bioreactors: Historical Perspective, Fundamental Principles, and New Horizons in Design and Operations**

---

Frederick G. Pohland

Department of Civil and Environmental Engineering, University of Pittsburgh,  
Pittsburgh, Pennsylvania

---

## **Abstract**

Landfill bioreactors have emerged as new generation methods of managing solid wastes. Their operational principles have been demonstrated in the laboratory, on pilot scale, and at field installations. By incorporating onsite containment with liners, covers, and caps; integrating waste receipt and disposal operations into dedicated cells or compartments; managing leachate and gas; and providing closure and postclosure maintenance sites, they have become engineered reactor systems for accelerated biochemical waste conversion and stabilization, facilitated by controlled leachate generation, collection, in situ recirculation, and ultimate disposal. Compared with conventional sanitary landfills, landfill bioreactors provide more rapid, complete, and predictable conversion of readily degradable solid waste constituents, thereby enhancing the potential for gas recovery and utilization, diminishing management time and process uncertainty, and reducing the potential for adverse health and environmental impacts and attendant liabilities, while increasing resource recovery and site reutilization opportunities.

By tracing the evolution of landfill bioreactors since their inception over two decades ago, the central role of moisture in promoting microbially mediated waste conversion and facilitating substrate availability and transport is abundantly evident. Indeed, deliberate moisture management provides an opportunity to initiate and regulate the sequential anaerobic phases of acid and methane formation, crucial to organic waste conversion and environmental conditioning in controlled bioreactor landfills. This fundamental knowledge is necessary for prospective development and application of controlled bioreactor landfills for accelerating the sequential phases of waste stabilization in an unimpeded, predictable, and cost-effective fashion. Selected information demonstrating current understanding and implementation procedures is presented, together with emerging refinements and opportunities for future development.

## **Introduction**

Since its inception over two decades ago (1, 2), use of leachate containment, collection, and recirculation has led to the transformation of sanitary landfills into controlled bioreactor systems. Hence, landfill bioreactors are now universally recognized as dynamic, microbially mediated, and operationally influenced waste conversion systems, optimized to promote synergism between the inherent microbial consortia, and controlled to accelerate the

---

intensity and duration of these phases, established by both pilot-scale (3) and full-scale (4) investigations, are primarily reflected by characteristic changes in leachate and gas generation patterns (5). Accordingly, as moisture accumulates and becomes more uniformly distributed with leachate recirculation, waste stabilization progresses sequentially through initial, transition, acid formation, methane fermentation, and final maturation phases, or Phases I through V highlighted in Figure 1 for a typical landfill bioreactor compartment.

During the sequential phases of landfill stabilization, reactive organic and inorganic waste constituents are released and transformed, with the former often conditioning the chemical environment for the simultaneous attenuation of the latter, and for the more resistant and otherwise recalcitrant constituents as well. Therefore, the readily degradable and reactive organic waste constituents can be effectively and predictably converted to intermediates and end-products, principally by initial hydrolysis of complex organic materials to intermediate substrates supportive of acidogenesis, and the subsequent utilization of the products of acidogenesis as precursors to the formation of gas during methanogenesis. The concomitant microbially mediated evolution of hydrogen, reduction of nitrates and sulfates, and contribution of these processes to the overall environmental conditioning are also significant in making attenuation of other constituents possible. In reality, these transformations are similar to those occurring in separate anaerobic processes for the treatment of industrial and municipal wastes (6) but are more evident in landfills because of the massive batch-type substrate loadings and the relatively longer residence times. This latter temporal feature also promotes opportunities for microbial adaptation, syntrophy, and the associated transformation and detoxification of codisposed hazardous waste constituents. Collectively, such understanding has led to design and operational innovations that separate the controlled landfill bioreactor from its sanitary landfill counterpart.

#### *Landfill Bioreactor Attenuating Mechanisms*

The unusual capacity to effectively attenuate (i.e., transform) a heterogeneous mixture of waste constituents to lessen their potential adverse impacts after disposal and release into the leachate and gas transport phases is one of the most compelling advantages of landfill bioreactor systems. In the absence of impeding or inhibiting influences, this capacity is driven by the sufficiency of moisture and nutrients and consummated by the association of biotic and abiotic processes operative throughout the previously defined phases of stabilization. Accordingly, attenuation applies not only to readily available and nonhazardous constituents (see Figure 1) but also to toxic heavy metals and organic pollutants either unintentionally or intentionally codisposed with the input waste (7, 8).

With regard to the latter waste constituents, the mobility of landfilled heavy metals is largely determined by the intrinsic properties of the leachate in terms of species solubility equilibria and the associated potential for precipitation, complexation, and immobilization. Hence, early in the waste stabilization sequence, low pH prevails, many of the metals are mobilized, and the leachate becomes more aggressive and potentially threatening. The ensuing development, however, of anaerobic reducing conditions with hydrogen production and lowering oxidation-reduction potentials is conducive to microbially mediated reduction of sulfates to sulfides, which form very sparingly soluble precipitates with many heavy metals.



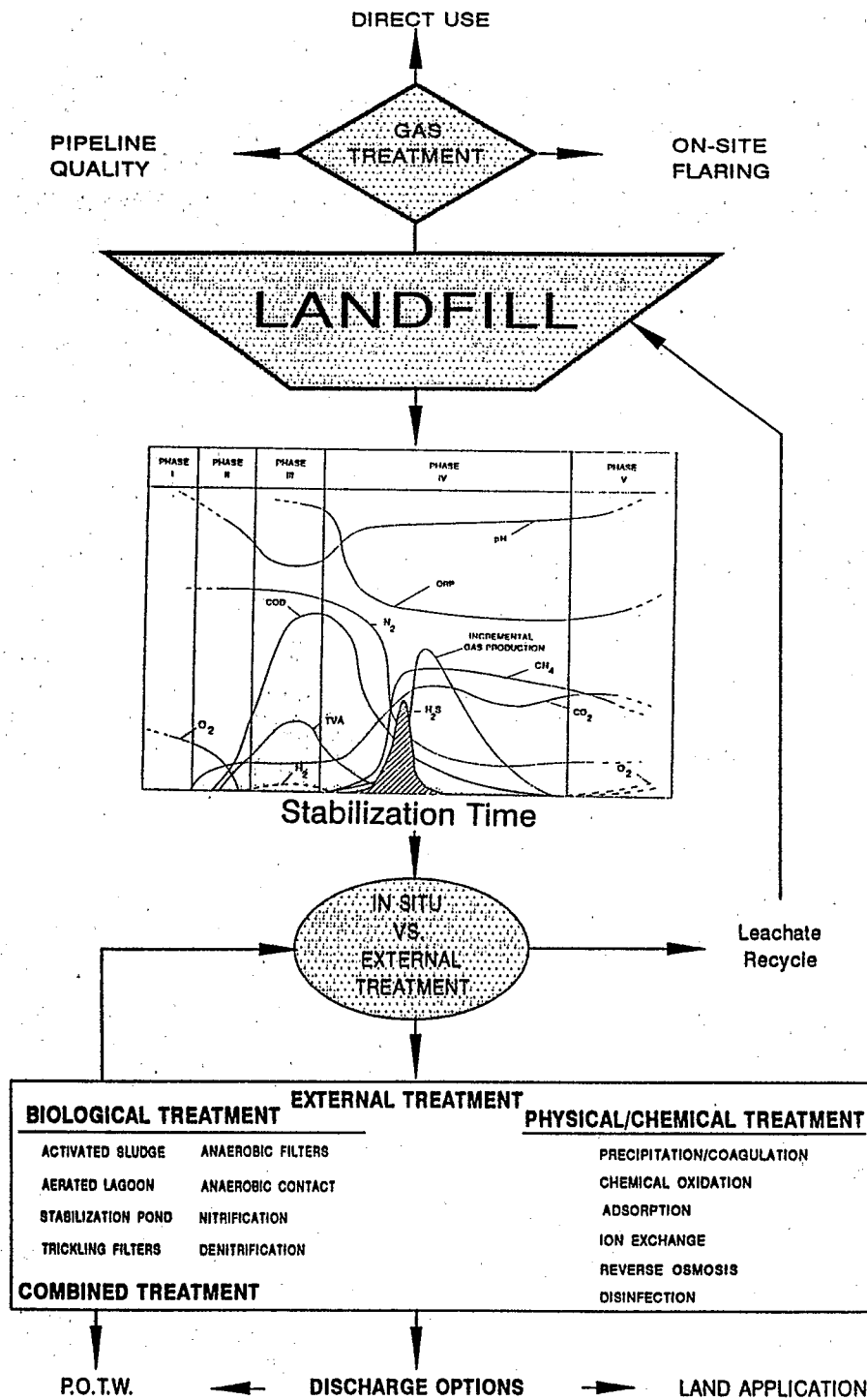

**Figure 1. Landfill bioreactor management options.**

Even under intentional codisposal scenarios as with heavy metal sludges, opportunities for attenuation are prevalent during both acidogenic and methanogenic periods, as depicted in

Figure 2. Accordingly, formation and precipitation of iron, cadmium, nickel, zinc, and lead sulfides can reduce leachate concentrations of these metals to almost undetectable levels. Therefore, the more rapid onset and greater intensity of reducing conditions, formation of sulfides, and resultant attenuation of otherwise potentially inhibiting and toxic heavy metals are important mechanisms in landfill bioreactors that are not as developed or effective in more traditional landfills, where washout occurs and leachate accumulations are routinely removed and subjected to expensive external treatment. These and other heterogeneous physical-chemical mechanisms, including physical adsorption, ion exchange, mechanical filtration, and localized containment in transiently stagnant void volumes or pooled liquid, further advance the efficacy of landfill with leachate recycle for controlled bioreactor operations.

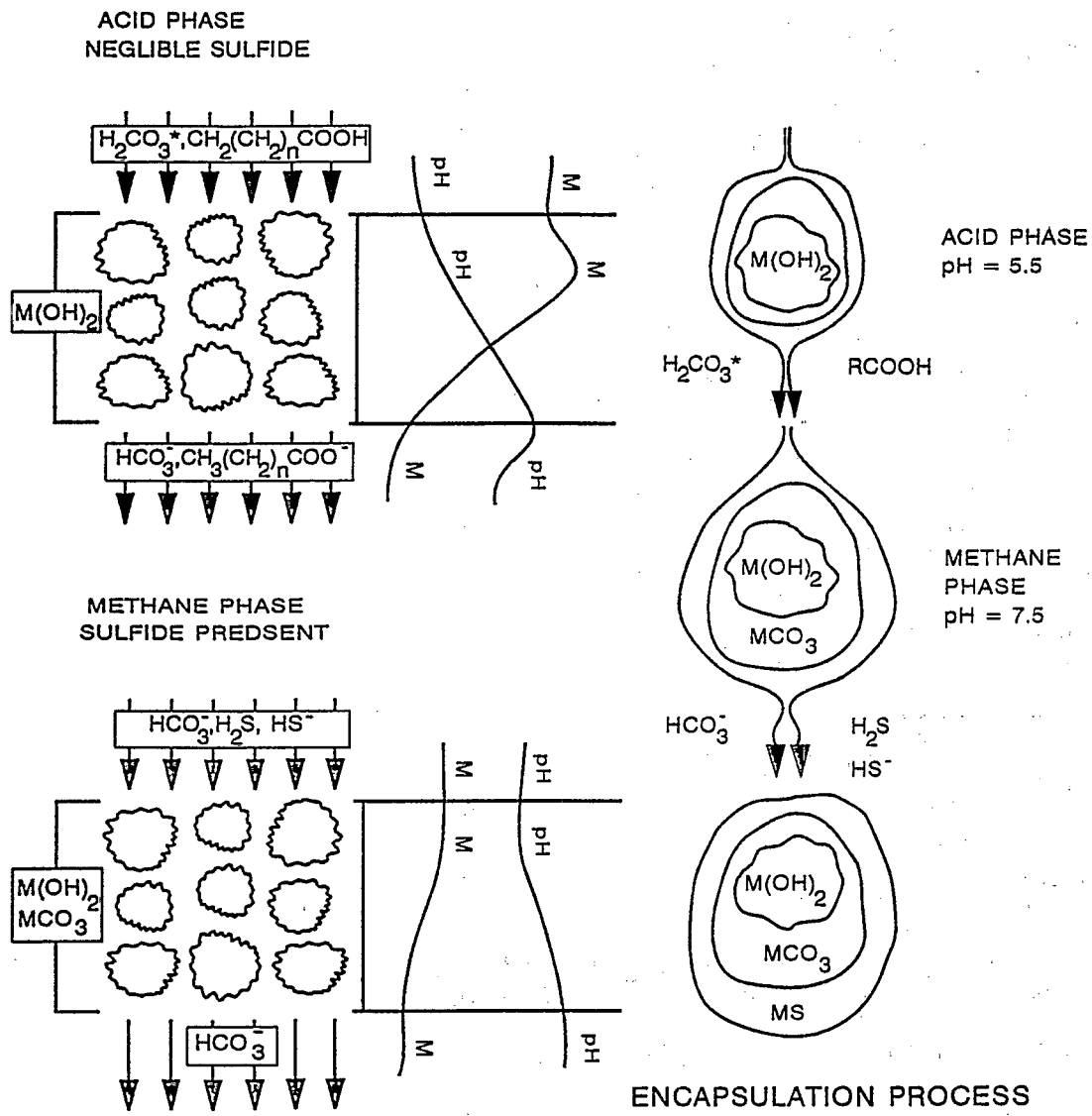

Figure 2. Heavy metal attenuation mechanisms during landfill stabilization.

The attenuation capacity of landfill bioreactors is equally dramatic for toxic organic compounds. This is largely due to in situ microbial acclimation and transformation afforded by the extended hydraulic residence times, and the continual and more complete contact between the active biomass and target substrates and essential nutrients provided by leachate recirculation. Bioremediation with reductive dehalogenation is a prime example in this regard (see Figures 1 and 3), although gas and leachate transport and interception, sorptive matrix capture, and complexation are also operative (8, 9). Hence, the advantages of leachate and gas control, integral to a proper functioning landfill bioreactor system, are again evident.

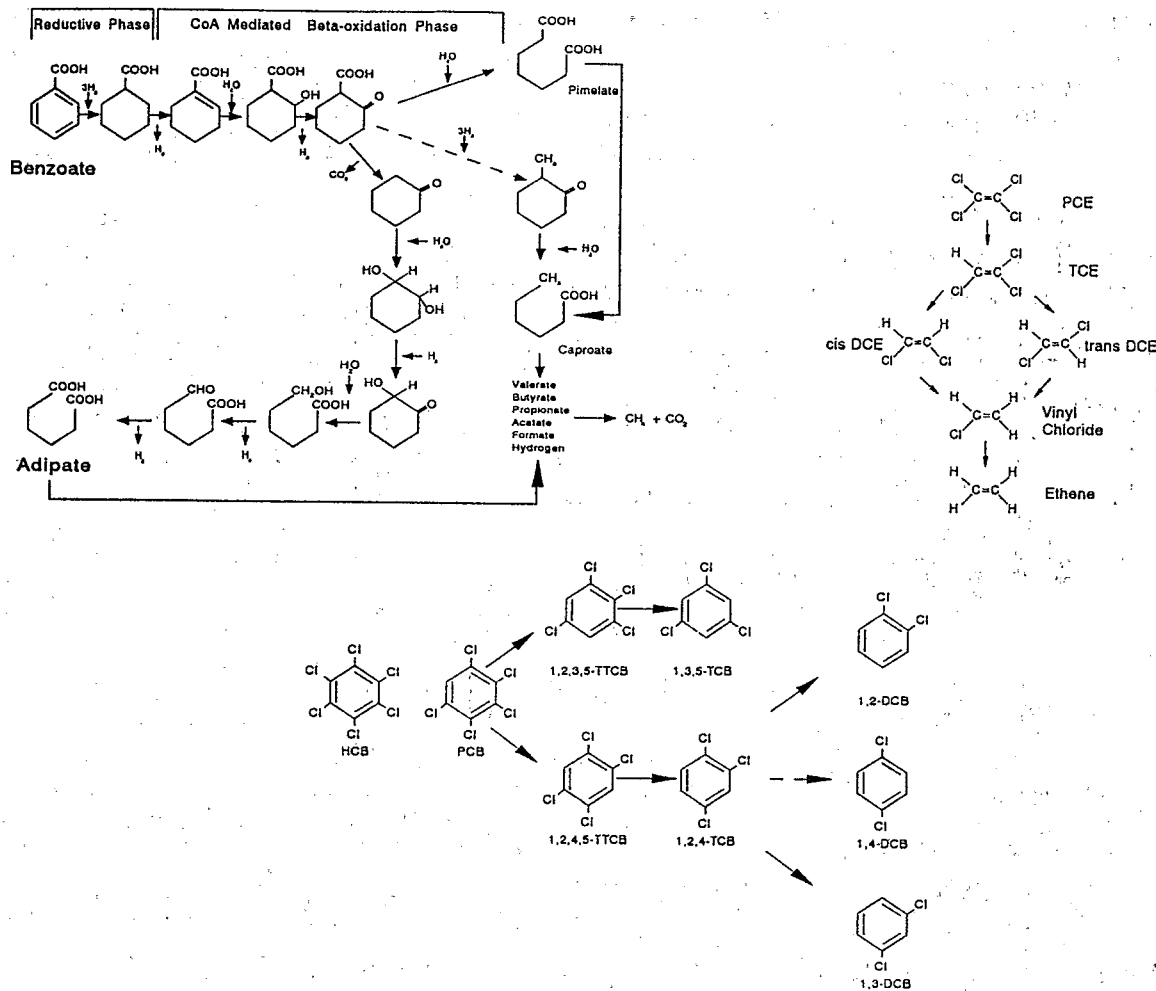

Figure 3. Inferred pathways of anaerobic dehalogenation of benzate, tetrachloroethene (PCE), and hexachlorabenzene (HCB) (adapted from 25-27)

#### Landfill Bioreactor Implementation Strategies

To take advantage of the enhanced attenuating capacity of landfill bioreactors, they must be conceived and managed in a prospective manner, linking basic understanding of the inherent

microbially mediated and physical-chemical reaction processes with their temporal and spatial domains throughout the design, construction, operation, and closure/postclosure periods. Therefore, the planned conduct of operational sequences (i.e., waste processing/loading, intermediate cover, leachate and gas management, closure, monitoring, etc.) after site selection and preparation is as important as control of the stabilization sequences. Without such an approach, successful operation of the landfill complex as a bioreactor system will be curtailed.

To accommodate the requirements for a successful implementation strategy, it is necessary to maintain operational control not only over the waste substrate but also the leachate and gases arising from its transformation. Realities of operational procedures must be coordinated to facilitate leachate and gas management, utilization, and/or ultimate disposal. Conventional landfill construction in discrete cells and lifts with liners, drains, gas vents, leak detection systems, and intermediate and final covers must be modified for the leachate recirculation and gas management systems necessary to ensure optimum bioreactor operations and control.

With leachate recirculation, the temporal domain of each phase depicted in Figure 1 is compressed, and accelerated stabilization of the readily degradable waste fractions leads to a stronger, more aggressive leachate during acid formation than is encountered in traditional landfills without leachate recirculation but associated requirements for periodic leachate removal and external treatment, and a higher gas production and weaker leachate during methane formation. Hence, stabilization is accomplished in situ with a leachate recirculation strategy, whereas much of the stabilization (and potential gas production) associated with landfills without leachate recirculation is accomplished externally. In either case, some form of posttreatment is necessary prior to ultimate disposal, depending on remaining constituents (e.g., ammonia, salts), local circumstances, and regulatory requirements. This again emphasizes a distinguishing feature between the two leachate management options (i.e., the benefit of more rapid and forgiving in situ treatment versus the requirement for extended and more challenging and costly ex situ leachate treatment).

In view of these considerations, and recognizing that available moisture will promote transformation of the degradable waste constituents as each landfill cell and lift is filled and covered, facilities for leachate and gas management should be installed concomitantly with the landfill development to access, capture, and control the gas produced and to permit scheduled recirculation of the leachate as it accumulates and drains into the collection system. Although passive gas venting with trenches and/or wells could serve as temporary gas management systems, active control is preferred, particularly as the production of principal and trace gases increases with accelerated stabilization, and possibilities for beneficial recovery are enhanced. Likewise, leachate recirculation systems must be conceived to be flexible in order to effectively respond to routine monitoring results and to distribute leachate incrementally with a schedule in concert with the progress of stabilization. This can be accomplished either within discrete cell(s) areas or in companion areas, i.e., lower recirculation rates during the early acidogenic phase and increasing rates during the active methanogenic phase to an optimal level or to a level needed for beneficial recovery and to meet customer needs. The progress toward maturation will proceed essentially in parallel with loading rates, creating different spatially and temporally distributed stabilization patterns along the stabilization phase continuum. Older areas may provide startup seeding for newer areas, and the leachate from newer areas can be diverted to older, stabilized areas serving as

dedicated methanogenic zones or compartments. The total quantity of leachate allowed to accumulate should be restricted to that amount required to effectively operate the various compartments of the bioreactor landfill system, to accommodate any regulatory restrictions, and to minimize the eventual residual quantity requiring removal and ultimate disposal, with or without posttreatment, after active methanogenic is essentially complete.

Any posttreatment requirements would be site-specific but either could be delayed by utilizing some of the stabilized leachate from one landfill section to initiate recirculation and provide treatment in another or could include any or combinations of the established treatment/disposal options indicated in Figure 1. Such posttreatment requirements would be less and simplified for a landfill bioreactor than for a landfill without recirculation because the total quantity of leachate generated and its quality after completion of accelerated in situ stabilization (Phase IV) would be known sooner and more reliably. Moreover, removal of the accumulated leachate from the stabilized landfill system at the end of this stage basically deprives it of the optimal moisture and essential nutrient distribution required for continued active microbially mediated conversion of less reactive waste constituents and thereby converts the bioreactor system into a condition of relative dormancy. This latter consequence is beneficial in establishing postclosure care requirements, including extent and frequency of monitoring and maintenance, which could introduce considerable cost savings opportunities.

### **Status of Landfill Bioreactors**

Despite their merits and relatively long-term development, there are few (but a growing number of) full-scale, prospectively planned, designed, and installed bioreactor landfills operated with controlled leachate recirculation. Contrary, however, to previous reluctance to intentionally introduce moisture into landfills and perceptions of adverse effects, many landfills have utilized some type of leachate recirculation if only to lessen the problems and costs associated with intermittent leachate generation and treatment during filling operations. As of 1986, there were over 200 municipal landfills in the United States employing some form of leachate recirculation, with almost a similar number being planned (10). Some landfills have had operating leachate recirculation systems for over a decade, including landfills receiving both municipal (11, 12) and industrial (13) solid wastes. Both large pilot-scale (14) and full-scale (15) investigations are ongoing, particularly focused on investigating options for containment and configuration/operation of leachate and gas management systems, and more are being planned and constructed. Collectively, these efforts have promoted a variety of design and operational changes directed at overcoming problems created by the less formalized approaches of the past, particularly with respect to leachate recirculation and gas extraction systems, and have promoted regulatory allowance of landfill bioreactor systems at both national and local levels.

### *Design Elements*

The essential elements of landfill bioreactors include the containment systems, compartmentalization, and integrated gas management and leachate collection, storage, and recirculation systems. Although a standard design approach to these has not yet been established, more experience and guidance is becoming available (16). General consensus

---

now suggests that dual liner systems affording both containment and leak detection are preferred, with cells placed in lifts separated by intermediate permeable cover as filling operations proceed. Leachate collection and distribution are accomplished with underdrains, sump pumps, and interconnected wells and/or trenches, often installed by segments and also serving as temporary gas venting systems as each lift is added. The final construction of each landfill bioreactor system may also include surfacial leachate distributors placed below the final cap or cover, and an active gas control/utilization system.

An example configuration is indicated in Figure 4, a Delaware Solid Waste Authority landfill designed to receive municipal refuse over a period of about 5 years. In this case, the soil used for daily/intermediate cover will consume about 19 percent of the landfill volume, with a total waste disposal capacity of about 932,000 m<sup>3</sup> at an in-place density of 680 kg/m<sup>3</sup>. Passive gas vents placed at intervals of elevation also serve as temporary leachate recirculation wells during construction. The design, however, for the main leachate recirculation system after closure includes three injection wells and two surfacial leachate recirculation fields. The wells extend from the top of the landfill to a depth about 5 m above the bottom liner, with interconnecting gravel collars between main lift sections, and installed to access each of the four integrated fill areas. The leachate recirculation field also includes cascade-type distributors strategically located at the surface below the final cap and above the deepest portions of the landfill.

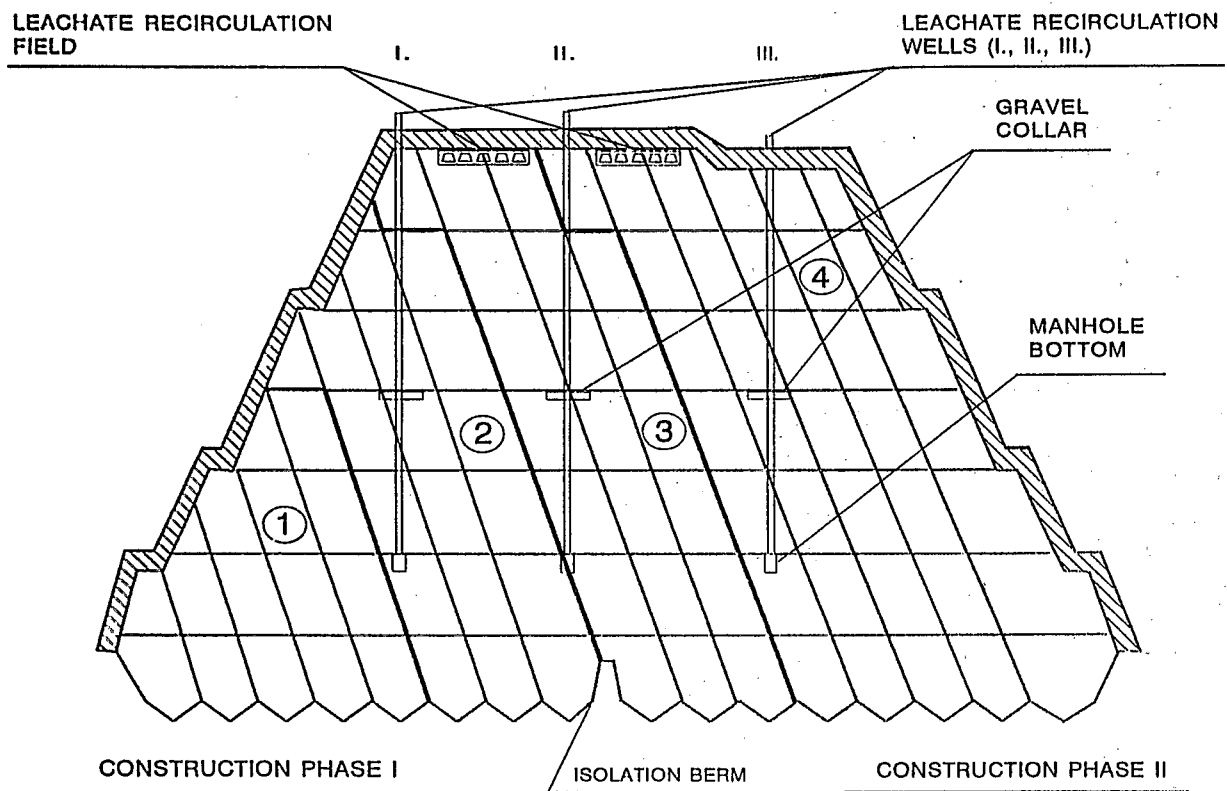

Figure 4. Cross-section of field-scale landfill bioreactor.

The passive gas vents, serving as temporary leachate recirculation wells, are designed to be installed as the filling operations proceed. Consisting of 1.22-m diameter, perforated, precast concrete manhole sections filled with aggregate and containing two perforated 10-cm polyvinyl chloride (PVC) (Schedule 60) pipes to serve as leachate recharge conduits and level sensors, respectively, these and the other passive vents are to be converted to active gas control systems at closure. The three main leachate recirculation wells are to be similarly constructed but with two two-pipe recharge/level sensor systems for delivery of leachate between the two designated operational depths of the landfill. Likewise, the two leachate recirculation fields below the final cap are to consist of two laterals each, constructed of manufactured distributors embedded in 15 cm of gravel and covered by a 15-cm bedding layer of clean sand, similar to that to be placed above the leveling course of intermediate cover used in the capping system construction.

Leachate has been designed to be collected in 15-cm perforated high density polyethylene (HDPE) pipe embedded in ballast covered by a geotextile envelope and placed in trenches located at uniform intervals across the sloped bottom of the landfill. The trenches are otherwise filled with a 61-cm protective layer of sand that separates the primary membrane liner (60-mil HDPE or 36-mil HYPALON) from the solid waste above, and the 30 cm of drainage sand composing a secondary leachate detection system below. This detection system also contains a similar leachate collection system (pipe and gravel/geotextile) and is located immediately above a secondary membrane (HDPE or HYPALON) liner and a bentonite/geotextile composite liner resting on the compacted subgrade. The leachate collection laterals and headers are connected to cleanouts extending at an angle through the side cover system near the toe of the landfill. Leachate is directed by gravity to sumps where it may be pumped for recirculation or sent to storage.

### *Design Bases*

The location and sizing of leachate and gas management facilities can be based upon anticipated leachate and gas generation and transport rates, modeled in accordance with the principles of unsaturated flow through porous media (17). The potential for leachate formation can be assessed using a moisture balance and selecting the type and configuration of appurtenances needed for collection, recirculation, and/or storage and their operational frequencies. Similarly, gas production can be estimated, and extraction rates can be determined on the basis of convective flow and/or diffusion. The resultant zones of influence of the leachate or gas management systems lead to the choice of type, size, and configuration of appurtenances necessary to provide operational control. This choice is largely a matter of designer preference or regulation, and various configurations can be used. Those systems described herein, however, tend to be more frequently employed, with leachate collection and recirculation wells and trenches being more variably spaced and contingent on site-specific requirements, whereas passive and active gas extraction wells and/or trenches are ordinarily spaced 8 to 15 m and 30 to 60 m apart, respectively.

*Economic Ramifications*

When assessed on the basis of economic considerations, and compared with other leachate management options as part of the onsite or offsite treatment scenarios indicated in Table 1, two general management strategies with seven plausible alternatives can be recognized, i.e., single-pass leaching associated with landfills operated without leachate recirculation, and landfill bioreactors with leachate recirculation and in situ treatment (17, 18).

The resultant cost estimates for the indicated alternatives were compared in terms of a total annual cost unit (TACU), approximating U.S. \$2,500/acre·year (approximately U.S. \$6,200/hectare·year), including both capital and operating costs. As shown in Figure 5, leachate recirculation options are currently more economically favorable compared with single-pass leaching. Moreover, if the landfill mining and recovery alternative after accelerated stabilization is selected, and an associated shorter term, postclosure care period with reduced liability is presumed, an overall annual profit (-1.0 TACU) can be realized. Accordingly, the total investment in leachate recirculation with in situ treatment could be offset by the savings associated with landfill space recovery.

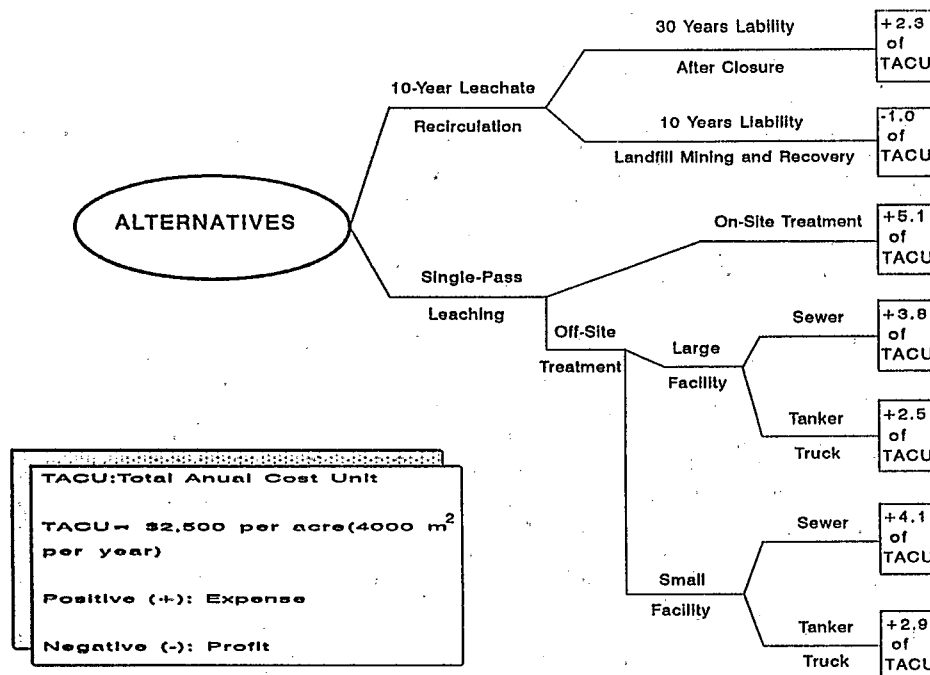

**Figure 5. Economic analysis of landfill leachate management options.**



**Table 1. Leachate Management Options Selected for Economic Assessment**

| Leachate Management Options | Alternatives  | Description   |
|-----------------------------|---------------|---|
| Leachate                    | Alternative 1 | Leachate recirculation: 5-year period of landfilling operation; leachate recirculation starts concomitantly with landfilling operations and continues for 5 years after closure (i.e., 10-year total recycling); leachate final discharge (irrigation) starts 5 years after closure and continues for 25 years (i.e., ends at Year 30 after closure); total operation, care, and liability period is 35 years.  |
| Recirculation               | Alternative 2 | Leachate recirculation: 5-year period of landfilling operation; leachate recirculation starts concomitantly with landfilling operations and continues for 5 years after closure (i.e., 10-year total recycling); leachate final discharge (irrigation) starts 5 years after closure and continues for 5 years (i.e., ends at Year 10 after closure); total operation, care, and liability is 15 years when the landfill is to be mined and reclaimed. |
| Single                      | Alternative 3 | Onsite leachate treatment, including physical, chemical, and biological processes (primary, secondary, and tertiary); simultaneous discharge of treated leachate (irrigation); liability period is 30 years after closure (i.e., total operation and care period is 35 years).  |
|                             | Alternative 4 | Offsite leachate treatment at a large wastewater treatment plant (5-mile distance) with an underground sewer system network; liability period is 30 years after closure (i.e., operation and care period is 36 years).  |
| Pass                        | Alternative 5 | Offsite leachate treatment at a large wastewater treatment plant (5-mile distance) with a tanker truck hauling system for leachate; liability period is 30 years after closure (i.e., operation and care period is 35 years).   |
| Leaching                    | Alternative 6 | Offsite leachate treatment at a small wastewater treatment plant (5-mile distance) with an underground sewer system network; liability period is 30 years after closure (i.e., operation and care period is 35 years).  |
|                             | Alternative 7 | Offsite leachate treatment at a small wastewater treatment plant (5-mile distance) with a tanker truck hauling system for leachate; liability period is 30 years after closure (i.e., operation and care period is 35 years).   |

## **Emerging Developments and New Horizons**

The state of technology of landfill bioreactors continues to evolve as more systems are conceived and installed, and associated operating data and experience are obtained. Based upon both past and present results, it is considered likely that the landfill bioreactor of today will lead to another generation of refinements that will enhance their utility as an essential part of integrated solid waste management systems even further. Moreover, the regulatory and user sectors are expected to become more influential and lead to new opportunities for discovery and innovation.

As understanding and use of bioreactor landfills become more prevalent, modification in design, construction, and operational approaches will further separate these systems from conventional landfill practices. Already on the horizons are better integrated landfilling/construction and leachate/gas management systems, with associated features and appurtenances devised to facilitate operating as well as postclosure periods, and a recognition of a concomitant need for management expertise. Issues associated with leachate and gas generation and changing quantities and qualities will trigger innovations in control, utilization, and ultimate disposal. International competition will grow and need better interfacing to influence the selection of optimal construction and operational features, including the possible integration of in situ aerobic, semiaerobic (19), anoxic, and anaerobic microbial conversion advantages into construction and operational protocols. Assurances of postclosure integrity and maintenance, and opportunities for ultimate use, possibly through mining and resources recovery, will also become more prevalent and will form the basis for promoting enabling actions in both the technical and regulatory sectors.

In addition to the principal features of a typical bioreactor landfill (see Figure 6), several recent developments will likely help shape applications in the immediate future. Beyond changes in regulatory policy and enforcement, including a requirement for operator training and certification, such new and/or emerging developments as alternative covers (20), liner and cap modifications (21, 22) in situ nitrification/denitrification with aerobic/anoxic treatment zones or gas-phase biofilters (see Figure 7), compartmentalization with dedicated methanogenic zones (see Figure 8), leachate evaporation, preprocessing for waste conditioning and materials recovery, and landfill mining and reutilization (23-25) are all on the horizon. These modifications, if implemented and/or applied to landfill bioreactor systems, may further enhance the efficacy of in situ leachate treatment by recirculation and not only alter traditional approaches to design, construction, and operation but affect the overall economics and acceptability relative to other solid waste management options.

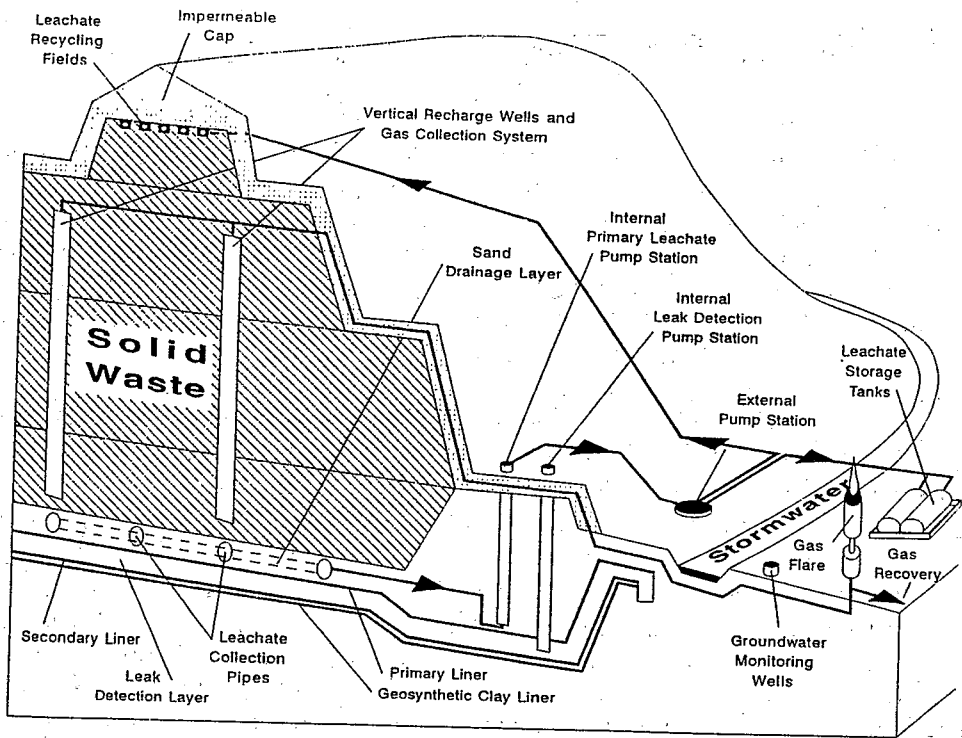

Figure 6. Representative configuration of a landfill bioreactor.

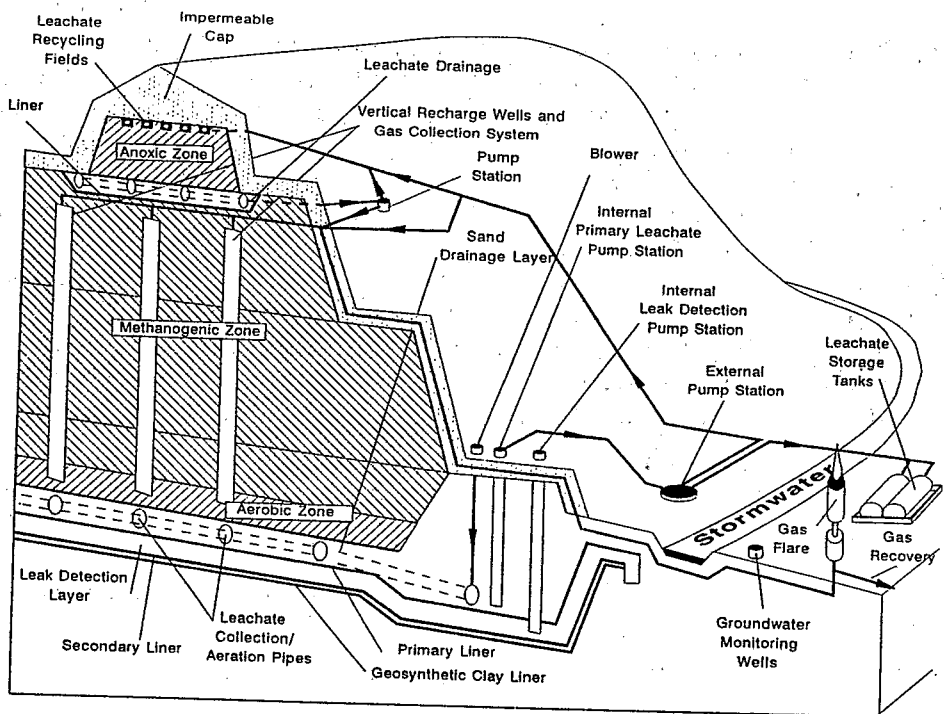
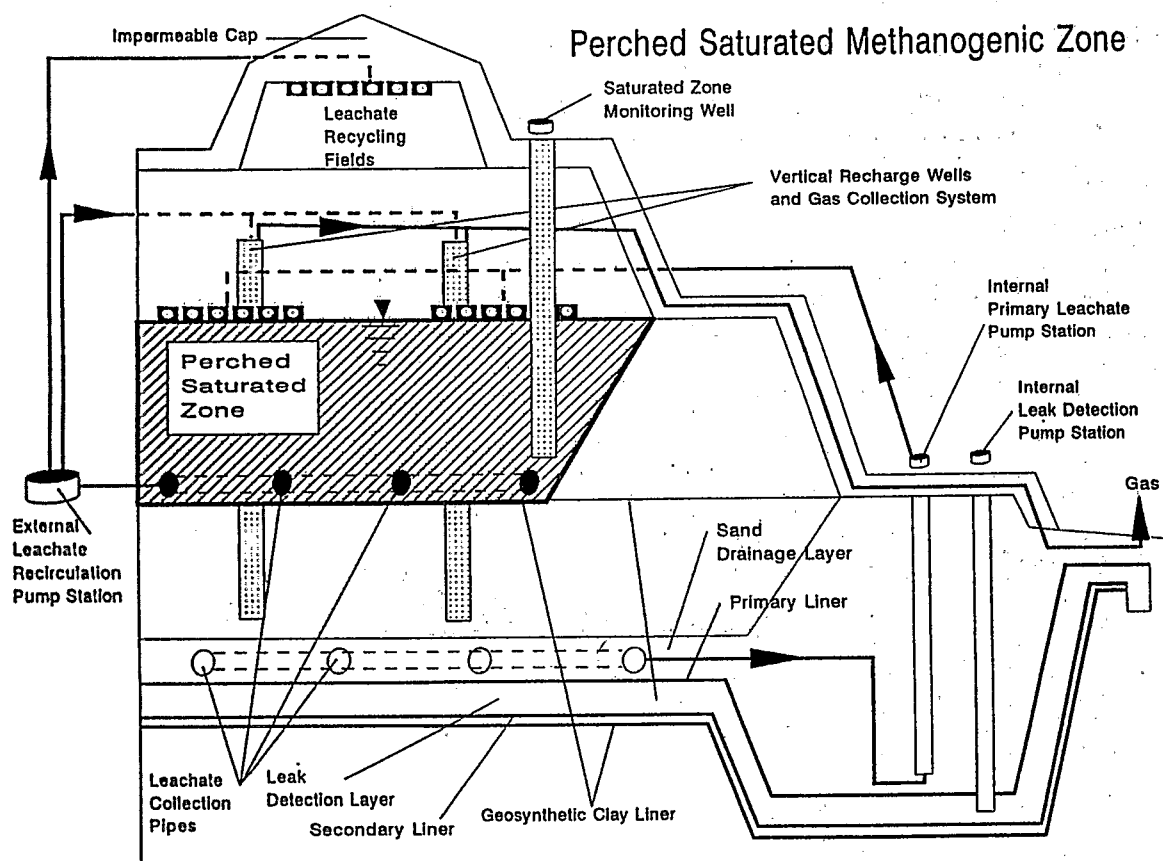

Figure 7. Modified landfill bioreactor for leachate nitrogen removal and biofiltration.



**Figure 8. Modified landfill bioreactor with dedicated methanogenic zone.**

### Summary and Conclusions

1. Bioreactor landfills with in situ leachate recirculation and treatment prior to ultimate disposal are attractive and cost-effective solid waste management options that accomplish accelerated waste stabilization in a more predictable and shorter time than required by traditional landfilling practices.
2. Accelerated stabilization and attenuation can be enhanced by prospective design, construction, and operation of landfills as controlled, microbially mediated, anaerobic reactor systems, featuring appurtenances for effective, integrated leachate and gas management.
3. The economic advantages of accelerated stabilization in landfill bioreactors with leachate recirculation can be affirmed by favorable cost comparisons with single-pass leaching and onsite or offsite leachate treatment and disposal.

4. Progress in the development and application of landfill bioreactors will be enhanced and extended by the integration of new and emerging technologies into field-scale demonstrations and by further analysis of controlled landfills that are designed and operated with leachate recirculation for accelerated stabilization and potential resource recovery and utilization.

#### References

1. Engineering Foundation Program. 1970. Application of environmental R&D on the land disposal of solid waste. Deerfield Academy, Deerfield, MA.
2. Pohland, F.G. 1975. Accelerated solid waste stabilization and leachate treatment by leachate recycle through sanitary landfills. *Prog. in Water Tech.* 7(3/4): 753-765.
3. Pohland, F.G. 1991. Fundamental principles and management strategies for landfill codisposal practices. In: *Proceedings of the Third International Landfill Symposium*, Cagliari, Italy. pp. 1445-1460.
4. Reinhart, D.R., and D. Carson. 1993. Experiences with full-scale application of landfill bioreactor technology. In: *Proceedings of the 31st Annual SWANA Solid Waste Symposium*, San Jose, CA. pp. 311-323.
5. Pohland, F.G., and S.R. Harper. 1978. Critical review and summary of leachate and gas production from landfills. NTIS PB 86240. Springfield, VA.
6. Pohland, F.G. 1992. Anaerobic treatment: Fundamental concepts, applications, and new horizons. *Design of anaerobic processes for the treatment of industrial and municipal wastes*. Technomic Publishing Company. pp. 1-40.
7. Pohland, F.G., and S.R. Harper. 1987. Retrospective evaluation of the effects of selected industrial wastes on municipal solid waste stabilization in simulated landfills. NTIS PB 87198 701/AS. Springfield, VA.
8. Pohland, F.G., W.H. Cross, J.P. Gould, and D.R. Reinhart. 1993. Behavior and assimilation of organic and inorganic priority pollutants codisposed with municipal refuse, vol. I and vol. II. NTIS PB 93222198AS. Springfield, VA.
9. Reinhart, D.R. 1989. Fate of selected organic pollutants during landfill codisposal with municipal refuse. Ph.D. Thesis, Georgia Institute of Technology, Atlanta, GA.
10. U.S. EPA. 1988. Report to Congress: Solid waste disposal in the United States, vol II. EPA/530/SW-88/011B. pp. 4-37.
11. Kilmer, K.W. 1991. Leachate recycling: An alternative landfill management technology. *Solid Waste and Power*. pp. 41-49.

12. Vasuki, N.C. 1993. Practical experiences with landfill leachate recirculation pilot and field scale units. In: Proceedings of the 31st Annual SWANA Solid Waste Symposium, San Jose, CA.
13. Merritt, C.A. 1992. Full-scale leachate recycling at an industrial landfill. In: Proceedings of the Water Environment Federation Conference, New Orleans, LA. pp. 101-112.
14. Anon. 1993. Landfill cell incorporates innovative design and leachate management. *Public Works* 124(10): 88-89.
15. Morelli, J. 1992. Leachate recirculation: Design and operation considerations. *MSW Mgmt.* 2(3): 26-36.
16. Harper, S.R. 1993. Design elements associated with leachate recirculation at new and existing landfills. In: Proceedings of the 31st Annual SWANA Solid Waste Symposium, San Jose, CA. pp. 291-309.
17. Al-Yousfi, A. 1993. Modeling of leachate and gas production and composition at sanitary landfills. Ph.D. Thesis, University of Pittsburgh, Pittsburgh, PA.
18. Pohland, F.G., and A.B. Al-Yousfi. 1995. Design and operation of landfills for optimum stabilization and biogas production. *Water Sci. and Technol.* 30(12): 117-124.
19. Matsuo, T., N. Tanaka, and K. Koyama. 1991. Stabilization mechanisms of leachate from semi-aerobic sanitary landfills of organic-rich waste. In: Proceedings of the Third International Landfill Symposium, Cagliari, Italy. pp. 875-888.
20. Pohland, F.G., and J.T. Graven. 1993. The use of alternative materials for daily cover at municipal solid waste landfills. NTIS PB 93227197. Springfield, VA.
21. Koerner, G.R., R.M. Koerner, and J.P. Martin. 1993. Field performance of leachate collection systems and design implications. In: Proceedings of the 31st Annual SWANA Solid Waste Symposium, San Jose, CA. pp. 365-380.
22. Daniel, D.E. 1993. Geosynthetic Clay Liners (GCLs) in landfill covers. In: Proceedings of the 31st Annual SWANA Solid Waste Symposium, San Jose, CA. pp. 403-431.
23. Spencer, R. 1990. Landfill space reuse. *BioCycle* 30-33.
24. Nelson, H. 1994. Landfill reclamation strategies. *BioCycle* 40-44.
25. Aquino, J.T. 1994. Landfill reclamation attracts attention—and questions. *Waste Age* 63-66.

## **Landfill Bioreactor Design and Operation: A New York State Regulatory Perspective**

---

Robert J. Phaneuf

New York State Department of Environmental Conservation, Albany, New York

---

### **Abstract**

The modern landfill constructed and operated in accordance with New York State's solid waste management regulations, 6 NYCRR Part 360 (Part 360), is proving to be an environmentally sound method of solid waste disposal. The data being collected associated with the operational efficiency of these new containment systems substantiate the fact that the double composite liner system of a properly operated landfill provides adequate protection to ground-water quality through effective leachate accountability. From a review of the operation plans that are being submitted for these new landfills, however, we obviously are still operating these highly efficient containment systems the same way that we have operated the unlined landfills of the past.

The concept of using the modern lined landfill as a waste treatment unit (bioreactor) is a theory that New York State encourages in an effort to address the issue of the "dry tomb" method of waste disposal. This is one of the major complaints tabled by opposition groups during the siting process of new landfills. Their concerns typically characterize the undecomposed solid waste mass in the landfill as being a sort of "ticking time bomb" that would explode at some future date, likely years after landfill closure, when the man-made environmental containment system of the landfill begins to break down. The bioreactor concept, if conducted within a modern landfill's environmental containment system and with proper attention given to operational performance monitoring and controls, promotes enhanced waste mass decomposition and thus reduces the long-term pollution potential of the landfill. The secondary benefits associated with operation of a landfill as a bioreactor include optimized landfill operations via conservation of valuable air space and the associated benefit of conservation of land resources. These benefits should encourage modern landfill operators to modernize landfill operations in order to minimize their facilities' long-term pollution potential.

During early spring of 1992, the New York State Department of Environmental Conservation's Division of Solid Waste initiated a rule-making revision process to revise Part 360 to comply with Federal Municipal Solid Waste Landfill Regulations, 40 CFR Part 258, under Subtitle D of the Resource Conservation and Recovery Act (RCRA). As part of this rule-making process, the Division attempted to modify the regulations so as not to stymie the modernization of future landfill operations. The October 9, 1993, version of Part 360 was revised to include an acceptable threshold relative to liner system performance for double-lined landfills along with the "passive" requirement for new lined landfill operations to address the concept of using the landfill as a waste bioreactor. One goal of this rule-making effort was to develop a regulatory

---

framework that is not only flexible but also encourages environmentally sound, active landfill management operations.

### What the Regulations Say

During the rule-making initiative, the Division determined that the best way to promote the concept of what the Division termed "active landfill management techniques" (including utilization of the landfill as a bioreactor) would be to require that the landfill operation and maintenance manual be developed to address these modernized operational practices for each new landfill. Specifically, subdivision 360-2.9(a) of the regulations states:

A general description shall be provided of the landfill's overall operation, stipulating how this facility will be operated in an environmentally sound and resource conscious manner. Owners/operators of all new or expanded landfills which have a department approved liner and leachate collection and removal system are encouraged to utilize operational methods which conserve natural resources through alternative daily cover materials, contingent upon demonstration of compliance with all applicable provisions of this Part. Active landfill management techniques to encourage rapid waste mass stabilization and alternative energy resource production and enhanced landfill gas emission collection systems are encouraged and should be addressed in the landfill's engineering report and in the operation and maintenance manual.

It is the intent of the Division to "passively" promote active landfill management practices, in essence allowing for modernized landfill operational methods to be voluntarily pursued without imposing a regulatory burden or hurdle for facility owners to overcome. The Division realizes that a conservative double composite liner system, as required by the state's solid waste management regulations, is necessary to ensure that ground-water resources will be protected (see Figure 1).

Although just prescribing the minimum liner system in and of itself affords only a part of the necessary assurances toward protecting ground-water resources, the remaining assurance of true leachate accountability involves the process of routine monitoring of leachate production and collection. The Division stresses that it is necessary to quantitatively monitor a landfill liner system's integrity via performance monitoring of the landfill's leachate generation rate along with the landfill's upper liner leakage rates. The landfill operator can use these data as a barometer to measure the overall performance of the landfill operation with respect to leachate accountability. Upon review of the Division's facility files on the 31 active double-lined landfills in the state, it is apparent that modern double-lined landfills pose little or no immediate threat to ground-water resources based upon data from routine liner system integrity monitoring. Figures 2 through 5 summarize some of the typical liner system performance data and leachate generation data that are on file for a few of the active double-lined landfills around the state. At first glance, the data appear to be somewhat erratic. Both landfills 2 and 4 represent new landfills, however, and the increased secondary leachate collection and removal system flow data are actually caused by the initial placement of waste into these double-composite-lined landfills (modeling the effect of consolidation water on the



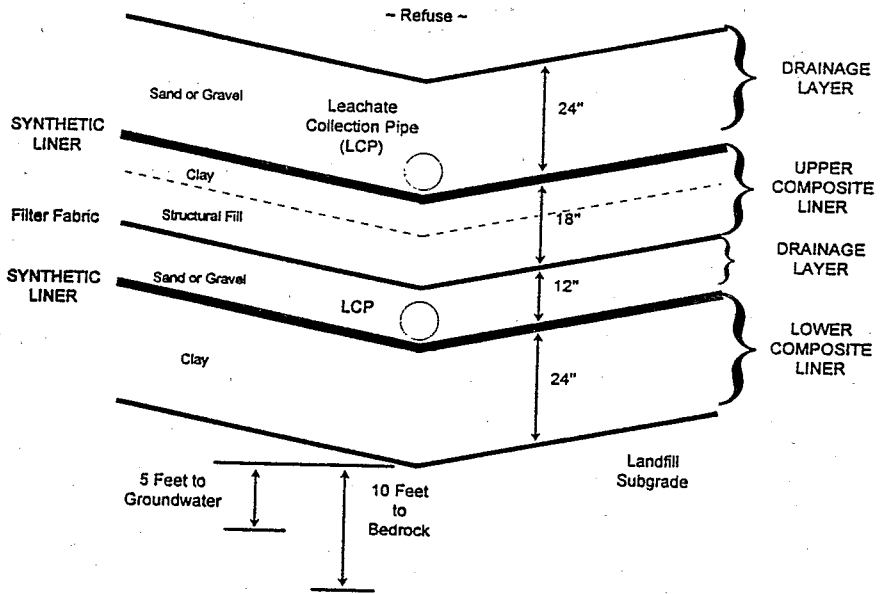

6 NYCRR Part 360-2 Landfills

Figure 1. Anatomy of the double composite liner system required for all municipal solid waste landfills in New York State.

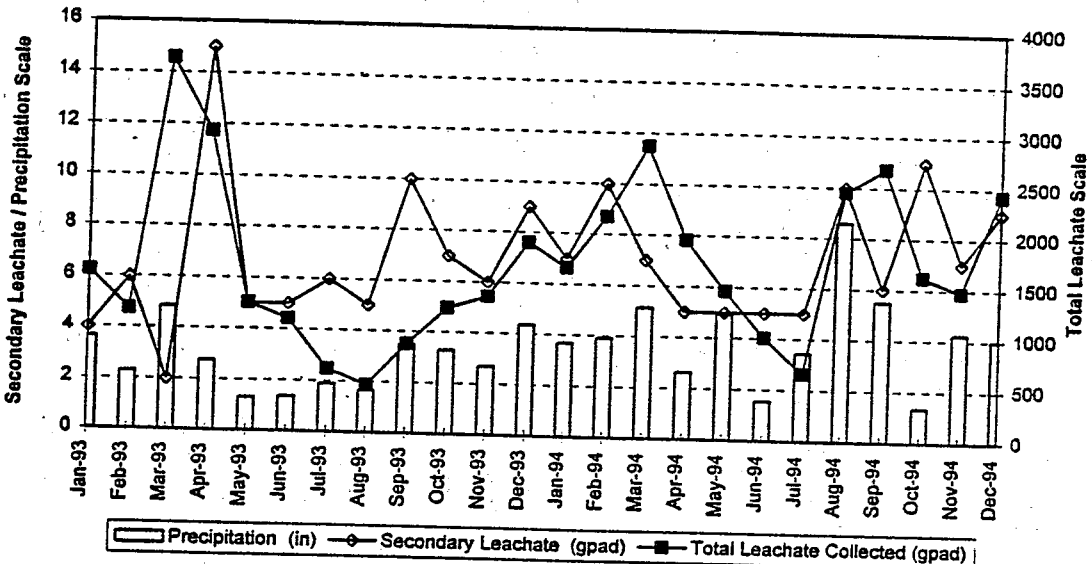

Figure 2. Landfill 1: Waste first accepted in September 1990.

upper liner leakage rate data). Landfill 1 represents a landfill that has been in operation since 1990 and quantitatively shows leachate flow data over a period of 2 years without a problem. Landfill 3's data pinpointed a pump problem during the spring of 1994. This problem would have likely gone undetected if the landfill's operator had not routinely monitored leachate and liner leakage rate flow data. Thus, one can better understand or appreciate how these easily attainable data can be used to assess overall landfill performance.

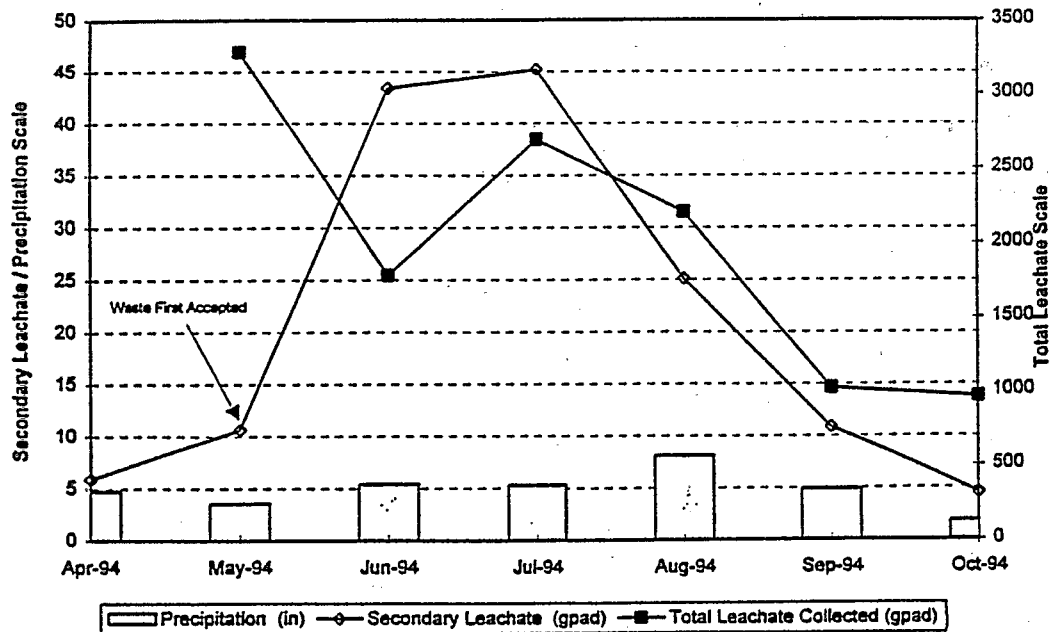

Figure 3. Landfill 2: Increased consolidation liquid during startup.

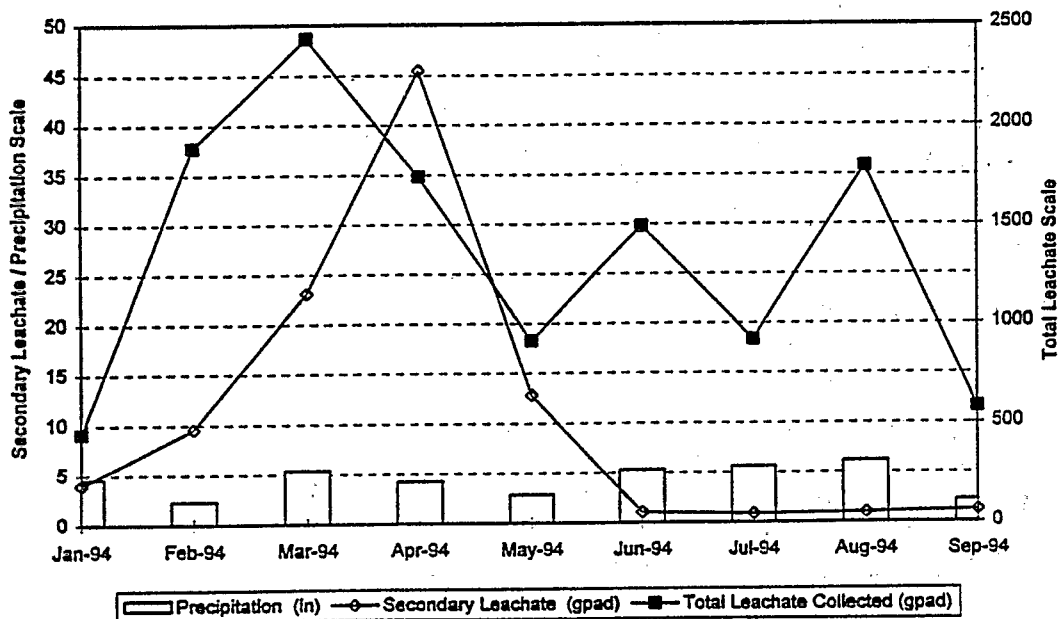

Figure 4. Landfill 3: Pump problems experienced during spring 1994.

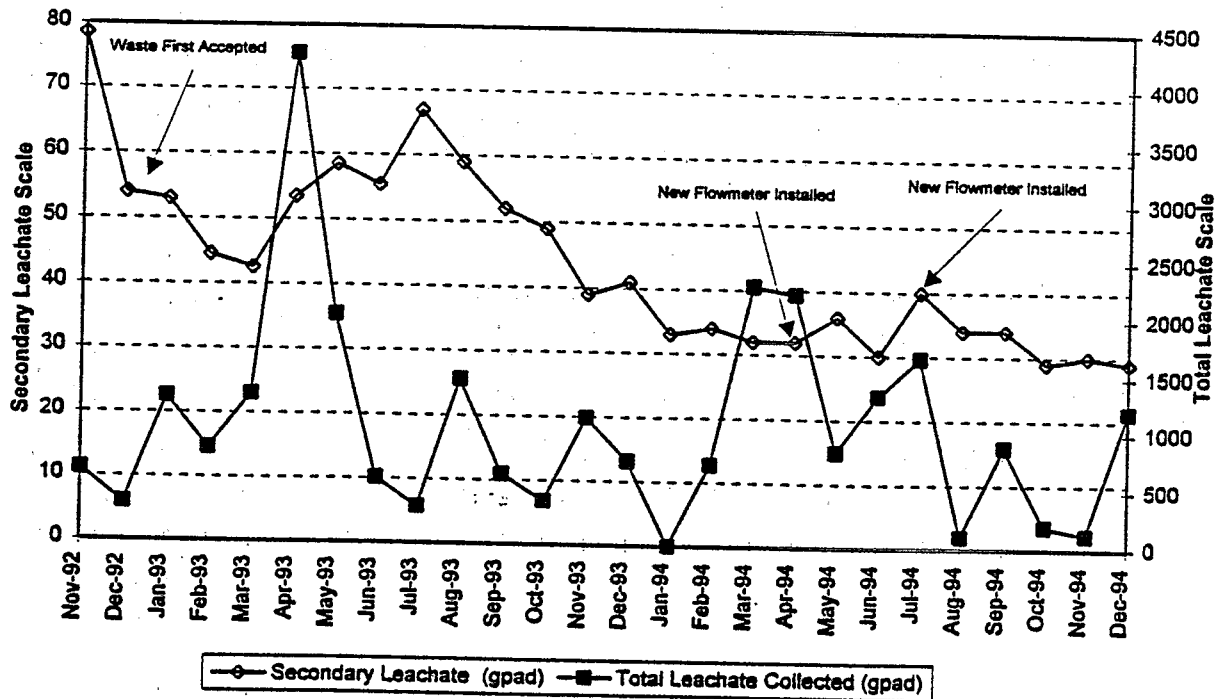

Figure 5. Landfill 4: Increased consolidation liquid during startup.

If this routine assessment of overall leachate accountability is found to be acceptable (Part 360 requires that the primary [upper] liner leakage rate for a double-lined landfill not exceed 20 gallons per acre per day [gpads] on a 30-day average), then modified operational methods used to promote enhanced waste mass degradation can be undertaken. Leachate accountability is of primary importance for ensuring that ground-water resources are adequately protected and that the landfill's liner system is functioning as designed. It is equally important, however, to advance the new concepts of "modern landfill operation" within a conservatively designed containment system, which will not only minimize the long-term risk of the landfill but will also allow for optimized operation of these new solid waste disposal facilities. Some of these new landfill operational concepts, and the prescribed benefits, are highlighted below:

- Leachate recirculation, enhancement of: results in waste mass biostabilization, waste mass densification via improved decomposition, and enhanced landfill-derived energy production through improved landfill gas production.
- Alternative daily cover materials (ADCMS): conserve natural resources and valuable air space.
- Improved leachate and gas removal and collection system designs within the internal waste mass: enhance ability to achieve more rapid waste mass biostabilization and increase the economic viability of methane gas recovery systems.

- Improved surface water runoff and runoff controls within the lined landfill: minimize leachate generation and reduce leachate treatment costs.
- Deferred placement of final cover at the properly operating double-lined landfill: better facilitates waste mass biostabilization and minimizes long-term postclosure maintenance and associated costs.

The ability to implement these new operational and closure concepts under the current regulatory framework of the state's regulations, Part 360, will be further addressed. Where applicable, the regulatory perspective regarding these operational concepts will also be discussed. Modifications to operational practices at the modern landfill can be authorized, providing it can be demonstrated that all appropriate regulatory requirements are adhered to. Many of these operational concepts being pursued by facility owners are not only based on conserving valuable air space but are also based on the fact that many of these concepts will help to conserve our natural resources and provide enhanced environmental protection as well.

#### *Leachate Recirculation/Rapid Waste Mass Biostabilization Concepts*

One typical complaint or argument against land disposal methodologies is that, even with the new highly efficient landfill liner systems and impervious final covers that landfills use, we are essentially only "entombing" our wastes. Our modern containment system also has been characterized, in nontechnical terms, as nothing more than a "hermetically sealed chicken pot-pie." This argument then is used to promote the concept of the modern landfill as a "ticking time bomb" on the premise that the liner and cover systems will not last forever. Therefore, the landfill that contains today's waste will become tomorrow's threat to the environment. These are good arguments, but they are usually made blind to the fact that new landfills with adequate leachate accountability will allow for a number of open dumps in an area to be properly closed, thus mitigating today's impacts on ground-water quality from the many unlined landfills still in existence throughout the state.

The point of concern over the long-term pollution potential of waste that is "entombed" in a modern landfill is a logical one. Much research on bench-scale testing has been conducted to study methods to actively promote waste mass decomposition and biostabilization in the landfill environment. In essence, the ability to use the landfill during its active life as a large waste biodigester has been expanded. The concept behind this is the ability to reduce the long-term pollution potential of a landfill's waste mass by rendering it into a stable condition within the timeframe of the landfill's operational life and postclosure period.

A frequently studied technology along this vein is the concept of recirculating leachate through the waste mass as a catalyst to promote active waste decomposition. In the past, without landfills being properly lined, there was a strong regulatory prohibition to any concept that would induce an additional hydraulic loading to the waste mass. This regulatory stance was taken because the impact of landfill leachate on ground-water quality is a function of the amount of leachate generated by the landfill and the amount of leachate that leaks into the ground water from either an unlined or improperly lined landfill.

The advent of the double-lined landfill with its designed ability to easily and quickly assess primary liner performance from a leakage standpoint and to establish that a particular landfill has an acceptable level of leachate accountability allowed the Division to contingently entertain the concept of leachate recirculation in the operational requirements of section 360-2.17. More specifically, the current provisions of subdivision 360-2.17(j) state:

(j) Leachate Recirculation. Leachate recirculation is prohibited unless the landfill meets the following requirements:

(1) For existing landfills operating under Part 360 permit and that have received department approval to recirculate leachate, may continue for the duration of the permit or subsequent permit renewals as long as the landfill meets all of the operating requirements of this Part and providing that groundwater monitoring data verifies no landfill induced contamination pursuant to the provisions of Part 703 of this Title.

(2) For all new landfills, or an existing landfill that does not have department approval to recirculate leachate, a double liner system acceptable to the department is required along with demonstration of a minimum of six months of acceptable primary liner performance being submitted for department approval.

(3) In all cases, leachate recirculation is prohibited on areas where any soil cover has been applied unless provisions for runoff collection and containment are provided. In no instance for double lined landfills shall the volume of leachate to be recirculated give cause to increase the primary liner system's leakage beyond the 20 gallons per acre per day operational threshold based on a 30-day average and/or increase the potential for groundwater contamination.

(4) All leachate recirculation proposals must have in support an operations manual prepared in accordance with the provisions of subdivision's 360-2.9(a) and (j) of this Subpart.

The later reference to a landfill's operation and maintenance manual is to ensure that the Division's approval to recirculate leachate is contingent upon assurance that the landfill's primary and secondary leachate collection and removal system (LCRS) is designed with adequate accessibility for routine maintenance, in as much as recirculation of leachate could actively promote concern for increased biological clogging in the LCRS. The other issue at hand from a regulatory perspective is the adherence to the regulatory performance standard for the primary LCRS to allow no more than 1 ft of leachate head on the landfill's liner. It is *not* generally intended that a landfill that will utilize the recirculation practice will be allowed to effectively flood the landfill's waste mass with leachate. To do so would inevitably result in violation of the landfill's primary liner leakage rate threshold and heighten the potential for ground-water impact from the landfill.

Another operational advantage that leachate recirculation provides is the ability to use the retention capacity of the waste mass to buffer peak flows of leachate generated in the landfill, so as to eliminate leachate storage capacity problems at the landfill. Recirculation of leachate should not be perceived to mean that these facilities can no longer deal with leachate

generation and treatment. Ultimately, leachate will need to be treated either on site or off site for discharge.

Another beneficial byproduct of the leachate recirculation concept is enhanced methane gas generation at the landfill and the ability to more easily harness the energy potential of the wastes disposed of in the landfill. Not only will this help to conserve natural energy resources, but it will also have a net environmental benefit of capturing and effectively using landfill-derived methane gas while also controlling the emission of other offensive waste decomposition gases.

As stated above, the regulatory concerns for leachate recirculation revolve around the landfill's operational ability to provide for a high degree of leachate accountability. In pursuing a plan to recirculate leachate, the landfill operator should develop a comprehensive operation plan that effectively describes the leachate recirculation process. Part of this plan should include explicit operational instruction on the leachate recirculation rate. This plan should include a discussion of how continued monitoring of the primary liner's performance will relate to leachate recirculation and the hydraulic loading of the landfill's LCRS. The plan should address the proposed methods of leachate reinduction into the landfill, as well as enhanced landfill gas collection processes for effective odor and emission control. The plan should have a separate contingency plan that addresses, but is not limited to, such items as the potential for leachate surface seeps, odor issues, remedial cleaning/flushing of the LCRS to ensure a free-flowing condition, and increased leachate leakage through the primary liner above the approved leakage rate.

In summary, the concept of leachate recirculation in the spirit of optimized landfill air space and long-term biostabilization of the waste mass has merit. Known secondary derived benefits are associated with landfill leachate recirculation. The regulatory perspective, however, on this modern landfill concept in New York State is one of moderation and caution that hinges on the double-lined landfill's ability to demonstrate acceptable leachate accountability and the related concern for acceptable overall operational performance of the landfill.

#### *Alternative Daily Cover Materials*

It is widely recognized that the 6-in. layer of soil cover material plays a critical role in guarding against adverse operational impacts from the landfill by helping to control vectors, fires, blowing litter, odors, and scavenging. A substantial amount of a landfill's air space (disposal capacity), however, is taken up with the daily application of 6 in. of soil cover material. It has been a standing rule of thumb and standard practice in approximating the capacity of a landfill to estimate air-space ratios for a soil-cover-to-waste-volume ratio of 1:4. The concept of using "soil-like" wastes or synthetic "tarps" in lieu of the conventional 6-in. daily cover soil allows for more cost-effective use of a landfill's disposal capacity from a facility owner perspective. This basically extrapolates down to more disposal capacity for waste and added revenue for the facility owner. In times of a disposal capacity crisis, this is not necessarily a negative attribute. More importantly, natural resources are conserved in these situations. For a hypothetical regional landfill that has a working face of one-quarter acre in size and is operated 6 days a week, the amount of soil daily cover material consumed by this

landfill for the week could be as much as 1,200 yd<sup>3</sup>. If this material has to be delivered to the landfill, the concept of ADCMs could beneficially reduce overall landfill-related truck traffic in the vicinity of the landfill. The monetary gain or the net worth of 1,200 yd<sup>3</sup> of saved disposal capacity is valued at more than \$47,000 of added revenue per week or nearly \$2.5 million per year (based on 1,200 lb/yd<sup>3</sup> in-place density of waste; and a Northeastern tip fee rate of \$66.13/ton, from the Solid Waste Price Index, November 1994 survey).

Under the current Part 360, the daily soil cover requirements, including the operational criteria for daily cover, are specified in the provisions of subdivision 360-2.17(c), which states:

A minimum of six inches of compacted cover material must be applied on all exposed surfaces of solid waste at the close of each operating day to control vectors, fires, odors, blowing litter and scavenging. The department may approve the use of alternative daily cover materials of an alternative thickness, upon a demonstration that the alternative daily cover material will adequately control vectors, fires, odors, blowing litter and scavenging without presenting a threat to human health and the environment. Such demonstrations are not subject to variance procedures of this Part.

As noted above, the state's regulations have incorporated the ability to use ADCMs into the regulations upon demonstration of adequacy, thus incorporating the flexibility imparted under the minimum federal criteria for municipal solid waste landfills (MSWLFs) (40 CFR Subpart 258.21[b]) for landfill operators to seek the state's approval to use an ADCM.

Even beyond this, Part 360's definition of "cover material" generally conveys that materials other than soils may be used for daily cover. Part 360's definition reads:

'Cover material' means soil or other suitable material, or a combination of same, acceptable to the department that is used to cover compacted solid waste in the landfill.

Thereby, the regulations have for some time provided a basis to consider the use of indigenous waste materials for daily cover at a landfill. Use of indigenous material as an ADCM affords optimum cost savings because this material is received at the landfill for disposal anyway, and the landfill operator is typically paid to accept the indigenous material as a waste. This material can be handled by the existing conventional landfill equipment, and thus increased application costs are not realized. This process of using an indigenous waste material as daily cover under the previous version of Part 360 necessitated obtaining a beneficial use determination (BUD) to stipulate that the waste being used as an ADCM would no longer be classified as a waste if used in this manner. The 1993 version of Part 360 now contains a preapproved BUD provision (360-1.15[b][10]) that states that if written approval is obtained from the department to use this waste material as an ADCM, the formal BUD process is waived. The appropriate time for a landfill owner to approach the department with a request to use an indigenous waste material as an ADCM is during the initial application process for the landfill. In so doing, all necessary regulatory approvals can be granted through the application process and any special permit conditions that need to be applied can be issued at that time.

In the case of an existing landfill, the regulatory mechanism to alter a previously approved operation plan for the landfill to address the use of an indigenous material as an ADCM for daily cover is the permit modification process. In this instance, the modification process would need to include the written documentation addressing the modified operations for using the indigenous material as an ADCM. Such permit modification procedures under the provisions of the state's Uniform Procedures Act would almost always be deemed a minor modification and should not be an onerous regulatory undertaking.

Waste materials that would otherwise be disposed of in a landfill may be used as an ADCM providing that the material adequately meets the performance criteria specified in the provisions of subdivision 360-2.17(c), which may include, but not be limited to:

- Foundry sand waste
- Papermill waste
- Processed infrastructure demolition waste
- Select processed building demolition waste
- Select spill debris waste
- Select dredge material waste
- Mixtures/blends of the select waste with soil

Careful assessment of a waste material's physical properties is necessary to ensure that the waste material itself does not have inherent characteristics that could cause operational problems at the landfill. For instance, dredge materials can be malodorous, and processed demolition debris waste can be too dusty and could promote odor or dust control problems themselves. In the selection of wastes as ADCMs, the landfill designer or operator should look for waste materials that themselves do not need to be covered with soil at the end of the day.

Manufactured or processed materials that may be considered as ADCMs and typically take up no volume in the landfill are generally described below:

- Sprayed foams products
- Sprayed recycled paper/plastic slurry products
- Sprayed recycled plastic/woodchip slurry products
- Removable/reusable synthetic membrane or textile products
- Sacrificial synthetic membrane or textile products

Issues that landfill designers and landfill operators should consider when making decisions regarding ADCM selection are as follows:

- Regulatory agency approvals: Modern landfills are authorized to operate in strict adherence to their approved operations plans. Use of ADCMs at a modern landfill must be addressed in the approved operation plan; otherwise, the plan must be modified to reflect this concept. For the modern lined landfill, such administrative permit modifications and related approvals are usually not deemed major actions and are easily and quickly attained.



- **Material permeability:** Will the material impair the ability of leachate to flow through the landfill to the LCRS or likewise interfere with gas collection or cause side-slope leachate seeps at an aboveground surface landfill?
- **Material workability:** Are there factors such as weather conditions (e.g., wind, rain, freezing conditions) that limit when the material can be used? How much time does it take to apply the material at the end of the day? In the case of the removable synthetic tarp as daily cover, what happens if 1 ft of snow falls overnight?
- **Material availability:** Is the material readily available in the necessary quantity that the landfill operation would demand?
- **Storage needs:** Are there special storage needs for the materials? Indigenous waste materials proposed for use as an ADCM need to be stockpiled within the lined area of the landfill, and runoff controls need to be implemented to prevent contamination of surface waters.
- **Specialized equipment:** Does the application of the ADCM require specialized equipment?

The regulatory perspective on the use of ADCMs is favorable. Toward this end, Part 360 now contains reference to the use of ADCMs in subdivision 360-2.17(c). The current Part 360 was revised during the 1992 rule-making effort to in essence streamline the regulatory process for use of ADCMs. Beyond this, the Division also encourages that landfills be operated in an environmentally sound and resource-conscious manner. As referenced earlier, the provisions of subdivision 360-2.9(a) in Part 360 encourage landfill operators to seek out uses of ADCMs in their initial Part 360 applications.

Through these provisions, the current version of Part 360 is consistent with the provisions of 40 CFR Section 258.21(a) and (b) of the federal regulations, which also allow for the use of ADCMs upon demonstration that such materials protect human health and the environment.

#### *Improved Internal Leachate and Gas Removal and Collection System Designs*

A landfill designer's primary goal in developing an environmentally sound disposal facility is to optimize the disposal facility's physical air space or disposal capacity. This design criterion for a landfill's physical capacity usually hinges on the aerial extent and overall depth of the facility. As addressed in the discussions above relative to ADCMs, however, there are further capacity-related gains that can be derived via operational methods that ensure optimum densification of the wastes being landfilled. For instance, landfill operators in certain instances have resorted to baling waste prior to landfilling in an effort to achieve maximum waste density. Even in conventional landfill operations, operators ensure that the maximum in-place densities of waste are obtained through better operational controls such as compaction of waste in thin layers with multiple passes of properly sized and designed compaction equipment.

This essentially means a more dense waste mass within the landfill. This condition tends to be somewhat self-defeating, especially with regard to encouraging effective waste mass biostabilization and leachate recirculation. Not only is the air (oxygen) compressed from the waste, but the waste mass becomes more impervious to internal leachate flow within the landfill's waste mass—two critical aspects essential for optimum waste mass decomposition—which ultimately relates to rejuvenated disposal capacity.

The landfill designer must determine what the optimum waste density for a given landfill will be so that the landfill's environmental containment system can be designed for adequate structural integrity. The landfill operator, in turn, should be made aware of the structural capacity of the landfill so that future changes in waste mass density can be analyzed for adverse effects on the landfill's containment system. In recognizing this current trend of achieving optimum in-place densities of the wastes and its effect of slowing the decomposition process, the landfill designer should consider improved designs for leachate and gas collection systems within the internal waste mass itself to aid in leachate collection or recirculation and to improve methane gas collection. Such concepts could include the use of dual purpose collection pipe networks placed within the horizontal layers of intermediate cover. This network could then be tied to a gas collection manifold or header system at the perimeter of the landfill. This same network could also be used to allow pressurized leachate reinduction into the internal waste mass. The concept of these horizontal gas collection and/or leachate induction networks could prove useful in providing greater waste mass biostabilization on each horizon of waste placed within the landfill.

The modern landfill designer must also take into consideration the selection of intermediate cover material (realizing that this material was traditionally selected to effectively shed precipitation) to preclude this layer from acting as an inhibitor or barrier to internal waste mass hydraulics. In cases where landfills have had gas recovery wells installed through the waste mass, drillers commonly encounter significant areas of perched leachate within the landfill. This condition is worsened when these perched internal hydraulic barriers extend to the sides of the landfill, where they contribute to leachate surface seeps. This problem is easily abated by removing the intermediate cover around the perimeter of the landfill prior to placement of the next lift of waste. The provisions of the current Part 360 in subdivision 360-2.17(d) allow a landfill operator to seek Division approval to remove the intermediate cover layer prior to placement of the next lift of waste, providing that it is demonstrated that odors and blowing litter are effectively controlled.

#### *Improved Surface Water Controls Within the Landfill*

One of the most striking aspects associated with the monitored operation of the double-composite-lined landfill is the amount of leachate that these landfills generate during their early stages of operation (first 1 to 3 yr). Figures 2 through 6 summarize primary liner leakage rates and the total amount of leachate collected at these facilities for the corresponding monthly timeframe. The total leachate generation rate for these sites generally ranged from 500 gpad to just over 3,500 gpad. The higher end values are well above the amount of estimated leachate generation that the design engineer predicted for these facilities based on the empirical derivation of leachate generation via Hydrologic Evaluation of Landfill

Performance (HELP) model analysis. Review of these individual situations does *not* lead to the conclusion that the HELP model analysis is in error, but instead that the amount of runoff from the landfill as predicted in the HELP model analysis could not be separated within the landfill's environmental containment system and thus was collected as leachate.

If runoff control is not considered in the design of the landfill's fill progression plan, the landfill operator in charge of minimizing the amount of leachate generated might find it extremely difficult to divert large volumes of runoff from other portions of the landfill. The problem is that one of the most frequently made changes to approved operational plans is the progression of waste placement in the landfill. A seemingly simple change in a fill progression plan at a landfill can negate the designer's efforts to minimize leachate production. Unfortunately, these subtle changes seem inconsequential until the landfill operator realizes that the landfill's entire annual leachate treatment budget has been prematurely expended. Usually, it is not until this time that proper fill progression and leachate minimization techniques take on an important role for the landfill operator.

In the interest of minimizing leachate production, landfill designers are submitting more complex operational plans that substitute impervious synthetic tarps for daily and intermediate cover materials used to channel uncontaminated surface water runoff collected within the landfill away from the landfill operation to avoid added leachate generation. The use of side-slope gutters on landfill side slopes is another innovative leachate minimization technique. The issue again stresses the fact that even though we have good containment system designs for liners and cover systems, the overall success of a landfill's operational performance still depends heavily on the landfill operator's adherence to approved operational plans.

These leachate reduction concepts at first appear counterproductive to facilitating optimal moisture levels in the waste mass. The concept, however, of improved surface water controls within a landfill to minimize leachate generation can work concurrently with a designed leachate recirculation system to achieve optimal waste mass moisture content and enhanced waste mass decomposition.

By not collecting significant volumes of relatively clean surface water runoff, the landfill's leachate becomes more concentrated in terms of chemical and biological contaminants. This may present complications from a leachate treatment standpoint, but the volume of leachate that ultimately needs to be treated is lower. Commonly, the cost of leachate treatment is based on pollutant loading (generally biochemical oxygen demand [BOD]). Depending on treatment cost arrangements between the landfill owner and the wastewater treatment facility operator, the efforts made to reduce the volume of leachate may not have as much of an economic advantage due to the potential for increased leachate strength.

From a regulatory perspective, the design of a modern landfill operational plan that will greatly reduce leachate generation is an issue that will ultimately have the regulatory agency requiring leachate storage facility capacities based on conventional leachate generation rates. On the other hand, the design engineer's recommended leachate storage capacity will likely be based on the proposed facility's operational plan of reduced leachate production. Based on a review of past landfill operation plans and their empirically derived leachate generation

data for the modern landfill, the Division believes that leachate storage capacity should be conservatively based on the actual "startup" leachate flows that are witnessed at facilities across the state (typical range is 1,200 gpad to 2,400 gpad). In so doing, the design engineer will typically argue that the larger storage volume is unwarranted but that added storage capacity requested by the regulatory agency can often be used by the operator as a safety factor should landfill operations change, not allowing for optimal leachate reduction operation.

### *Deferred Placement of Final Cover at Properly Operating Double-Lined Landfills*

There is a distinct difference between the need for a timely and environmentally sound closure of an existing unlined landfill and the closure of a modern double-lined landfill with acceptable liner system performance being demonstrated. In short, what it settles down to is an assessment of adequate leachate accountability at the landfill. The leachate generation data collected from the double-lined landfills presented earlier stress the fact that all unlined municipal solid waste landfills should be closed in a timely manner with a final cover system that restricts infiltration to the maximum degree. For comparison purposes, the hypothetical 20-acre unlined landfill could account for an annual uncontrolled discharge of more than 12.4 million gal of leachate to the ground-water sources below the landfill (based on an average generation rate of 1,700 gpad) versus the modern double-lined landfill, which has accountability of essentially all leachate generated.

Currently, Part 360 requires that final cover be applied to landfills attaining final elevation within 90 days after final fill elevations have been achieved, unless constrained by documented seasonal conditions. The Division is frequently asked whether this requirement may be temporarily waived or extended to allow the landfill to remain uncovered in order to facilitate enhanced decomposition of the waste mass. The response to these inquiries is that such approval is dependent upon the landfill's liner system performance at that time. If the landfill's liner system is working adequately, the concept of deferred final cover placement in interest of a more stabilized waste mass is sound. The benefit of the deferred placement of final cover is the reduction in cost associated with the long-term maintenance of the final cover system and the possible reduced overall extent of cover that may result from the waste mass volume reduction from enhanced waste decomposition.

### **Conclusion**

In summary, this paper has only begun to address some of the trends associated with operation of the modern double-composite-lined landfill in New York State. It is the intent of this paper to stress to the landfill designer and operator the importance of providing the continued primary liner system performance monitoring as a barometer to measure the overall functional performance of the modern landfill from a containment perspective.

The Northeast continues to experience high disposal fees and periodic shortfalls of available disposal capacity. Realizing this, both landfill designers and operators are advancing optimized landfill operation plans geared to conserve remaining air space. Other concepts

focus on operational plans to minimize leachate generation in an effort to cut costs associated with landfill operation. Many of these concepts have secondary benefits, such as seeking approval to use select waste materials as ADCMs, which may also reduce truck traffic and conserve natural soil resources. With the increased shortfalls of disposal capacity in certain areas, it is important that these requests be heard. In certain instances, these ideas for increasing the landfill's productivity also directly result in a minimized long-term pollution potential from the wastes contained in the landfill.

The topics addressed within this presentation relating to a modern landfill's use of leachate recirculation to actively promote enhanced waste mass decomposition (active landfill management technologies) should be approached with caution. The successful full-scale operation of a modern landfill as a large biodigester has merit. The ultimate goals of such waste management proposals are well founded. We must also be aware, however, that the operational performance of these new landfills is being closely scrutinized. A single failure, even on an isolated account, could further impair the ability to gain public trust and support for these vital disposal facilities. These concerns should not stymie new operational concepts, however, but should reinforce the need for comprehensive and well-thought-out operations and contingency plans associated with the modern landfill's overall performance.

#### References

This paper represents an updated version of the presentation entitled "Operational Concepts of the Modern Double-Lined Landfill," given by the author on January 6, 1992, at the New York State Department of Environmental Conservation (NYSDEC), New York State Association for Solid Waste Management (NYSASWM), and U.S. Environmental Protection Agency sponsored Advanced Landfill Final Cover System Design and Construction Seminar on January 6 through 8, 1992, in Saratoga Springs, New York.

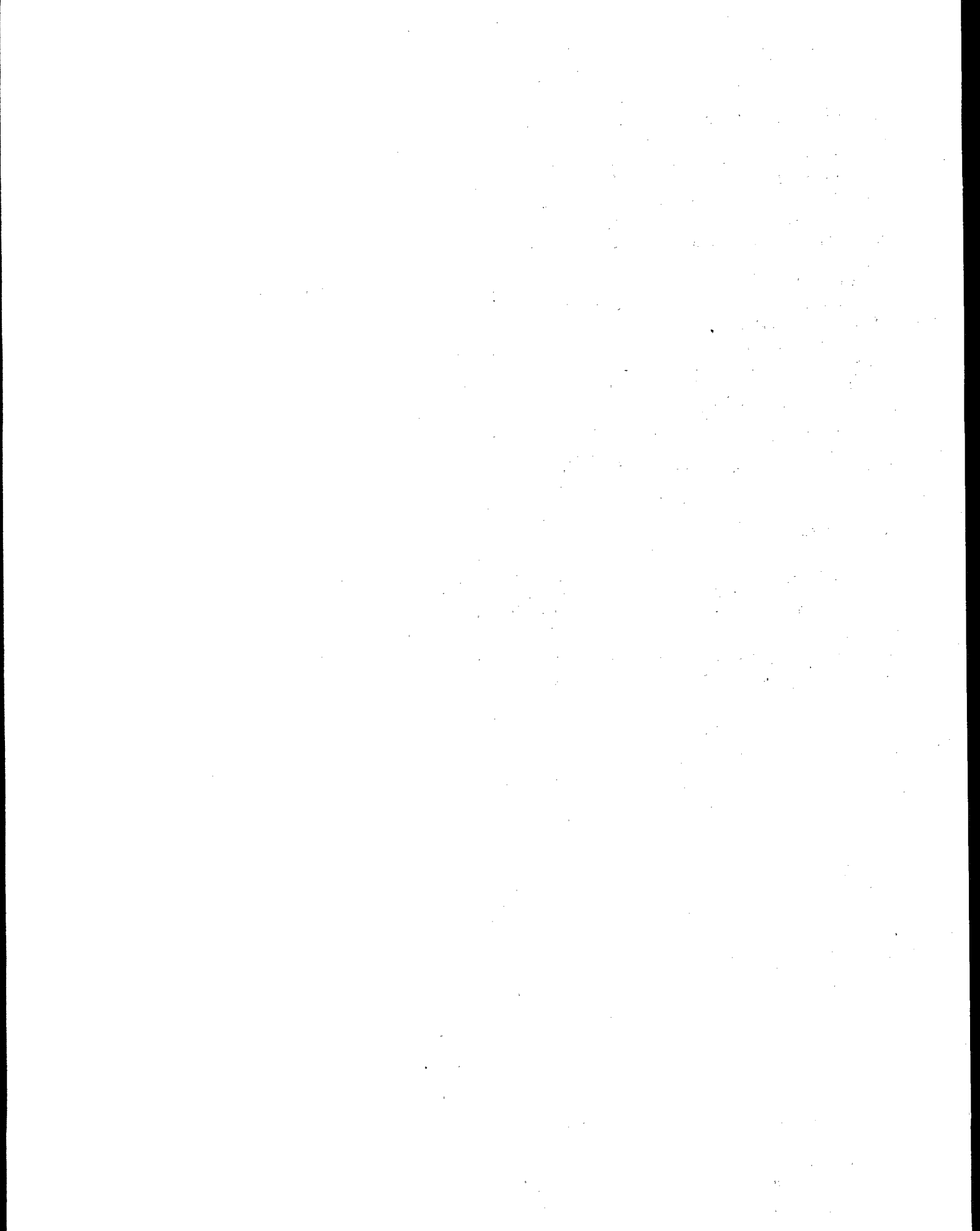

## **Design Elements Associated With Leachate Recirculation at Existing, Unlined Landfills**

---

Stephen R. Harper, Sharon R. Just, and Christopher Donohoe  
Parsons Engineering Science, Inc., Atlanta, Georgia

David A. Carson  
National Risk Management Research Laboratory, U.S. Environmental Protection Agency,  
Cincinnati, Ohio

---

### **Abstract**

Examples of mechanical and civil works needed to implement leachate recirculation at an existing, unlined landfill are presented. The example case represents a remedial action scenario potentially applicable to many closed but problematic landfills across the United States and elsewhere. The subject landfill does not have a bottom liner, and ground water flows through the bottom of the fill, requiring external measures for leachate containment, capture, and control. Described in this paper are design elements associated with leachate containment, collection, storage, pumping, and leachate reinjection, as well as with gas collection and final capping.

### **Introduction**

#### *Purpose*

The purpose of this paper is to provide descriptions of design elements associated with implementing leachate recirculation at older landfills that do not have bottom liners. The objective of implementing recirculation is to operate the landfill as a bioreactor and thereby stimulate waste conversion and gas production to effect a reduction in toxicity, mobility, and volume of toxic organics and heavy metals.

At existing landfills, leachate recirculation is the only technology that offers potential reductions in the mass of hazardous as well as nonhazardous materials at the source. As such, recirculation represents a potentially viable remedial technology, applicable where hydrogeologic conditions allow for the retroactive installation of effective leachate containment and collection devices. Because the invasive techniques required for recharge well installation must be applied with due safety protection, the costs of these systems are higher than would be required for newer modern landfills. A higher degree of regulatory interaction prior to and during recirculation for remedial purposes is to be expected, resulting in a higher degree of monitoring and data interpretation than would be required for normal landfill operations.

---

### *Scope and Organization*

Details of civil and mechanical works required for implementation of leachate recirculation systems are illustrated with examples from the preliminary design report for the Center Hill Landfill (CHL) in Cincinnati, Ohio (1). The CHL requires mitigative action due to risks posed by potential ingestion of soil and surface water, based on contamination of these media with organic and inorganic contaminants described in the next section.

The report contains details of a preliminary design developed under sponsorship of the U.S. Environmental Protection Agency's (EPA's) Risk Reduction Engineering Laboratory to evaluate the feasibility of using recirculation for remediation of problematic landfills that do not have bottom liners. The CHL was selected as the study site for this project and is described briefly here and in more detail in Westinghouse, 1992 (2). Details of the landfill are summarized in Table 1 and discussed further in the next section of this paper.

**Table 1. General Characteristics of the CHL Landfill Site**

| Characteristic            |  |
|---------------------------|--|
| Location                  | Cincinnati, Ohio   |
| Operating history         | Open from 1946 to 1972   |
| Area (ac)                 | 61 (city-owned fill area)  |
| Depth (ft)                | 20 to 35 (maximum)   |
| Waste mass (tons)         | Unknown, possibly 1.5 million                                      |
| Liner/leachate collection | One leachate collection trench exists; others proposed             |
| Final cap                 | Soil cap exists; improved soil cap proposed                        |
| Wastes types              | Municipal waste, industrial waste, incinerator ash                 |
| Number of recharge wells  | 400 linear ft of horizontal wells and 0.75 vertical wells per acre |

### **Description of Center Hill Landfill Site**

The CHL occupies approximately 55 acres and is located in the west-central region of the greater Cincinnati area, approximately 15 miles from downtown, as shown in Figure 1. The site is bounded by Mill Creek on the east and south, by the former Ridgewood Arsenal site to the northeast, and by a construction company to the northwest. The former Ridgewood Arsenal site to the northeast is being developed as a commercial and light industrial park.

The CHL received residential, municipal, solid, and industrial waste from around 1946 until its closure in 1977. Random open dumping and disposal of wastewater grit continued at the



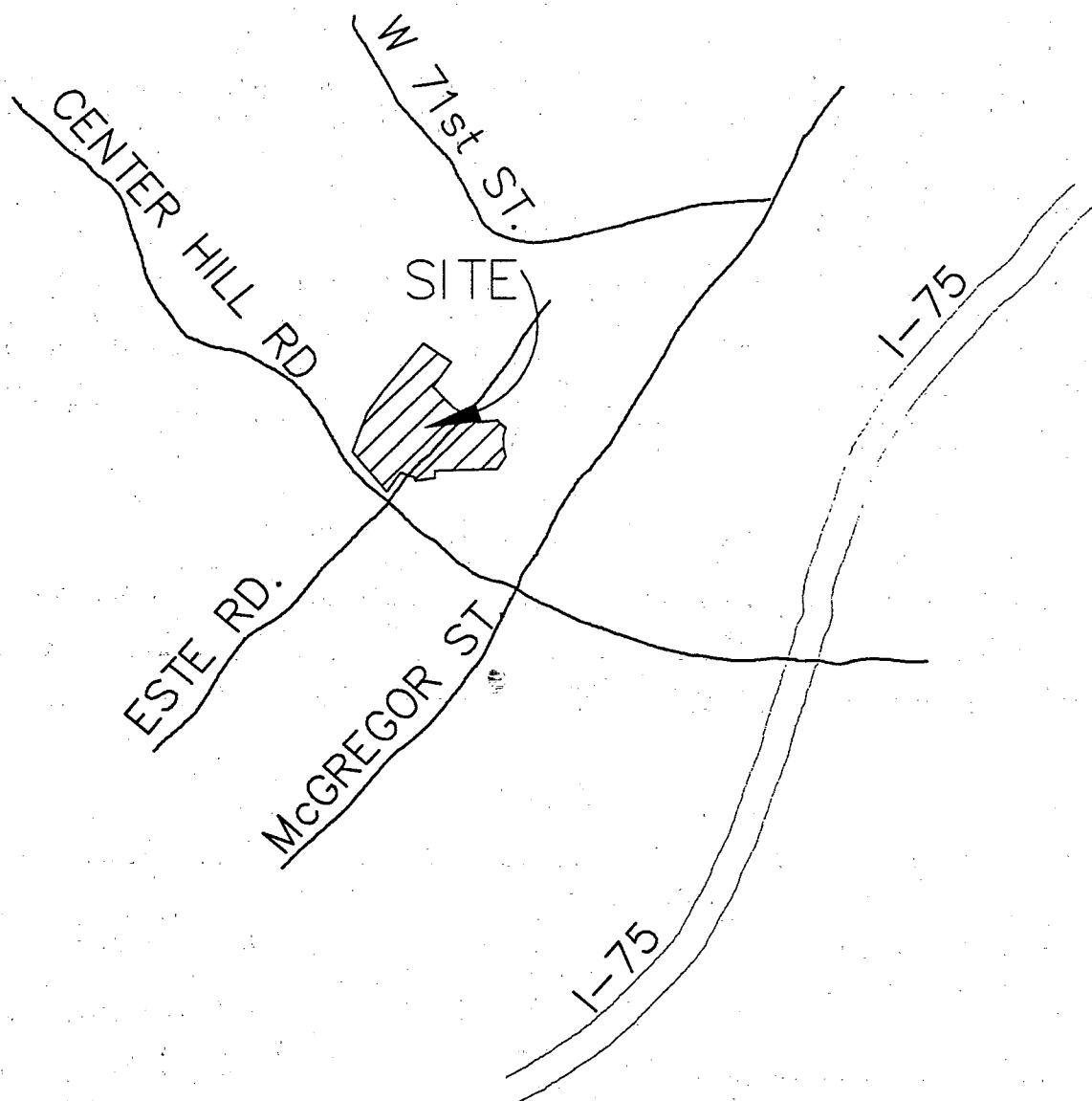

**Figure 1. Center Hill location map.**

site through 1983. The landfill is adjacent to an abandoned solid waste incinerator, and historically received ash from the incinerator. Known industrial wastes placed in the landfill included fly and coal ash, paint solids, chemical coatings, oils, solvents, and various metals.

#### *Landfill Description and Hydrogeology*

The history of the site prior to 1955 is not well documented. Based on historical topographic maps, the area appeared to have been surface mined for sand and gravel and the resultant pits subsequently filled with surface and ground water. When filling operations began around 1946, it is probable that no liner was constructed, and natural in-place soil essentially served as the base.

Landfill materials underlie most of the site, up to a maximum thickness of approximately 40 ft. Beneath the landfill waste mass is a 1- to 10-ft-thick layer of sand and gravel that appears, for the most part, to be continuous. A 40- to 50-ft-thick layer of lakebed clay underlies the layer of sand and gravel.

A surficial aquifer is present in the sand and fill overlying the lakebed clays. The surficial aquifer is approximately 5 ft thick and is approximately 30 ft below land surface (bls). Hydrogeological data indicate that a portion of the refuse is in constant contact with the surficial aquifer. Ground-water flow is presently drained by a leachate collection trench to the east and by Mill Creek to the south.

In addition to the surficial aquifer, a deeper aquifer exists approximately 80 ft bls and extends to an unknown depth beneath the site. A hydrogeological connection may be present between the two aquifers, but the extent and impacts of these potential connections have not yet been conclusively determined.

A cap integrity study indicated that the thickness of cover soils generally ranges from 2 to 4.5 ft, although fill materials are exposed in a few areas. A significant quantity of water infiltrates the surface. Surface drainage is generally to the east (toward a drainage swale), south (toward Mill Creek), and southwest (toward the old incinerator). Pondered surface water observed at the site indicates areas of poor drainage and impacts from settling.

#### *Nature of Contaminants*

Samples have been collected to assess contaminants in surface soils, ground water, surface water, and ambient air (due to gaseous emissions from the landfill).

A preliminary risk assessment was conducted to evaluate exposure routes to children from incidental ingestion of soil and surface water, based on samples collected in 1989. The results indicated that soil ingestion presented a chronic exposure risk from lead and chlordane as well as a  $10^{-3}$  risk level due to exposure to arsenic, chlordane, polychlorinated biphenyls (PCBs), and naphthalene. For surface water ingestion, detections of vinyl chloride resulted in a  $10^{-5}$  risk level, based on leachate samples collected from a drainage ditch.

Gas samples that were collected in 1991 from five methane probes and analyzed for volatile organic compounds (VOCs) contained detectable levels of acetone, benzene, 2-butanone, carbon disulfide, chlorobenzene, 1,1-dichloroethane, 1,2-dichloroethene, ethylbenzene, tetrachloroethene, toluene, 1,1,1-trichloroethane, trichloroethene, and xylenes. The VOC concentrations in the gas samples, however, were all below Occupational Safety and Health Administration (OSHA) permissible exposure limits (PELs).

Ground-water samples from the surficial aquifer reveal elevated levels of VOCs, semivolatile organic compounds (SVOCs), and priority pollutant metals. The most prevalent metals were arsenic, copper, lead, and zinc. VOCs that exceeded maximum contaminant levels (MCLs) included benzene, vinyl chloride, and trichloroethane. Elevated SVOCs included naphthalene, benzoic acid, 4-methylphenol, phenol, and bis(2-ethylhexyl)phthalate. Free product consisting of a black, viscous liquid of "gasoline-type" compounds was also found in one well.

The ground-water data indicate that the surficial ground-water system appears to have been contaminated by leaching of constituents from landfill materials.

### *Relevance of Leachate Recirculation to the Center Hill Landfill*

As summarized above, the concentrations of chemical compounds present in the ground water and soil pose a potential risk to human health and safety and to the environment. Despite attempts to collect and contain the landfill leachate, periodic breakouts (through the side of the fill) have occurred. In addition, VOCs generated by the landfill may migrate and cause a hazardous condition. Leachate recirculation, a remedial technique in which leachate is collected and recirculated through the landfill to promote the breakdown of organics, decrease the concentrations of heavy metals, and contain gasborne contaminants, is a promising method that can help to alleviate contamination and reduce risk at the CHL by in-situ source reduction (3).

### **Description of Leachate Recirculation Design Components**

Preliminary design accommodates leachate collection, storage, pumping, horizontal and vertical injection wells, gas collection and disposal/recovery systems, and a final cap. Beginning at the bottom of the landfill and proceeding upward, details of key design components are described briefly here, in the following order:

- Leachate containment and collection
- Leachate storage and pumping
- Leachate reinjection wells
- Gas collection system
- Final cap system

### *Leachate Containment and Collection*

Whereas leachate containment and collection are accomplished with liner materials in the case of new construction, ground-water diversion and collection systems (trenches and/or networks of vertical and horizontal wells) are required for existing, unlined landfills. These must be designed in recognition of prevailing subsurface hydrogeological conditions as well as site-specific climatic variables.

At the CHL, surficial ground water intermittently comes in contact with the bottom layers of refuse and a sand/gravel layer underlying the site (see Figure 2). Beneath the sand/gravel layer is a clay layer, which confines flow primarily to the sand/gravel layer. A soil/bentonite (slurry) wall was developed for ground-water flow diversion at the upgradient boundary of the site, and a gravel backfilled collection trench was developed for the downgradient boundary (see Figure 3).

Under prevailing conditions, the slurry wall (see Figure 4) would provide only a small reduction in total leachate flow and was not considered cost-effective. It is shown here to illustrate details associated with its potential application here or at other landfills. Details of the ground-water and leachate collection trench developed for the downgradient boundary of the CHL are shown in Figure 5. The trench extends into the clay layer underlying the sand and gravel layer that supports the refuse.

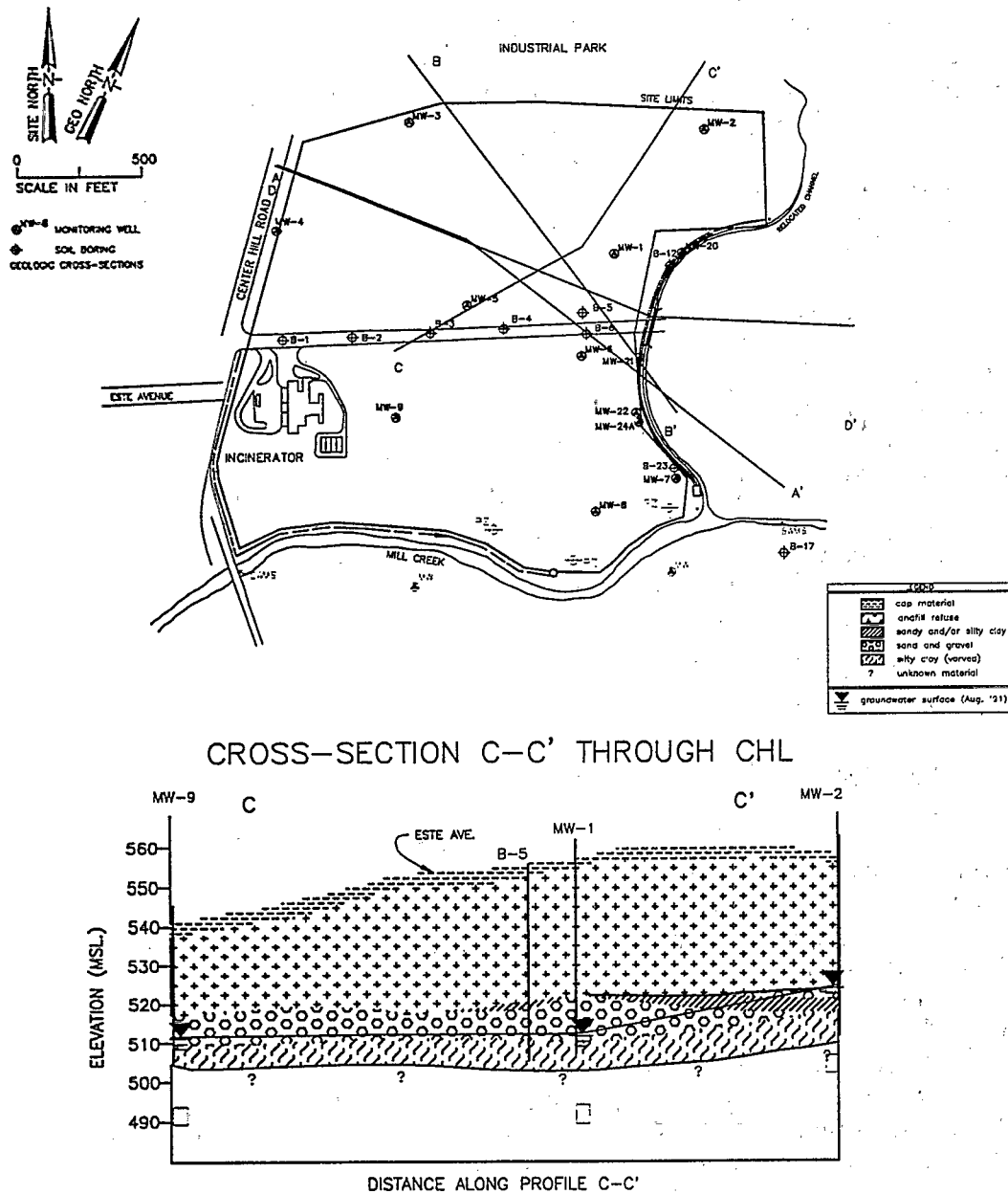

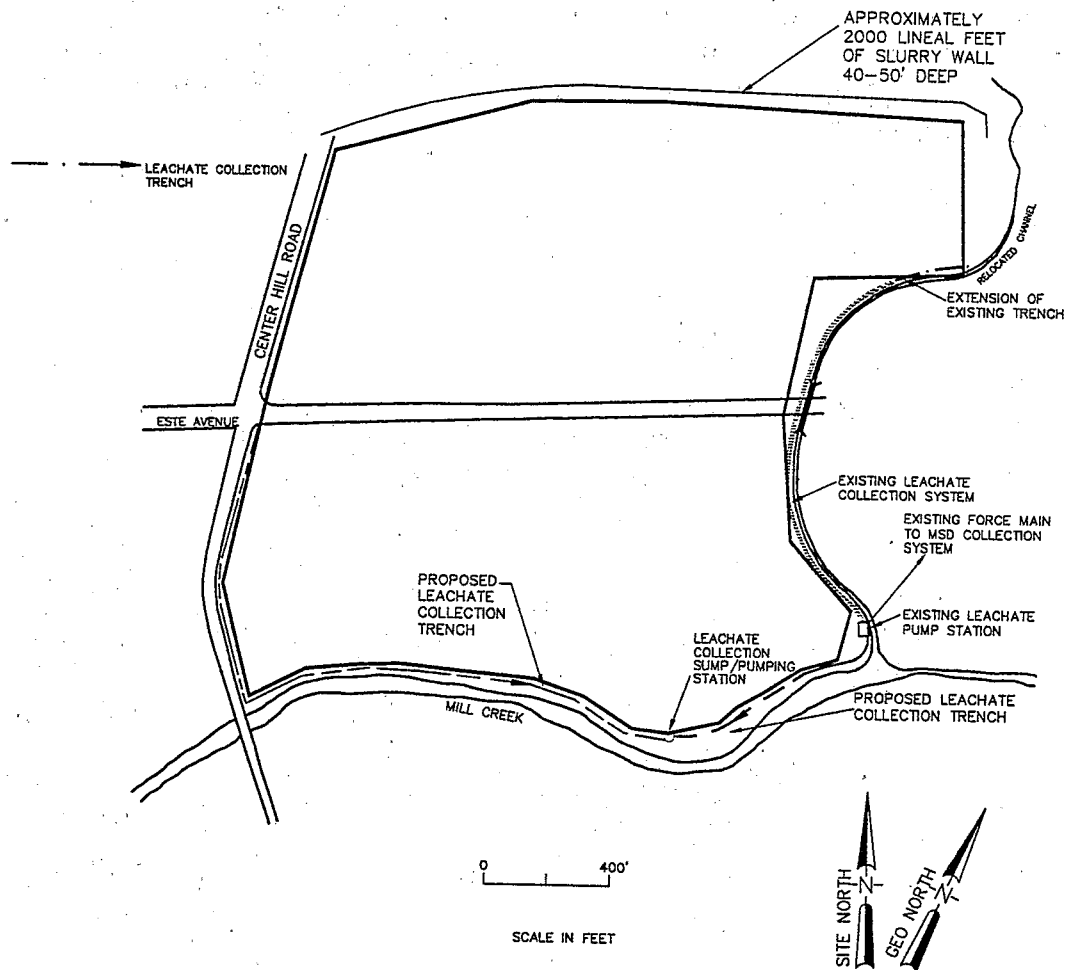

**Figure 3. Site layout.**

### *Leachate Storage and Pumping*

Leachate is collected by gravity in primary manholes located within the collection trench system. The sumps within the manholes feed externally located storage tanks via pumping stations (see Figure 6). Pump and pipe sizes are dictated by leachate flows, which depend on climatic and hydrogeologic factors, choices of technologies applied for containment and capping, and the nature of the refuse in terms of its ability to absorb moisture.

To maximize leachate treatment benefits and contaminant degradation rates, it is most often preferable to keep as much leachate as possible on site. This approach causes leachate to

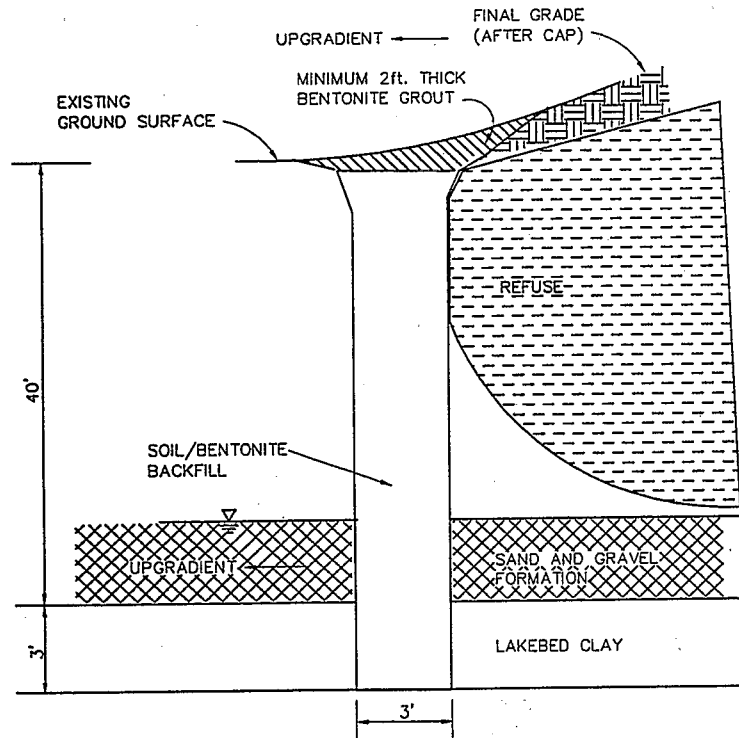

Figure 4. Slurry wall detail.

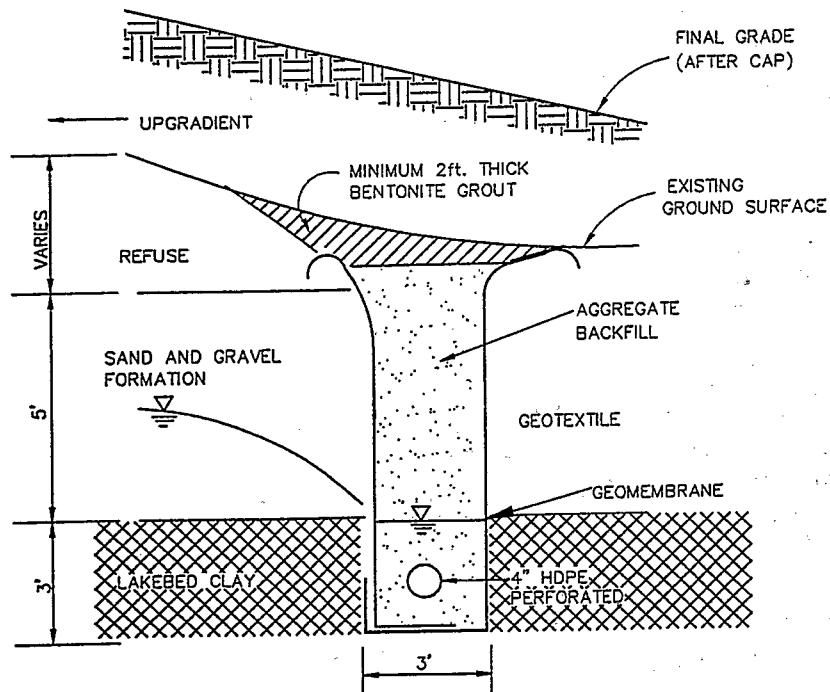
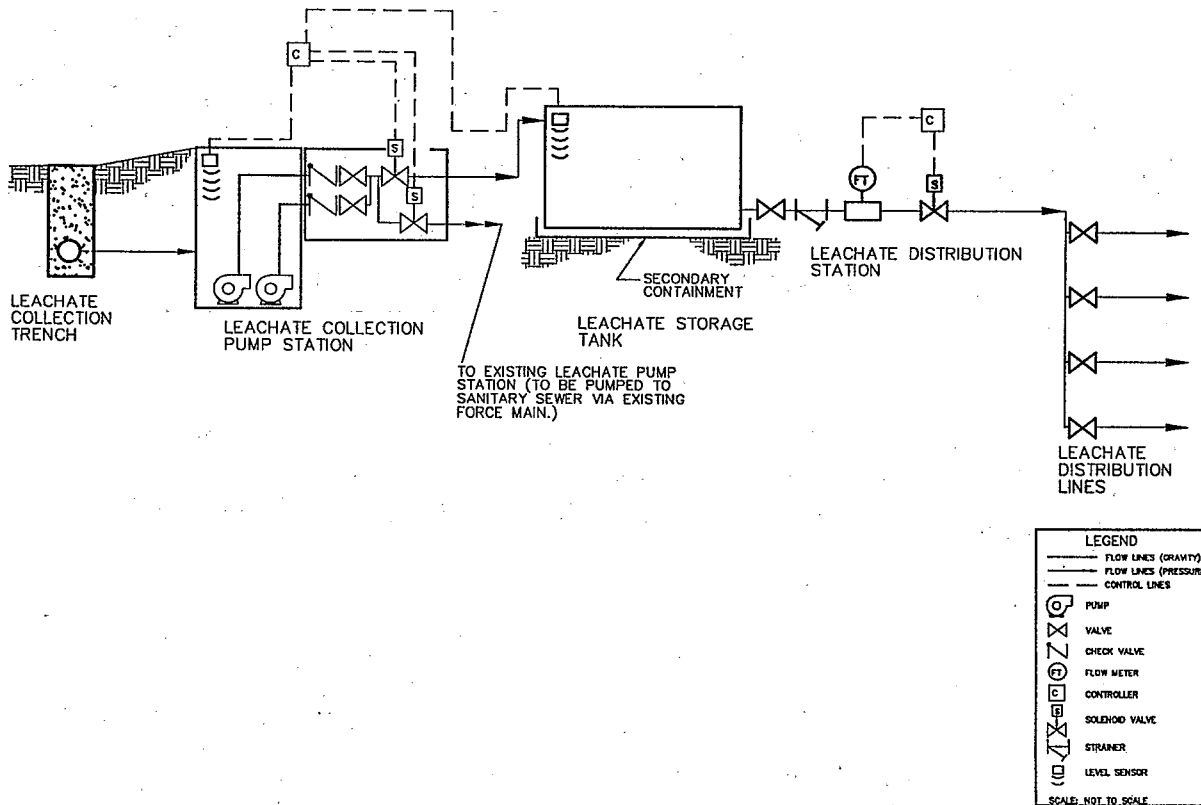

Figure 5. Leachate collection trench detail.



**Figure 6. Leachate pumping system.**

accumulate over time, however, not only in the refuse itself but also in the storage system. To prevent overloading the storage system, it is necessary to increase leachate reapplication pumping rates over time.

Predictions of leachate accumulations in the landfill and/or storage system can be generated using assumptions or measurements of moisture contents, and hydraulic conductivities of refuse and soil layers together with data on their potential absorption capacities and rates of absorption. As leachate production is variable by nature of the storm events from which it originates, a reasonable peaking factor in pump sizing should be considered together with specification of multiple parallel pumps to allow maximum operational flexibility. Alternatively, arrangements to dispose of leachate periodically can be made, such as via transport to an offsite treatment facility or by onsite treatment and discharge via National Pollutant Discharge Elimination System (NPDES) permit (4).

### *Leachate Reinjection Wells*

The CHL has been designed with vertical and horizontal leachate recharge wells. Horizontal wells provide for wide area distribution, while vertical wells help leachate infiltrate through daily cover and other layers of low-permeability material. In placing these wells, it was assumed that horizontal dispersion would be 1 ft laterally per 4 ft of vertical percolation (5).

The layout and a vertical profile of recharge wells for the CHL are shown in Figures 7 and 8. Both types of wells are intended to be operated by filling them completely in selected sections, then allowing a sufficient drainage period. For example, the wells shown in Figure 7 are labeled with M through F, for Monday through Friday, and reflect a 5-day operational week. Storage tanks are provided to store at least 2 days of leachate generation under the worst conditions. During the operating week, the wells themselves provide significant storage volume and the flexibility needed to ensure complete emptying of the storage tank at the end of each week.

### Horizontal Wells

The horizontal wells designed for the landfill consist of gravel backfilled trenches. At the CHL, these wells are designed to be trenched in 2-ft by 2-ft dimensions, equipped with 4-in. perforated drain pipe, and filled with gravel. The wells will be constructed immediately beneath the final cover as shown in Figure 8.

### Vertical Wells

The vertical wells for the CHL are also shown in Figure 8. These consist of perforated pipe sections backfilled with gravel, scrap tires, or other materials of suitable porosity and permeability, and will be fed through laterals of perforated and nonperforated pipe. Wells may be "single-stage," or separated into multiple stages (or sections) by placing impermeable layers and providing additional piping.

Multiple staging is important because better control over injection depths can be achieved by providing multiple injection points. While vertical wells withstand the destructive forces imposed by settlement better than horizontal wells, they are more prone to biological plugging. Corrective maintenance options for these wells are limited to flushing techniques, and these wells are usually simply abandoned after plugging. Redundancy of both wells and injection points within wells is therefore recommended.

### *Gas Collection and Disposal Systems*

The gas collection system consists of interconnected vertical wells similar in construction to vertical leachate recharge wells. A preliminary collection well layout for the CHL is shown in Figure 9 and the details of a typical gas recovery well in Figure 10. A gas collection system process and instrumentation diagram for the CHL is shown in Figure 11. Although it is feasible with proper scheduling of leachate dosing activities to utilize gas wells as recharge wells, this system was not designed as such to avoid potential plugging problems that might incapacitate the gas wells and require future intrusion into the landfill for maintenance of well replacement.



# HORIZONTAL RECHARGE TRENCH LAYOUT - CHL

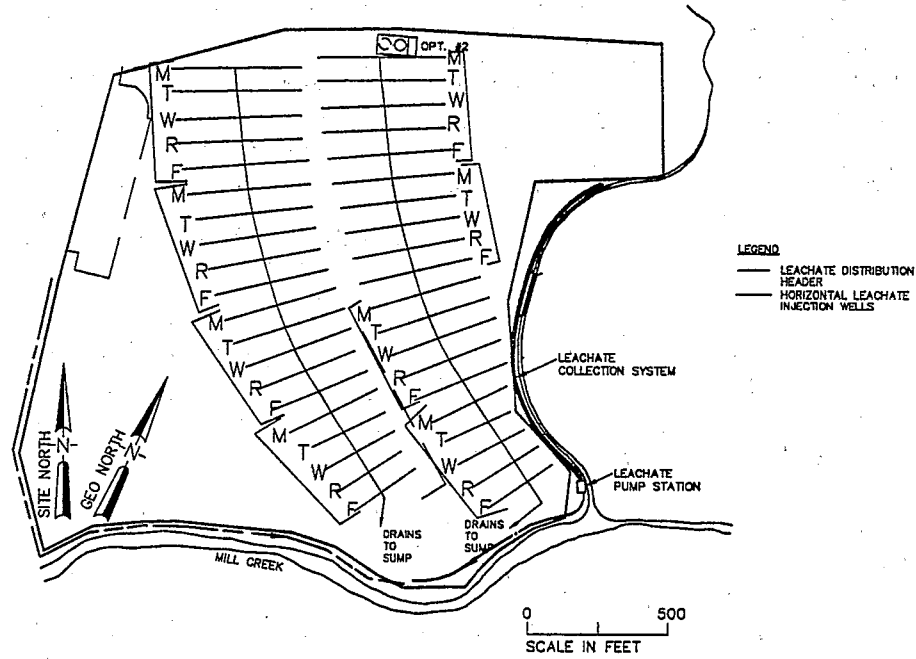

# VERTICAL RECHARGE WELL LAYOUT - CHL

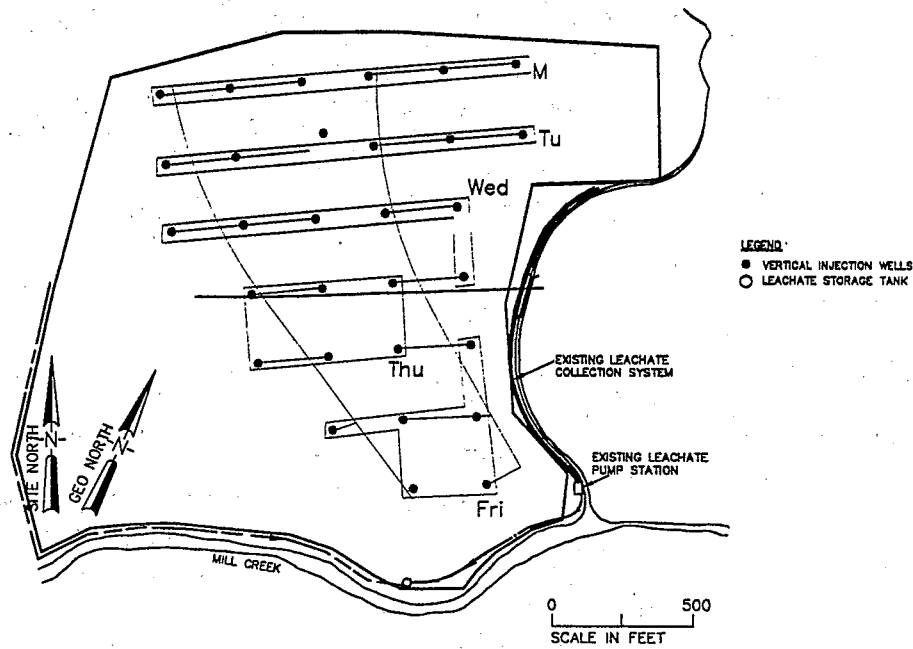

Figure 7. Horizontal recharge trench layouts and vertical recharge well layout.

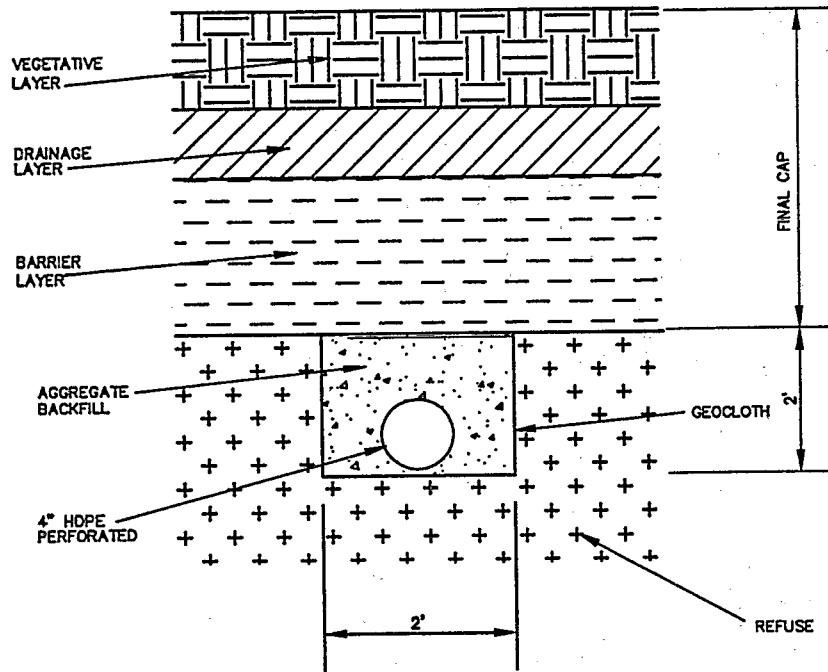

Figure 8A. Horizontal leachate distribution trench.

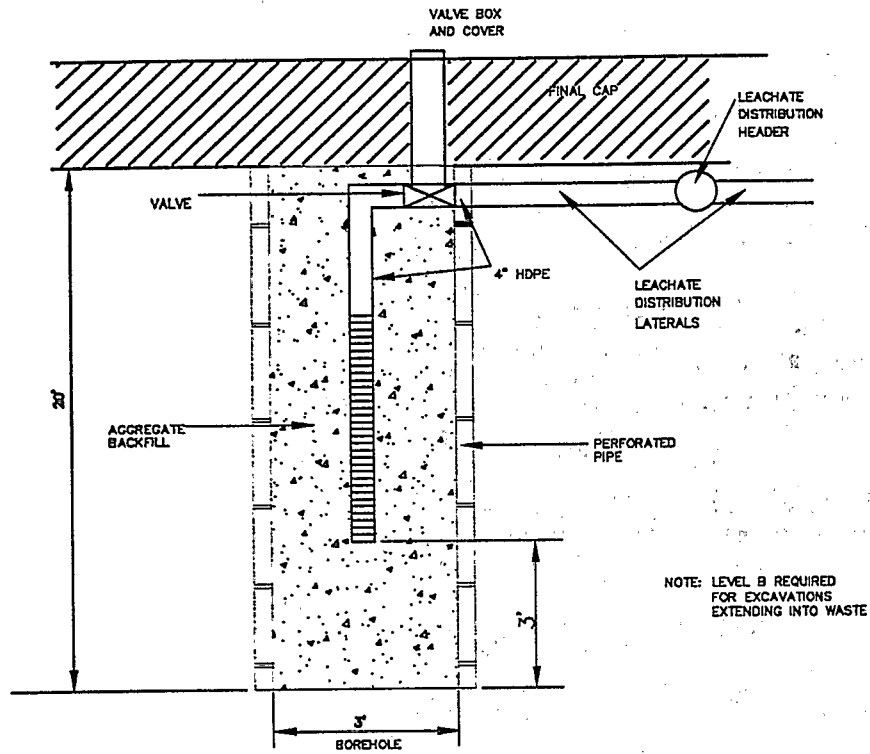

Figure 8B. Vertical leachate distribution well detail.

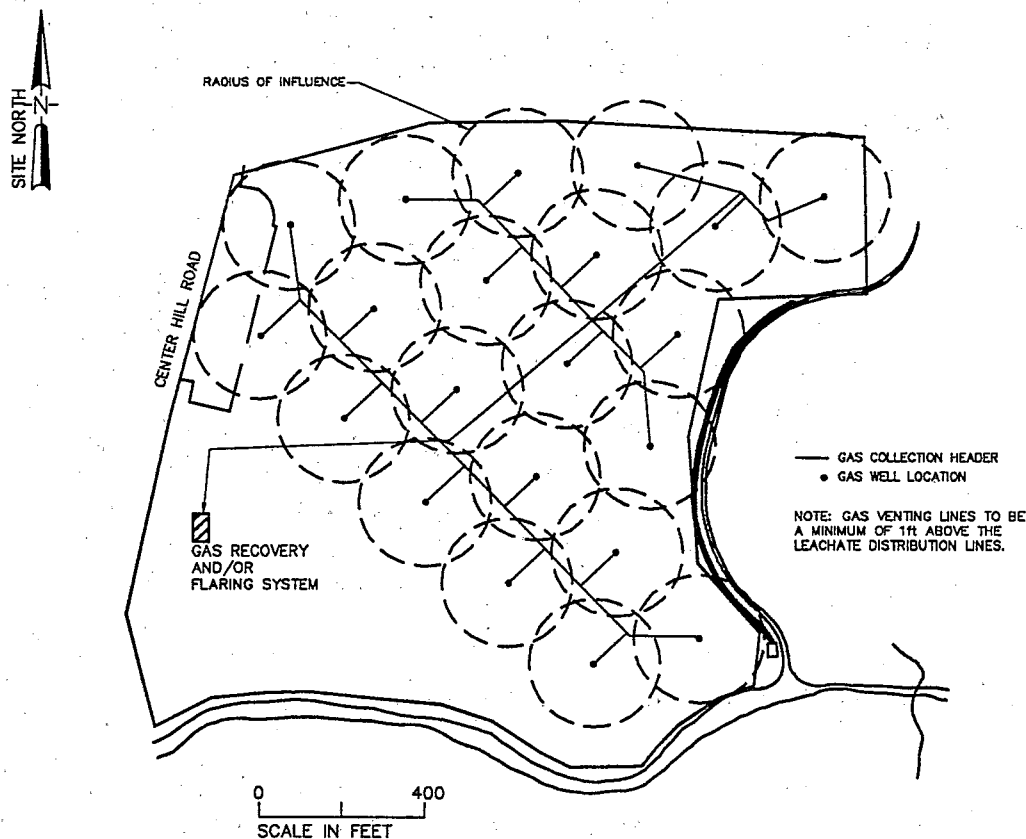

Figure 9. Gas collection well layout.

### *Final Cap*

The final cap involves several layers, as shown in Figure 12. The uppermost layer is the vegetative layer intended to prevent erosion and maximize evapotranspiration. The vegetative layer is underlain by a drainage layer of gravel and stone. Beneath this is an impermeable clay layer. Alternatively, a geomembrane can be used in place of the clay barrier layer.

The final cap is the most important element with respect to influencing leachate production rates and, therefore, leachate recirculation rates. Soil caps made of clay reduce leachate production by 70 to 90 percent, whereas synthetic liners can reduce leachate by 95 percent or more. It must be recognized that leachate production, while viewed as a liability with traditional landfilling methods, is a necessary and beneficial element of recirculation approaches, where enhanced waste degradation and gas production are the objectives.

It should also be noted that landfill waste materials have a tremendous amount of absorption capacity. It is possible, particularly with a geomembrane cap, to be faced with insufficient water to achieve desired moisture contents over sufficiently broad areas.

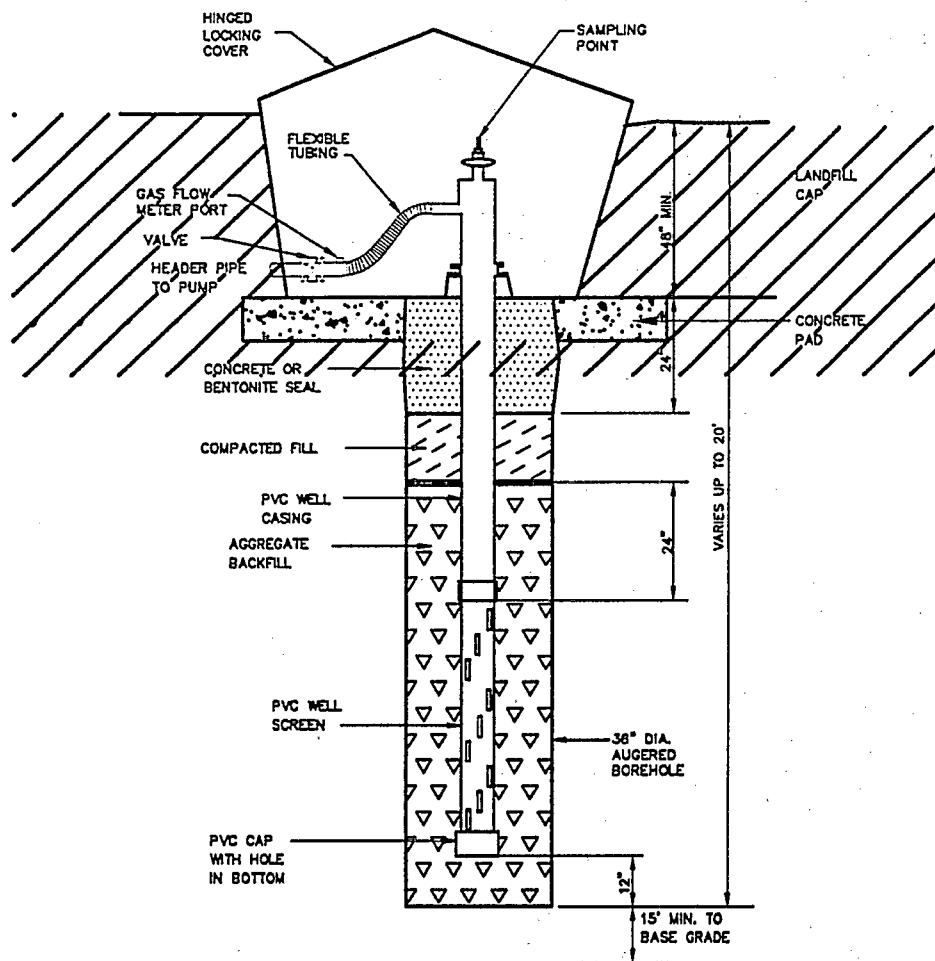
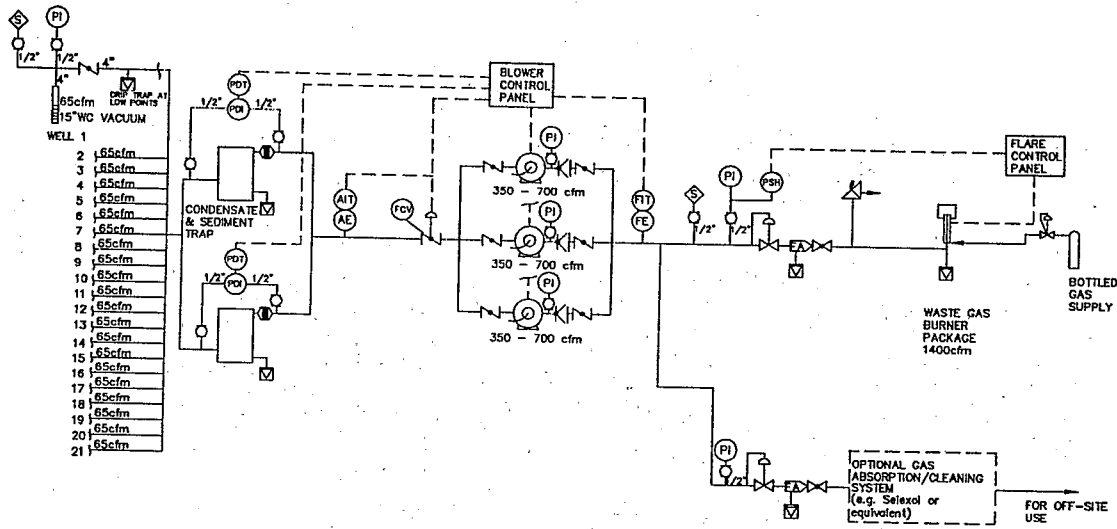

Figure 10. Gas collection well detail.

### Summary

Leachate recirculation can be used to meet several objectives at solid waste landfills: leachate treatment; waste stabilization, including reduction of hazardous wastes at the source; and controlled gas production and recovery. Design elements associated with accomplishing these objectives include leachate containment and collection systems, leachate storage and pumping, leachate recharge systems (horizontal and vertical wells), gas collection equipment, and a final cap system. Examples of these elements illustrated in this paper represent state-of-the-art concepts applied as a remedial measure for problematic, unlined landfills.



**LEGEND:**

|                        |                                   |
|------------------------|-----------------------------------|
| CENTRIFUGAL BLOWER     | FLOW CONTROL VALVE                |
| BUTTERFLY VALVE        | OXYGEN INDICATING TRANSMITTER     |
| DRP TRAP               | OXYGEN ELEMENT                    |
| RELIEF VALVE           | DIFFERENTIAL PRESSURE TRANSMITTER |
| PRESSURE CONTROL VALVE | FLOW INDICATING TRANSMITTER       |
| FLAME TRAP             | FLOW ELEMENT                      |
| WATER TYPE CHECK VALVE | PRESSURE SWITCH (HIGH)            |
| SAMPLING PORT          | PRESSURE INDICATING TRANSMITTER   |
| DEMISTER               | DIFFERENTIAL PRESSURE INDICATOR   |
|                        | PRESSURE INDICATOR                |

**Figure 11. Gas collection/processing system.**

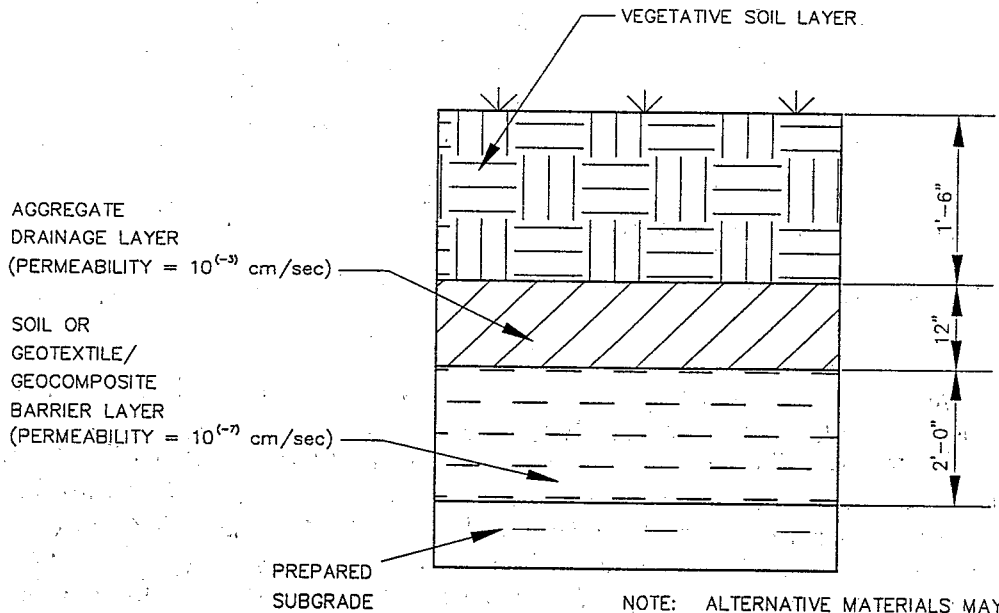

**Figure 12. Final cap detail.**

## References

1. Harper, S.R., and D.A. Carson. 1993. Leachate recirculation for remedial action at MSW landfills: Technical analysis. U.S. EPA Risk Reduction Engineering Laboratory, Contract 68CO0047.
2. Westinghouse Environmental and Geotechnical Services. 1992. Center Hill landfill site investigation report.
3. Harper, S.R., and F.G. Pohland. 1988. Design and management strategies for minimizing environmental impacts at municipal solid waste landfill sites. Presented at the Joint ASCE-CSCE Environmental Engineering Conference, Vancouver, BC (July).
4. Harper, S.R., F.G. Pohland, and G.C. Patrick. 1993. Leachate treatment using recirculation and physical-chemical polishing. Presented at the Georgia Water Pollution Control Association Industrial Conference, Atlanta, GA (March).
5. Al-Yousfi, B., and F. Pohland. 1993. In: Proceedings from 31st Annual SWANA International Solid Waste Exposition, San Jose, CA (August).

## **Landfill Bioreactor Instrumentation and Monitoring**

---

Don Augenstein  
IEM Inc., Palo Alto, California

Ramin Yazdani  
Yolo County Department of Public Works, Davis, California

---

### **Abstract**

A number of landfill bioreactor measurements can be helpful in monitoring, controlling, and assessing progress of stabilization. Useful measurements include moisture content, moisture movement and temperature within waste, leachate flow and composition, and leachate pH. The anaerobic transformation of the organic fraction can be measured through gas flow rate, gas composition, and volume reduction.

Bioreactor landfill measurements may be demanding compared with measurements for "conventional" landfills. For example, gas generation is a good index of decomposition. Bioreactor gas recovery rates can vary over time scales from hours to years, however, and are often difficult to predict. Wide instrument range, and cumulative measurement, are necessary. In situ monitoring in the landfill environment requires robust instruments and careful installation techniques. In-waste sensors require leads, which can be subject to breakage; lead and sensor protection can be accomplished by various means including enclosure in rugged pipe. This document provides a general overview of reasons for various measurements, instrumentation types, and approaches for addressing some common problems.

### **Introduction**

With "conventional" landfilling—defined here as the practice at most U.S. landfills—waste is placed in conformance to existing regulations. There is no particular attempt to manage conditions within the waste to facilitate biological reactions. Waste does decompose after landfilling (albeit slowly), however, and gas recovery may be practiced. Conventional landfilling usually has rather limited measurement needs associated with it. These may include monitoring of a recovered gas stream whose flow and composition remain relatively constant. Sometimes there is monitoring of ground water and soil methane to determine if there is undesirable migration of dissolved or gaseous species from waste to surroundings.

An alternative to "conventional" practice is to manage the landfill as a bioreactor in order to facilitate and speed biological reactions, methane generation, and waste stabilization. (This has been termed "controlled landfilling," with the landfill referred to as a "bioreactor landfill." Both terms are used below.) Controlled landfilling advantages can include waste volume reduction, increased energy recovery, and reduction of long-term landfill care costs, as

---

addressed in other presentations of this symposium. Operation of the landfill as a bioreactor will benefit from monitoring and control of a variety of parameters, including (but not limited to) moisture, pH, temperature, nutrients, and other factors discussed below. In addition, landfill bioreactors must be shown to operate within the constraints of all of the various regulations that affect landfills. Thus, numerous measurements can be quite useful in optimizing conditions and following performance. Some of the more important measurements are listed in Table 1.

The purpose here is to give readers, many of whom may be relatively unfamiliar with bioreactor landfills, a sense of why and how some measurements are made. The purpose of this paper is not to provide extensive detail on specific measurements or equipment (which in any case would be voluminous). Rather, the paper overviews measurements of Table 1 in general terms: importance of the measured parameter, instrument principles, issues and problems experienced in past test situations, and possible approaches that may be taken to overcome past difficulties.

**Table 1. Important Landfill Bioreactor Measurements (Partial List)**  
(See text for discussion)

|  |
|--|
| <b>1. Moisture content/activity/matric potential in waste mass</b> |
| <b>2. Total gas generation (normalized to waste)</b>               |
| Rate of generation   |
| Cumulative generation  |
| <b>3. Gas stream composition (methane content)</b>                 |
| <b>4. Internal temperature in waste mass</b>                       |
| Temperature by location  |
| <b>5. Leachate flow rate</b>                                       |
| <b>6. Leachate composition/characteristics</b>                     |
| pH   |
| Nutrient content ( $\text{NH}_4^+$ , $\text{PO}_4^{=}$ ,)          |
| Alkalinity   |
| <b>7. Waste characterization</b>                                   |
| Cellulose content  |
| Ash, lignin content  |
| Nutrient content   |
| <b>8. Hydrostatic head, key locations (base)</b>                   |



## Measurements

### Moisture

Biological reactions leading to waste decomposition and methanogenesis can be promoted by numerous factors. While other factors can be important, moisture is paramount—essential for biological activities of methane generation. It is quite effective by itself (without other measures) in enhancing biological activity and methane generation with typical municipal wastes. Importance of moisture is illustrated by results of one survey showing effects of moisture on gas generation from solid waste as shown in Figure 1.

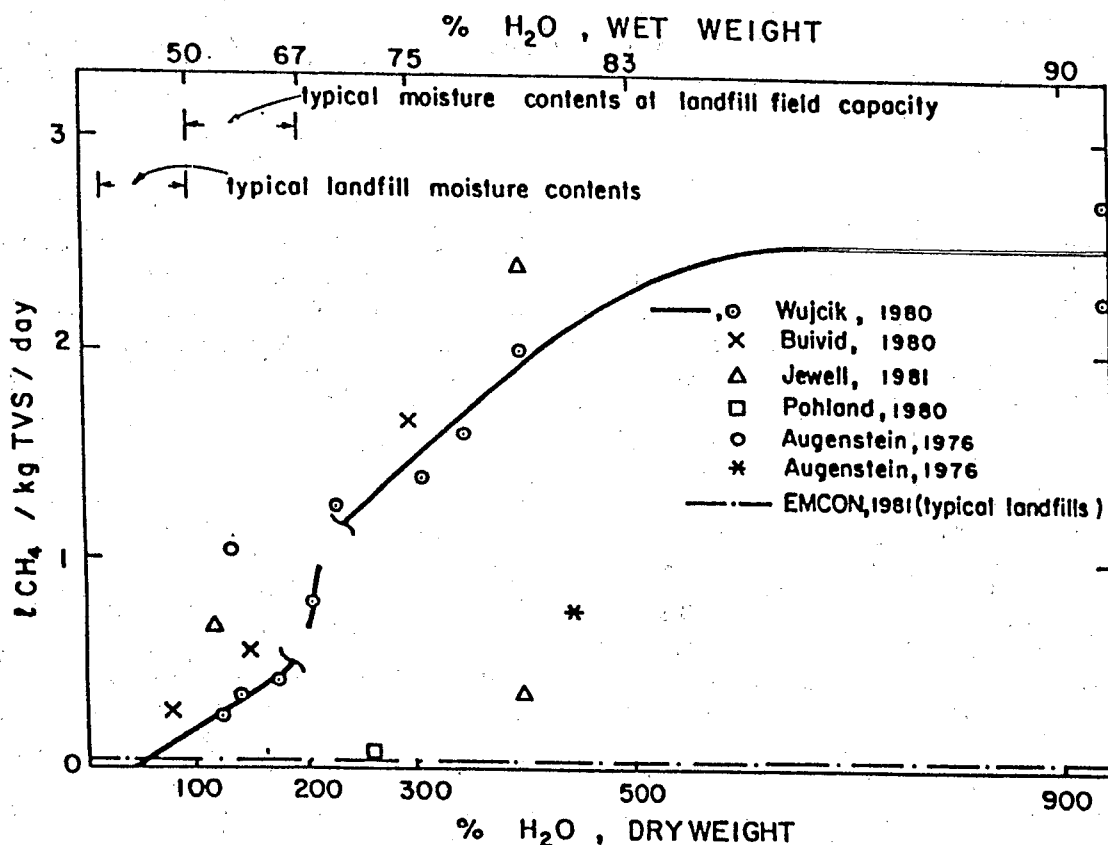

Figure 1. Methane production rate versus moisture content (1).

Moisture content at locations throughout the waste mass can be measured in situ by types of sensors (gypsum or other porous blocks) used in soil moisture determinations. Such sensors rely on electrical capacitance of the sensing element as it imbibes moisture from the surrounding waste. Issues in using such soil moisture sensors include:

- **Installation:** The sensors must be properly emplaced within waste to take up moisture and give a meaningful reading. Direct contact with even a slight amount

of moist waste may give a high "false positive." The sensor can be surrounded by about a 1-ft layer of soil, which transmits moisture to the sensor so that its reading best represents the average level in the surrounding waste.

- Percentage of moisture measurements: The sensors' capacitance (current flow under applied AC voltage) is an indirect indicator of the parameter of interest, percentage of moisture by weight, the parameter most frequently correlated with biological activity and methane generation. (Calibration can be done to correlate sensor reading with percentage of moisture, however.)
- Hysteresis: Once wet, sensors tend to remain wet. Thus, sensors are most useful for measuring moisture arrival at the sensor locations in waste.

An additional, general problem exists with all measurements that are carried out in situ (in the waste itself): electrical (or sometimes other types such as gas conducting) leads are required to serve sensors within waste. Leads and, to a lesser extent, the sensors themselves are subject to breakage. High forces on leads and breakage can occur as waste is compacted or, later, as waste subsides with decomposition.

Even with such limitations, moisture measurements within the waste can be of high value. Readings from a sensor can verify arrival of moisture at a given point in waste. Moisture readings from sensors arrayed in a network throughout the waste mass are good indications of whether leachate recycle or other hydration means are effective. Hysteresis may be a factor (and shorten sensor lifetime), but these are not great problems; verification of initial moisture arrival is most critical, as it is likely that, once wetted, waste will remain sufficiently wet for biological activity. The lead breakage problem can be addressed as discussed below.

### *Gas Flow Measurement*

Gas or methane generation (normalized in terms of volume per unit of dry waste) may be considered one of the best indicators of the progress of stabilization. The relative rate of generation—compared with typical landfill rates of 0.03 to 0.15 ft<sup>3</sup> methane per pound of waste per year (3 to 10 L/kg/yr)—indicates whether enhancement methods are successful in accelerating the normal rate of decomposition. The total cumulative generation—in turn a reflection of the mass of waste converted to gas—may be one of the best reflections of the degree to which stabilization is attained and, of course, of energy recovery.

Methods that may be applied to measure gas flow are shown in Table 2. It should be noted here that bioreactor landfill gas recovery measurements have been observed to be more demanding than such measurements with conventional landfills. The flow from bioreactor landfill sectors or cells may change rapidly, and variations of an order of magnitude or more (for various reasons) have been common (2-4). Figure 2 illustrates flow as measured from one test cell in the Mountain View, California, demonstration experiment. Similar fluctuations have been routine in other trials (4). "Conventional" landfill measurement approaches using infrequent, (say weekly) "point in time" measurements cannot accurately establish the rate of generation or the cumulative generation total of such a fluctuating gas flow. In addition, limited rangeabilities of common pressure-drop-based pitot tube and orifice methods (and venturi and turbine when used) cannot

accommodate order-of-magnitude flow-rate variations. Ideally, bioreactor landfill gas recovery flow monitoring should combine cumulative volume measurement with wide range and contaminant resistance. This would also allow correction for temperature and pressure variation, although such corrections are usually minor. No method combining all desirable features has yet been reported in a bioreactor landfill operation; however, there are methods that should work (e.g., a corrosion-resistant positive displacement meter with temperature/pressure compensation). It is also possible to combine two or more meters that rely on differing measurement principles for redundancy; agreement between two or more methods would strongly suggest accuracy.

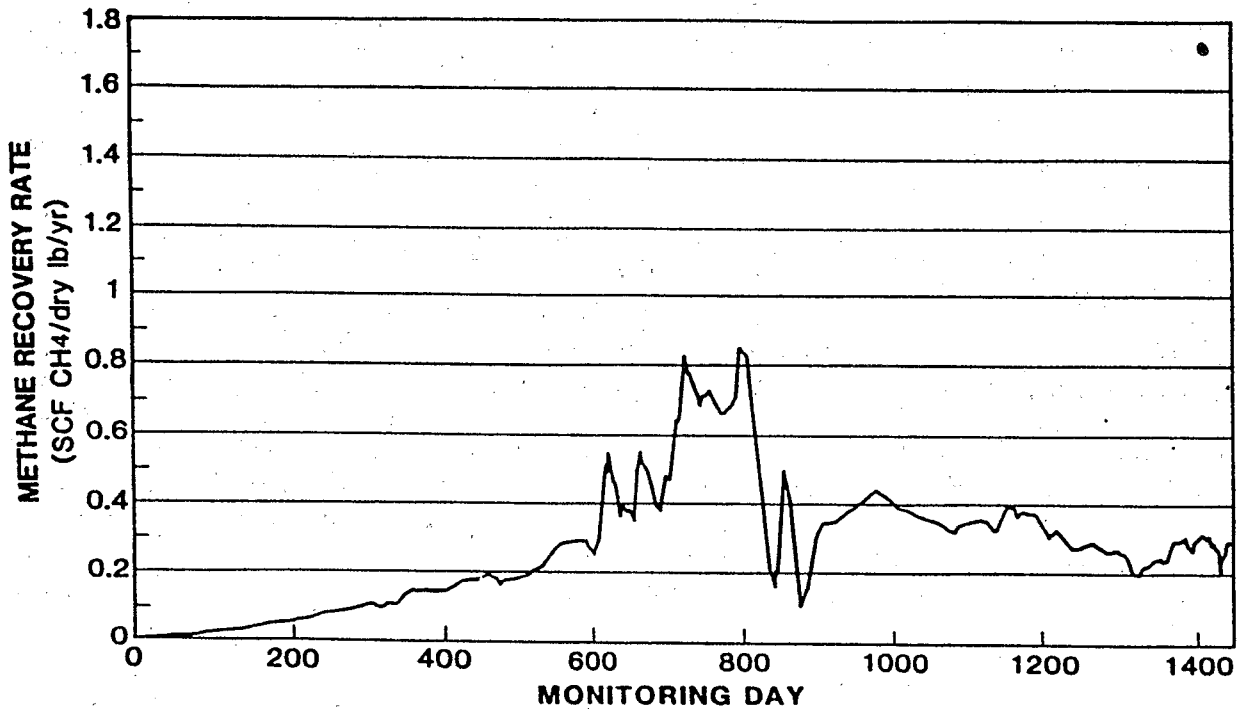

Figure 2. Gas recovery from Mountain View test landfill Cell F.

Though the flow of recovered gas may be measured accurately, generation is often the measurement actually desired. Generation measurement can still be negated by gas leaks. These can comprise either leakage of gas out through containment (surface clay or membrane) or, in some cases, infiltration of air or gas from the surroundings into the waste. (In fact, it appears that full recovery of gas has not been validated in any bioreactor landfill test to date—which among other things has limited material balance closures.) With some types of containment design, it should be possible to detect and compensate for leaks. Leaks may be detected, and size of leak estimated, by following air intrusion (i. e., exit gas  $N_2/O_2$ ) as pressure is varied under membrane covers; however, this does typically require a design permitting close submembrane pressure control, as in a porous sublayer. Once detected, repairs can be made. Alternatively, leak effects can be compensated for (to significant degrees if not completely) from pressure measurements combined with standard pressure/ flow relationships.

**Table 2. Methods for Assessing Gas Recovery (Flow Rate and Total Flow)**

| Method                | Turndown Ratio               | Contaminant Resistance | Accuracy of Reading (approx. limits, % of indicated reading) | Cumulation Possible | Comments   |
|-----------------------|------------------------------|------------------------|--|---------------------|--|
| Pitot tube            | Limited (4/1)                | Excellent              | +/-5 to 10%  | Normally no         | Simplest, most common field method                                   |
| Orifice               | Limited (ca. 4/1)            | Excellent              | +/-1 to 3%   | Yes <sup>a</sup>    | Common method—conventional landfills                                 |
| Venturi               | Limited (about 4/1)          | Excellent              | +/-1 to 2%   | Yes <sup>a</sup>    | --   |
| Vortex shedding       | Range (ca. 10/1)             | Excellent              | +/-1 to 5%   | Yes <sup>a</sup>    | --   |
| Thermal dispersion    | Range (ca. 10/1)             | Excellent              | +/-1 to 4%   | Yes <sup>a</sup>    | Gas composition may affect accuracy                                  |
| Turbine               | Range limited                | May be poor            | +/-1 to 5%   | Yes <sup>a</sup>    | Corrosion resistance needed; poor or absent in commercial versions   |
| Positive displacement | Excellent zero to full scale | May be poor            | +/-1%  | Yes <sup>b</sup>    | Corrosion resistance needed; poor or absent in commercial gas meters |

<sup>a</sup>Cumulation normally electronic.

<sup>b</sup>Cumulation can be electronic or mechanical; cumulative gas volume normally registered mechanically.

### *Gas Composition*

Gas composition measurements can be valuable in several respects. Methane/carbon dioxide ratio in recovered gas can indicate satisfactory biological reactions (CH<sub>4</sub>/CO<sub>2</sub> ratio of 1 or more suggesting satisfactory reaction progress; a ratio much less than 1 usually indicates an unsatisfactory or "startup" condition). Methane content and cumulative recovery are both of obvious importance in energy applications. Total methane generated per unit waste, as determined from composition and

cumulative flow, is also a good index of the degree of stabilization that has been accomplished. Hydrogen gas at detectable levels (greater than 1 percent) may also suggest problems with biological reactions. Nitrogen in recovered gas can indicate air intrusion from leaks, as by methods discussed above, or it can indicate air entrainment as conventional well extraction systems are "tuned." (Oxygen is a much less satisfactory indicator of air intrusion because it often tends to be consumed in the waste mass.)

In "conventional" landfill situations, methane is most often measured on the basis of gas thermal conductivity (TC). Because thermal conductivity of gas can depend on components in addition to methane, TC-based detectors are subject to a certain amount of error. Errors can occur from water vapor where high in saturated gas, or at methane concentrations substantially away from 50 percent or, in particular, when hydrogen is present in gas. In usual operating situations, however, with methane near 50 percent, the methane content is often found close, within 1 to 3 percent, to content as determined by precise means such as chromatography. Another type of detector works on the basis of infrared (IR) absorption bands of methane and carbon dioxide. These IR-based meters have significantly better accuracy for methane and CO<sub>2</sub> than TC-based meters, and some manufacturers' models combine gas composition measurement with other features useful in the field.

The drawback with both TC- and IR-based meters is their inability to measure nitrogen accurately. Gas other than CO<sub>2</sub>/CH<sub>4</sub> could be assumed (nitrogen + oxygen + water vapor). Such difference calculations provide a rough estimate of nitrogen at best, however. Accurate nitrogen content measurements can be important as indicator of leaks or air intrusion. Standard gas chromatography techniques are best for determining nitrogen; several manufacturers make units suitable for field use, and equipment is available that allows frequent automated analysis of the gas at chosen sampling points.

Note that gas composition may remain relatively stable for long periods in many situations. Landfill sectors or cells with well-established methanogenesis continue to generate gas with composition of about 52 to 55 percent methane and 45 to 48 percent CO<sub>2</sub> until decomposition is substantially complete. Recovered gas maintains this composition providing there is no air entrainment. Under such circumstances, it may be possible to assume constant composition with reasonable certainty and greatly reduce monitoring frequency.

#### *Temperature Determination in Filled Waste*

Temperature in waste importantly affects methanogenesis and other biological reactions (although it normally receives little attention as a bioreactor landfill variable). Methane fermentations appear to follow a classical Arrhenius reaction rate temperature dependence reasonably well; Figure 3 presents the Arrhenius plot of rate constant data from six different methane fermentation investigations (5) exhibiting an E<sub>a</sub> of about 15 kcal/mol. (Temperature's importance is illustrated by the rate constant's 50-fold increase between 10°C and 55°C.) Landfill core samples have shown similar temperature dependence for methane generation (6). What could be termed "thermal effects" can occur as waste is warmed by methanogenesis, which is exothermic, while at the same time temperature is lost by conduction from the fill (2, 3, 7). The exotherm of methanogenesis can be sufficient to warm waste to 55°C to 60°C, at which point methanogenesis may be inhibited. Important consequences are that different portions of the waste may decompose at substantially

different rates as temperature varies by locale; cooling may be necessary in situations where temperature can exceed 55°C to 60°C. Temperature monitoring can be useful in identifying these situations.

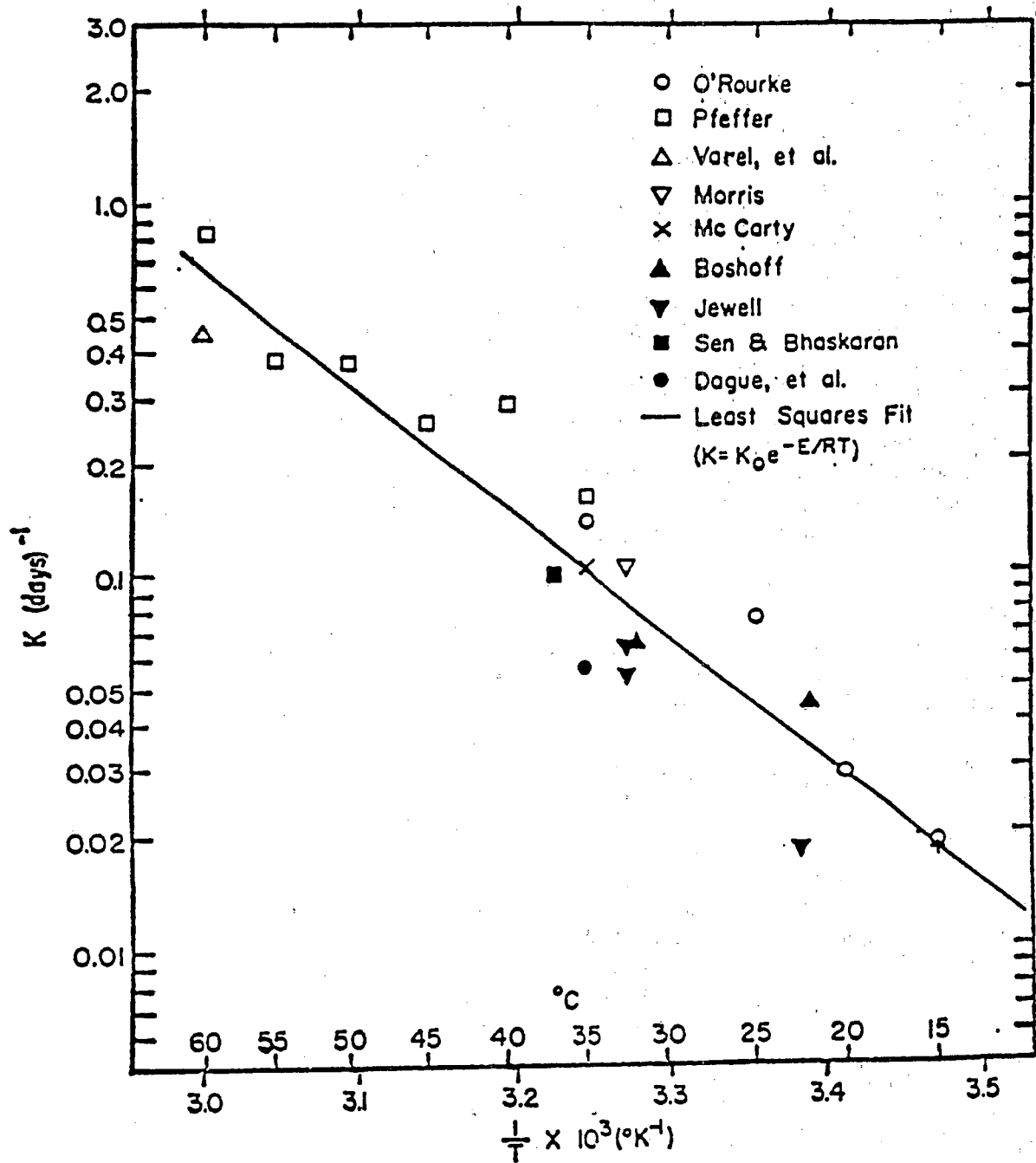

Figure 3. Arrhenius plot showing temperature dependence for methane fermentations of solid substrates (5).

Sensing temperature is generally straightforward using thermocouples or thermistors. Temperature and moisture sensing are easily combined at locations within the waste. The principal problem with temperature sensing within the waste, common to all sensing within the waste, is lead protection, discussed below.

### *Leachate Composition and Flow Rate*

Leachate composition and characteristics can reflect whether conditions are suitable for biological reactions or whether there are situations needing attention. Leachate should be at near-neutral pH. The principal concern would be high levels of organic acids and low pH (below about pH 6). These indicate "stuck" conditions that can inhibit methanogenesis. Such conditions, if more than transitory, require remedial action—by base addition, or withdrawal and recirculation/redistribution of acidic leachate through the waste. (Either approach should normally facilitate methanogenesis.) Other characteristics of leachate may be considered important in given situations. Alkalinity reflects the capability of leachate to buffer organic acids that may be formed in intermediate steps of decomposition. Nutrients, such as phosphate and free ammonia, may be of interest. Nutrients in waste appear normally to be at least minimal levels needed for decomposition. Supplementation may still be desired, however, and analyses of free nutrient levels in leachate indicate whether supplementation may be useful. (Leachate nutrient levels might also be correlated with rates of waste degradation in experimental situations.) Leachate biochemical oxygen demand (BOD) and organic acids are of environmental significance, as these reflect threats posed to ground water. Still other characteristics of leachate may also be of interest—assays for inhibitory activity of leachate may be important in cases where methane generation slows for unknown reasons.

pH measurements of leachate outflows (from waste sectors of interest) are easily made at the time and point of collection. (As noted, pH below about 6 indicates possible "stuck" [i.e., acid inhibited] conditions.) Other assays are typically more demanding. Organic acids are best assayed by gas chromatographic methods. Phosphate, ammonia nitrogen, BOD, and other assays that may be desired are standard wastewater tests. Biological methane potential assays can show toxic or inhibitory conditions. Assays can be performed soon after collection (holding time minimized to limit associated composition changes). In some cases, however, it may be convenient to freeze samples on collection (which halts composition changes) until a number of samples can be assayed simultaneously.

Leachate flow rate can be measured in several ways. In many cases, flows can be estimated from level changes as holding tanks of one sort or another fill with outflowing leachate or empty as leachate from them is recirculated. A number of fouling-resistant flow measuring techniques are available including tipping bucket and magmeters, but there are few reports of actual long-term leachate flow rate measurements.

### *Waste Sampling and Measurements*

Waste characteristics important in bioreactor landfill situations can include moisture content, cellulose and other decomposable content, lignin and other nondecomposable content, ash, nutrients, and bacterial populations. These parameters can in turn be important for purposes including development of material balances, estimating methane potential, and estimating needs for

supplemental moisture or nutrients. One important sampling objective in past tests has been to determine the remaining methane potential of waste in landfills that are decomposing.

Probably the single greatest difficulty with waste sampling is posed by heterogeneity of waste. Significant batch-to-batch variations in waste arriving at the landfill may occur by season, area from which the waste was collected, etc. There will be variations in composition with location within the fill; reasons for in-fill variations include not only the mentioned variations in incoming waste but also hydraulic effects (liquid preferentially infiltrating or accumulating in certain areas). Waste characteristics in the fill may become even more variable with location and over time, as decomposition of either wetter or warmer waste is more rapid than slower and drier elements. (See above. In fact, it is an open question as to whether it is appropriate to refer to "the" waste composition in light of such variation.)

With all of the waste variability, however, the objective of sampling is often simply to determine an overall average of parameters within a given body or stream of waste. (The purposes, for example, include determining the degree of decomposition that has occurred and total methane potential that remains in the mass of waste.) Sampling can be carried out at multiple points to obtain the best possible "average" composition. Samples from corings should be taken at multiple levels. Samples from several locations may be ground and assayed for the average of the parameter desired.

#### *Hydrostatic Head*

Bioreactor landfills must operate in conformance to regulations affecting landfills. Perhaps the greatest regulatory concern with bioreactor landfills relates to increased moisture. Under current U.S. regulations, under elevated moisture conditions, hydrostatic head at the landfill base must nonetheless be kept below 30 cm to minimize the threat of ground-water contamination. Some state and local regulations may be more stringent (in the United States, California regulation requires "zero" head). Ground-water contamination concerns also exist in most other countries, although details of regulations may differ.

Hydrostatic head can be determined by differential pressure measurements, most commonly using transducers. Pressure at the base of the landfill must be compensated for gas pressure to get the true liquid head. Pressure can be measured at the base of the landfill and at elevations from one to several feet above the base. Pressure versus height measurements allow differentiation of the head, which is due to liquid (hydrostatic), and which is of regulatory concern, from the pressure component due to gas.

#### *Waste Volume Reduction*

By increasing waste-to-gas conversion, bioreactor landfill operation can substantially reduce landfilled waste volume. Lessened waste volume could be of major importance, insofar as it can translate into greater capacity of the landfill to accept waste for any given waste volume or height. Volume reduction can be straightforwardly followed by tracking subsidence of surface monuments, as practiced in past tests (3).



### *Placement of In-Waste Sensors and Lead Protection*

In past field-scale demonstrations, moisture, temperature, and other sensors have typically been placed in waste by either of two routes: (a) insertion in pipes within vertical boreholes drilled after waste is filled, or (b) placement within waste as waste is filled. With the first route, leads within pipes are well protected and sensor replacement is possible. This process can be costly, however, and sealing of the well used to place the sensor may be a concern. Better contacting for moisture sensors can be afforded by the second route. With this route (i.e., placement within waste as filling occurs), horizontal lead wires to the sensors need to be protected during and after filling of the waste. Breakage may occur with compaction after sensors are placed or at later times as waste subsides with decomposition. The majority of landfill bioreactor tests appear to have experienced some loss of in situ sensors. In some cases, losses of some types of sensors with horizontal lead placement have been total.

Lead breakage can be reduced by enclosure of leads in rugged tubing or pipe. Preliminary tests (8) have shown that among candidate protective pipe (including flexible agricultural drainage and other types) flexible PVC fiber reinforced tubing best protects leads. Chances of breakage in leads can be further reduced by allowing 50 percent more tubing than the straight distance to accommodate for settlement. Further slack in the sensor lead—relative to the protective tube—can help ensure that any stresses are borne by the tube rather than the lead.

### *Computerized Data Collection and Processing*

A complex system such as a landfill bioreactor can now benefit from real-time monitoring, data collection, and control. Recent advances in software and decreases in the cost of microprocessor instrumentation and controls now enable collection of various outputs and data from a variety of sensors simultaneously using a personal computer. The same software can control operations and further process archived data. The software has been developed for use in such applications as monitoring and control of heating, ventilating, and air conditioning (HVAC) systems and control of chemical processing trains. It appears quite adaptable to the needs associated with bioreactor landfill operation as well. A supervisory control and data acquisition (SCADA) system typically consists of a host computer linked to a remote telemetry unit (RTU) located at the landfill bioreactor site. It can collect and archive real-time data and perform control operations. Data collected at the landfill bioreactor and relayed by the RTU to the host computer can be displayed to observe trends and archived for future analysis.

### **Conclusion**

This paper has provided a brief overview of some measurements that may be useful in monitoring and control of landfill bioreactors. Readers should recognize that other measurements are possible, and issues exist that were not covered above. (Further discussion and information on the various possible measurements is also contained in "Experimental System Instrumentation" by Dr. D.J.V. Campbell. An expert working group paper was prepared for the International Energy Agency in 1994 [9].) Bioreactor landfill technology is still developing. Where parameters were discussed, it should be recognized that optimum values for various parameters (e.g., nutrients, pH) in many respects remain to be established.

## References

1. Halvadakis, C.P, A.P. Robertson, and J.O. Leckie. 1983. Landfill methanogenesis: Literature review and critique. Technical Report 271. Civil Engineering Department, Stanford University, Palo Alto, CA.
2. Augenstein, D., J. Pacey, R. Moore, and S.A. Thorneloe. 1993. Landfill methane enhancement. Proceedings of the 1993 Annual International Landfill Gas Conference, Solid Waste Association of North America (SWANA), Silver Spring, MD.
3. Pacey, J., J.G. Glaub, and R.E. Van Heuit. 1987. Results of the Mountain View controlled landfill project. Proceedings of the Governmental Refuse Collection and Disposal Agency (GRCDA) 1987 Landfill Gas Conference, Solid Waste Association of North America (SWANA), Silver Spring, MD.
4. Campbell, D.J.V. 1991. Landfill gas enhancement: Brogborough test cell programme. Proceedings of the SWANA 14th Annual International Landfill Gas Symposium (March).
5. Ashare, E., D.L. Wise, and R.L. Wentworth. 1977. Fuel gas production from animal residue. Dynatech R/D Company Report 1551, final report under U.S. Department of Energy Contract EY-76-C-02-2991. Available from NTIS.
6. Hartz, K.E., R.E. Klink, and R.K. Ham. 1982. Temperature effects: Methane generation by landfill samples. J. Environ. Eng.
7. Rees, J.F. 1980. Optimization of methane production and refuse decomposition in landfills by temperature control. J. Chem. Technol. and Biotech. 30.
8. Institute for Environmental Management. Yolo County, California, Landfill Methane Enhancement Project, Palo Alto, CA (in progress).
9. Campbell, D.J.V. 1994. Experimental system instrumentation. Expert working group paper prepared for International Energy Agency.

## **Long-Term Permeability of Granular Drainage Material**

---

George R. Koerner and Robert M. Koerner

Geosynthetic Research Institute, Drexel University, Philadelphia, Pennsylvania

---

### **Abstract**

The leachate collection system at the base of a landfill must function over its design lifetime irrespective of the liquids management strategy being used. The two liquids management options in this regard are (a) leachate removal followed by disposal on demand, or (b) leachate recycling. Both practices cause concern over excessive clogging of the filter placed above the drainage. As a result, some designs call for the elimination of the filter entirely. In such cases, select waste is placed directly on the granular drainage material.

This paper experimentally investigates the situation of municipal solid waste leachate flowing through select waste that is placed directly on various gravel or sand soils. Eight long-term tests have been evaluated using four different gravels and four different sands. The permeability tests have been performed for 800 to 1,000 days. Results indicate that the drainage soil permeability comes to equilibrium, and this type of "no filter" practice can be used. Use of this no filter strategy, however, must be preceded by long-term laboratory tests using the site-specific materials (i.e., waste, drainage material, and leachate). In the absence of such tests, the use of a geotextile filter over the entire footprint of the base of the landfill is a more conservative design strategy.

### **Introduction**

Located at the bottom of the landfill, a leachate collection and removal system (LCRS) consists of a drainage layer (sand, gravel, geonet, or geocomposite) with a filter above it (usually) and a perforated pipe system within it. The pipe system leads to a sump, which is accessed by a manhole or sidewall pipe riser from which the leachate is removed.

The filter material placed above the drainage media of an LCRS cannot experience excessive clogging during the design life of the facility. Some degree of clogging is to be expected. A limited amount of clogging can occur, however, without adversely affecting the drainage system, at least until it begins "starving" the underlying drainage material. At that point, leachate begins to build up into the solid waste. The implication of such "perched leachate" is quite unknown but certainly is not desirable. In the extreme case, a bathtub is formed and leachate may exit the sides of the facility in the form of sidewall or cover seeps. Importantly, if leachate recycling is the liquids management strategy at the facility, this situation is aggravated due to the constant reintroduction of leachate back into the top of the waste mass. Leachate recycling may simply not work if the filter becomes excessively clogged. Hence, "excessive clogging" should be the concern when using filters above the various types of drainage materials in the LCRS.

---

## Sources of Clogging

The filter zone above the leachate collection system is the optimal location for clogging from several sources. These sources include particulate, biological, and precipitate clogging. The range of leachate characteristics presented in Table 1 is such that particulates, microorganisms, and precipitates are all common to municipal solid waste (MSW) leachates.

Table 1. Range of Leachate Characteristics (1)

| Potential Clogging Mechanism | Property of Concern             | Range of Values (mg/L) |
|------------------------------|---------------------------------|------------------------|
| Particulate                  | pH                              | 3.7 - 8.5 <sup>a</sup> |
|                              | Total solids (TS)               | 0 - 59,200             |
|                              | Total dissolved solids (TDS)    | 584 - 44,900           |
|                              | Total suspended solids (TSS)    | 10 - 700               |
| Biological                   | Chemical oxygen demand (COD)    | 40 - 89,520            |
|                              | Biochemical oxygen demand (BOD) | 81 - 333,360           |
|                              | Total organic carbon (TOC)      | 256 - 28,000           |
| Precipitate                  | Specific conductance            | 2,810 - 16,800         |
|                              | Alkalinity (CaCO <sub>3</sub> ) | 0 - 20,800             |
|                              | Hardness (CaCO <sub>3</sub> )   | 0 - 22,800             |
|                              | Total phosphorus                | 0 - 130                |
|                              | Ammonia                         | 0 - 1,106              |
|                              | Nitrate                         | 0.2 - 10.29            |
|                              | Calcium                         | 60 - 7,200             |
|                              | Chlorine                        | 4.7 - 2.467            |
|                              | Sodium                          | 0 - 7,700              |
|                              | Sulfate                         | 1 - 1,558              |
|                              | Manganese                       | 0.09 - 125             |
| Magnesium                    | 17 - 16,600                     |                        |

<sup>a</sup>All are in mg/L, except pH, which is in pH units.

**Particulate clogging** is rather self-explanatory. It is the settling out of suspended particles from the leachate. Particulate clogging generally occurs at the upper surface of a filter. This is sometimes referred to as formation of a surface filter cake. In contrast to this surface phenomenon, depth filtration may also occur, in which successively smaller particles in the leachate are removed from suspension within the thickness of the filter. The mechanism of depth filtration incorporates embedment of suspended particles from the leachate in the pores of the filter. In so doing, the sediment that collects within the filter acquires a gradation of large to small particles. It has been shown that depth filtration is more conducive to fluid flow than is cake filtration.

The clogging associated with **biological growth** is very complex. It occurs when microorganisms metabolize in and around the filter material. Biological growth depends on the presence of microorganisms, appropriate nutrients, and environmental conditions that sustain growth. Factors felt to influence biological clogging include carbon-to-nitrogen ratio of the leachate, rate of nutrient supply, concentration of polyuronides, moisture conditions of the waste mass, and temperature.

Anaerobic rather than aerobic conditions prevail in most locations in a landfill. Hence, methanogenic bacteria are most prevalent. The quantity and quality of nutrients available to the methanogenic bacteria are significant in this metabolism. Nutrients required by methanogenic bacteria include carbon, hydrogen, oxygen, nitrogen, and phosphorous. In addition, they require limited concentrations of trace metals such as sodium, potassium, calcium, and magnesium. Biofilm growth starts on the surface of the filter media and eventually incrusts it. Upon incrusting the media surface, it then moves into the pore spaces and reduces flow through the filter.

Current practice at many landfills is to codispose sewage treatment plant sludge and MSW. This practice ensures the presence of a population of methanogenic bacteria as well as the nutrients needed for them to metabolize. In addition, leachate recirculation is being practiced at a number of landfills. Leachate recirculation makes a "bioreactor" of the landfill and promises to encourage degradation of the waste mass by continuously recasting leachate into the waste. This practice further ensures the presence of a population of viable microorganisms to degrade the waste mass and potentially cause excessive clogging of the filter of the leachate collection system.

The final type of clogging is associated with **chemical precipitation**. It occurs as a result of chemical processes that include the precipitation of calcium carbonate, manganese carbonate, and other insoluble forms such as sulfides, chlorides, and silicates. Inorganic chemical precipitates can form when the pH exceeds 7. Hardness and total alkalinity of the leachate are also important. Precipitation can be caused by the presence of oxygen, changes in pH, changes in the partial pressure of carbon dioxide, or evaporation of residual liquid. Biochemical precipitation can also exist. The biochemical mechanisms usually involve the complexation of iron or manganese. The most frequently complexed metal is free, which results in the formation of "ochre" deposits.

Both inorganic precipitate and biochemical precipitate clogging are iterative and sometimes synergistic. When conditions are right, precipitate clogging can quickly decrease the permeability of a filter. A modified list of precipitate clogging indicator parameters appears in Table 2.

### **Filter Design and Performance**

Inasmuch as the previously described clogging sources are complex and indeed of concern, the field verification of such excessive clogging phenomena is quite sparse. Due, however, to the growing interest in leachate recycling and interest in conventional liquids management

**Table 2. Indicators of Precipitate Clogging Parameters (2)**

| <b>Corrosive Condition</b>   | <b>Incrusting Condition</b>   |
|--|---|
| At pH less than 7  | At pH greater than 7  |
| Dissolved oxygen in excess of 2 mg/L   | Total iron (Fe) in excess of 2 ppm  |
| Hydrogen sulfide (H <sub>2</sub> S) in excess of 1 mg/L  | Total manganese (Mn) in excess of 1 mg/L in conjunction with high pH and the presence of oxygen |
| Total dissolved solids in excess of 1,000 mg/L, indicating an ability to conduct electric current great enough to cause electrolytic corrosion | Total carbonate hardness in excess of 300 mg/L  |
| Sulfate in excess of 300 mg/L  |   |
| Carbon dioxide (CO <sub>2</sub> ) in excess of 50 mg/L   |   |
| Chloride in excess of 500 mg/L   |   |

strategies at landfill sites, the U.S. Environmental Protection Agency (EPA) has funded a major effort to assess leachate collection filter clogging. In a recently concluded three-part study consisting of field investigations, long-term laboratory testing, and design model formulation, the following formulas were developed to arrive at a flow rate factor of safety (4-7). The formulas were developed specifically for filters of drainage systems at the base of a landfill.

$$FS = \frac{k_{allow}}{k_{reqd} \times DCF} \text{ or} \tag{1a}$$

$$FS = \frac{\Psi_{allow}}{\Psi_{reqd} \times DCF} \tag{1b}$$

where

- FS = factor of safety against excessive long-term filter clogging
- k<sub>allow</sub> = allowable permeability
- k<sub>reqd</sub> = required permeability
- DCF = drain correction factor
- Ψ<sub>allow</sub> = allowable permittivity
- Ψ<sub>reqd</sub> = required permittivity

Equations 1(a) and 1(b) are equivalent relationships since:

$$\Psi = k/t \quad (2)$$

where

$t$  = filter thickness (usually a geotextile)

The values of  $k_{\text{allow}}$  (or  $\Psi_{\text{allow}}$ ) are obtained from laboratory tests using the candidate geotextile filter and site-specific leachate at the anticipated flow rate. It should be noted that natural soil filters can be evaluated in exactly the same manner. The value of  $k_{\text{reqd}}$  (or  $\Psi_{\text{reqd}}$ ) is obtained via a computer code using site-specific hydraulic information and solid waste characteristics. The EPA-sponsored Hydrologic Evaluation of Landfill Performance (HELP) model is typically used in this regard. The value of DCF is obtained from the site-specific layout of the geotextile filter with respect to the underlying drainage and removal system. The DCF is defined as the landfill cell area divided by the available area for flow into the drain.

The laboratory portion of the above referenced study (7) included three different MSW leachates and distilled water (as the control) using 10 geotextiles and 2 soil filters. The resulting 144 test columns were made in accordance with the ASTM D1987 test method. Each column was permeated at fast, medium, and slow flow rates for a minimum of 200 days until an equilibrium permeability was established.

Using Equation 1(a) with site-specific, required permeability values and geotextile-specific allowable permeability values for four exhumed field sites (6), the information in Table 3 was generated. In reviewing the table, it is clear that the failures could have been readily predicted, as well as the one success of the site that was still functioning.

**Table 3. Use of the Newly Modified Factor of Safety Equation as Applied to Four Exhumed Field Sites**

| Site No. | Observed Performance | $k_{\text{allow}}$<br>cm/sec | $k_{\text{reqd}}$<br>cm/sec | DCF    | Calculated FS | Predicted Performance |
|----------|----------------------|------------------------------|-----------------------------|--------|---------------|-----------------------|
| 1        | Terrible             | $6 \times 10^{-4}$           | $1 \times 10^{-5}$          | 24,000 | 0.0003        | Failure               |
| 2        | Good                 | $1 \times 10^{-2}$           | $1 \times 10^{-5}$          | 140    | 7.0           | Acceptable            |
| 3        | Terrible             | $9 \times 10^{-3}$           | $5 \times 10^{-4}$          | 990    | 0.02          | Failure               |
| 4        | Poor                 | $9 \times 10^{-3}$           | $5 \times 10^{-5}$          | 1,700  | 0.1           | Failure               |

## "No Filter" Strategy

The authors believe that by using a geotextile filter over the entire footprint of a landfill an acceptable long-term strategy for a leachate collection system in a modern landfill will result. Some designers are using the option of "no filter," however. With this strategy, the waste is placed directly on the drainage material, which is either gravel or sand. The logic of this design strategy is that the filter contains the smallest voids, which are most likely to experience excessive clogging. If entirely removed, the likelihood of drainage material clogging is distinctly lessened. Furthermore, by using gravel as the drainage material instead of sand (and even large-size gravel), the likelihood is even further reduced.

The thought of using no filter in the leachate collection system leads to some concern about problems with soil loss or piping. In this regard, field pump tests conducted at several different landfills by Oweis (8) suggest that the permeability of MSW is typically  $10^{-2}$  to  $10^{-4}$  cm/sec. Hence, a proper design balances the properties of flow capacity and particle retention. In the no filter scenario, the permeability of the drainage material is near that of the MSW but still capable of retaining the relatively large particles of the waste.

Indeed, the no filter strategy is presently being practiced at several landfills. In all cases, the waste placed over the drainage media is considered "select waste." As such, no large objects are allowed in the select waste. This precaution is taken to prevent penetration of the drainage material and puncture of the underlying liner system.

## "No Filter" Experiments and Results

The experimental investigation presented in this paper involved evaluating the permeability of eight different drainage materials over an extended period to determine (a) if an equilibrium flow rate existed, and (b) what its value was. The test method used was in accordance with ASTM D1987. The tests were conducted using rigid wall permeameters of 100-mm diameter, and flow rates were measured under constant head conditions. The resulting permeability values were calculated using Darcy's formula at incremental periods throughout the duration of the tests. Each of the flow columns was permeated with MSW leachate at a flow rate of 20,000 l/ha-day. This flow rate was chosen on the basis of a New York State survey of its landfills, which found that average leachate flow rates are approximately 19,000 l/ha-day (2,000 gal/acre-day) (9). All tests were conducted under saturated anaerobic conditions, and gas production was noted in all eight columns.

The experimental design consisted of eight flow columns. Figure 1(a) shows a photograph and Figure 1(b) a schematic diagram of the test setup. Four of the permeameters contained different types of gravel underneath the waste, and an additional four of the columns had different types of sand underneath the waste.

The solid waste and the leachate were obtained from a local MSW landfill. The solid waste was excavated out of a region of the landfill that was saturated with leachate for approximately 2 years. It should be noted that some of the larger pieces of MSW were cut to fit inside the flow columns so they could be compacted into the 100-mm diameter flow permeameters.



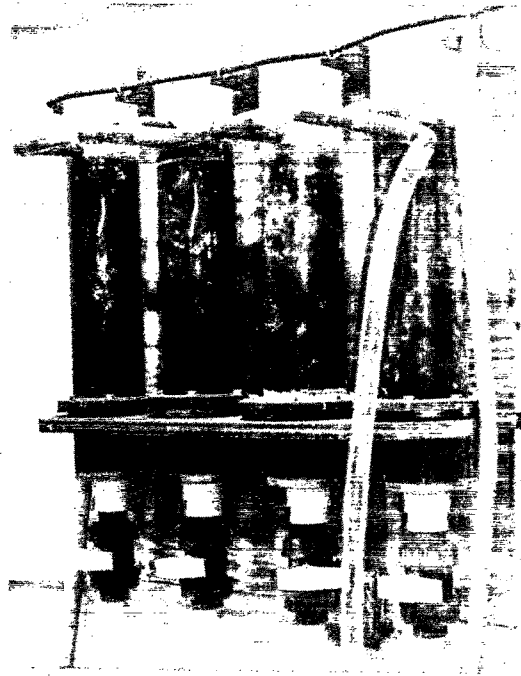

(a) Photograph of a set of four long-term flow permeameters.

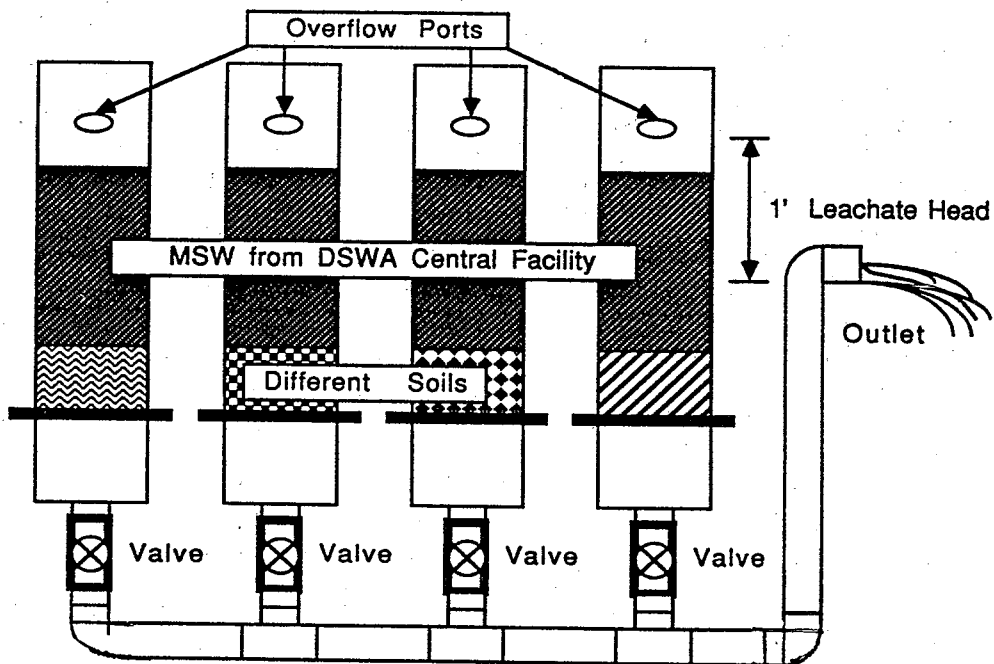

(b) Schematic diagram of a set of four long-term flow permeameters.

Figure 1. Long-term flow permeameters used for the testing of MSW placed directly above granular soils without the use of sand or geotextile filters.

Figure 2 presents the particle size distribution curves of the eight drainage soils selected for this study. They cover a wide range of particle sizes and gradations. Table 4 is presented to further characterize the various soils. Note that all are granular soils with relatively high permeability. The rationale in selecting these particular soils was that in formulating the draft EPA Leak Detection Rules (3), the requirement of a minimum 1.0-cm/sec permeability drainage material was regularly discussed. The four gravels selected for this study meet this criterion. All are poorly graded gravels (GPs) under the Unified Soil Classification System. They conform to sizes between American Association of State Highway and Transportation Officials (AASHTO) sizes #3 and #57. The mineral compositions of the four soils were selected on the basis of the most prevalent type of quarried stone. Thus, quartz, gneiss, limestone, and shale gravels are all included in the study.

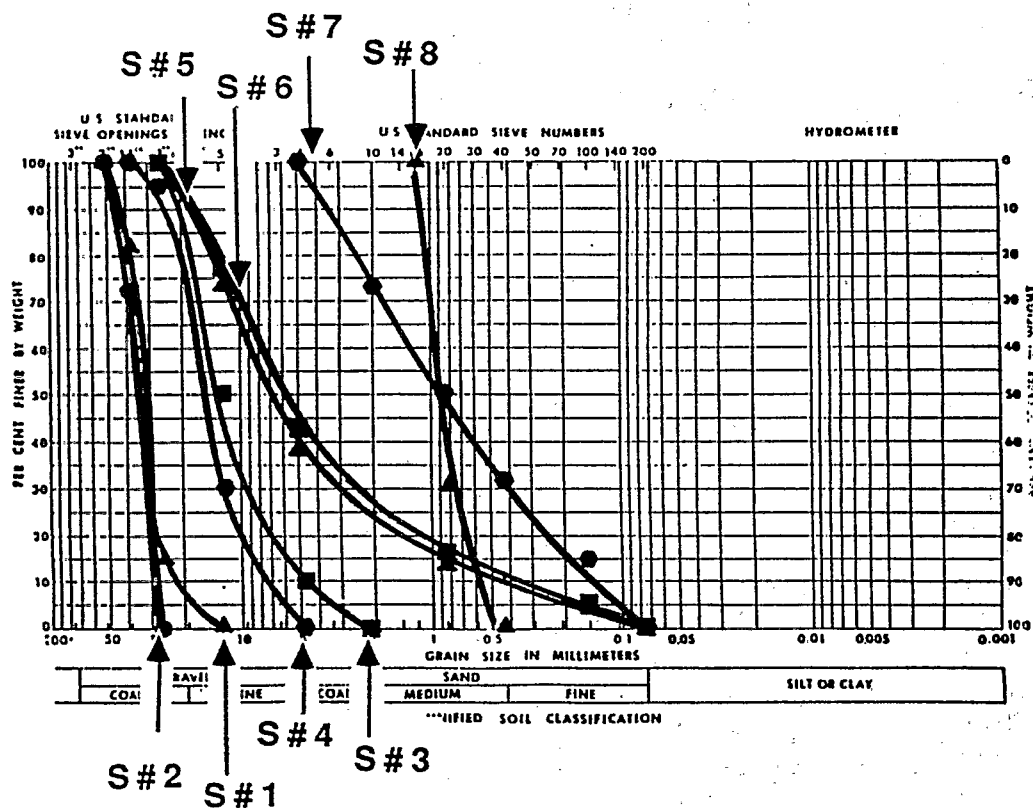

Figure 2. Particle-size distribution curves of eight soils used in this study.

When the Leak Detection Rules (3) finally appeared in the *Federal Register* in spring 1992, the permeability requirement remained at the previously regulated value of 0.01 cm/sec. Thus, the need arose for an additional four columns using sand as the drainage material. Again, limestone and quartz sandy soils were selected. Both materials are classified by the Unified Soil Classification (USC) system as well-graded sands (SW) and are designated as AASHTO #2A materials. In addition to these two well-graded sands, concrete sand and Ottawa sand were selected to investigate other alternatives. The concrete sand is classified as

**Table 4. Granular Soil Characteristics for "No Filter" Permeability Study**

| Column | Soil Type | Mineral   | Shape   | $d_{10}^a$<br>(mm) | $d_{50}^b$<br>(mm) | $d_{60}^c$<br>(mm) | CU <sup>d</sup> | USC <sup>e</sup> | AASHTO <sup>f</sup><br>Classifi-<br>cation |
|--------|-----------|-----------|---------|--------------------|--------------------|--------------------|-----------------|------------------|--|
| 1      | Gravel    | Quartz    | Rounded | 17                 | 32                 | 34                 | 2.0             | GP               | 3  |
| 2      | Gravel    | Gneiss    | Angular | 27                 | 33                 | 36                 | 1.3             | GP               | 3  |
| 3      | Gravel    | Limestone | Angular | 5                  | 16                 | 17                 | 3.4             | GP               | 57   |
| 4      | Gravel    | Shale     | Angular | 8                  | 17                 | 17                 | 2.1             | GP               | 57   |
| 5      | Sand      | Limestone | Angular | 0.4                | 7                  | 9                  | 22.5            | SW               | 2A   |
| 6      | Sand      | Quartz    | Angular | 0.4                | 6                  | 8                  | 20.0            | SW               | 2A   |
| 7      | Sand      | Quartz    | Angular | 0.2                | 0.9                | 1.4                | 8.5             | SW               | 10   |
| 8      | Sand      | Quartz    | Rounded | 0.6                | 0.9                | 1.0                | 1.7             | SP               | N/A (Ottawa)                               |

<sup>a</sup> $d_{10}$  = grain size of 10 percent finer by weight.

<sup>b</sup> $d_{50}$  = grain size of 50 percent finer by weight.

<sup>c</sup> $d_{60}$  = grain size of 60 percent finer by weight.

<sup>d</sup>CU = coefficient of uniformity =  $d_{60}/d_{10}$ .

<sup>e</sup>USC = Unified Soil Classification.

<sup>f</sup>AASHTO = American Association of State Highway and Transportation Officials.

an SW in the USC system and #10 in the AASHTO system. The Ottawa sand is classified as poorly graded sand (SP) in the USC system and does not fall under any designation in the AASHTO classification system.

Figures 3(a) and (b) show the graphed results of the system permeability for the eight permeameters. The gravel permeameters have been maintained for nearly 1,000 days, while the sand permeameters have been maintained for nearly 800 days. The results of the gravel permeameters shown in Figure 3(a) indicate that the MSW is definitely the controlling flow material. There is very little difference in system permeability due to particle shape, gradation, or mineral composition of the different gravels. In addition, the system permeability is remaining relatively constant for all four gravel columns. The slight rise in permeability after 200 days is explained as the start of a trend of piping and/or loss of fines. Because the permeameters are not recharged with MSW, this could eventually lead to further increases in permeability.

The results of the sand permeameters shown in Figure 3(b) indicate that the MSW is again dominating the flow. The permeability values are in the 0.01- to 0.001-cm/sec range, which is lower than expected for the sands alone. Laboratory results indicate that the sands by themselves have a permeability approximately equal to 0.1 cm/sec. A trend exists in all of the sand flow columns that suggests that the system permeability is decreasing over time. This decrease is not pronounced or sudden, but it is definitely observable.

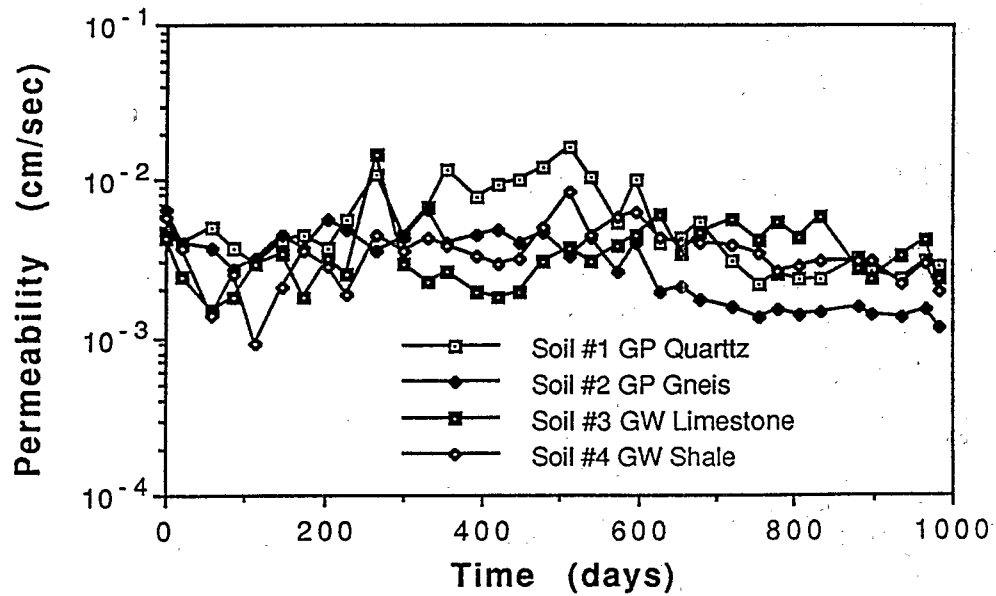

(a) Results using gravels beneath MSW.

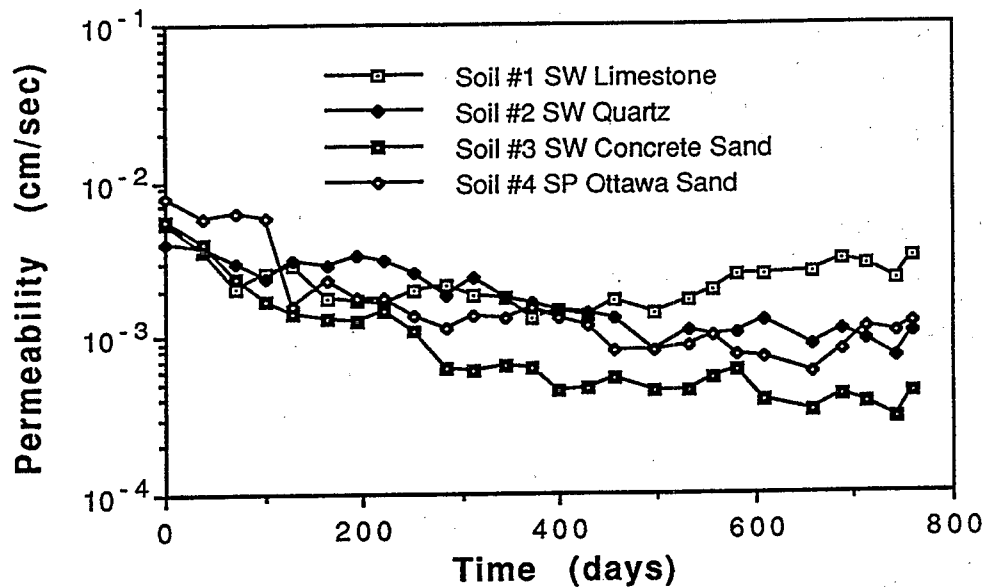

(b) Results using sands beneath MSW.

Figure 3. Long-term flow results per ASTM D 1987.

In addition to the information presented, the solid waste placed directly on drainage soils was qualitatively analyzed. The flow columns used for this study were made from acrylic, which is transparent. In the case of the gravels, it appears that small amounts of fines were migrating through the gravel over time. In the sand columns, there was staining of the MSW sand interface. Additionally, a qualitative observation can be made about the columns in which limestone aggregate was used. In all cases where limestone was used, it had not agglomerated together after being permeated with leachate for 800 days. Thus, the limestone used in these tests had not bound together via a reaction with the leachate. It is believed that the limestone in this experiment was of a low carbonate content (5 percent) and did not react with the leachate to any appreciable degree. Daniel and Koerner (10) suggest that such a reaction begins to occur only when carbonate contents are higher than 25 percent in the drainage material.

### Summary

Landfills are complex and constantly changing bioreactors. As such, a designer is faced with the challenge of designing a leachate collection system for changing conditions. Each stage of the evolution involves different processes, mechanisms, reactions, and microbes. Some conditions are short-lived, and others are nearly permanent. A designer needs to establish the worst-case scenario, or critical condition, during this evolutionary process and design accordingly.

### Acknowledgment

The knowledge and information contained in this paper were gained while working on a project funded by the U.S. EPA under cooperative agreement number CR-819371 entitled "Leachate Clogging Assessment of Geotextile Landfill Filters." The project officer was Robert E. Landreth. The financial assistance and cooperation of the Agency and its personnel are sincerely appreciated.

### References

1. Chian, E.S.K., and F.B. deWalle. 1976. Sanitary landfill leachate and their treatment. ASCE J. Environ. Eng. Div. 102(EE2): 411-431.
2. Driscoll, F.G. 1986. Groundwater and wells. St. Paul, MN: Johnson Division.
3. U.S. EPA. 1992. 40 CFR Parts 260, 264, 265, 270, and 271. Federal Register 57(19): 3,463.
4. Koerner, R.M., and Koerner, G.R. 1991. Landfill leachate clogging of geotextile (and soil) filters. EPA/600/2-91/025 (NTIS PB91213660). Springfield, VA.

5. Koerner, G.R., and R.M. Koerner. 1992. Leachate flow rate behavior through geotextile and soil filters and possible remediation methods. *J. Geotextiles and Geomembranes*. 11(6): 495-523.
6. Koerner, G.R., R.M. Koerner, and J.P. Martin. 1993. Field performance of leachate collection systems and design implications. In: *Proceedings of the 31st SWANA Conference, San Jose, CA*. pp. 365-380.
7. Koerner, G.R., R.M. Koerner, and J.P. Martin. 1994. Design of landfill leachate collection filters. *ASCE J. Geotech. Eng.* 120(10): 1,792-1,803.
8. Oweis, I.S., et al. 1990. Hydraulic characteristics of municipal refuse. *ASCE J. Geotech. Eng.* 116(4): 53.
9. Phaneuf, R. personal communication.
10. Daniel, D.E., and R.M. Koerner. 1993. EPA TGD: Quality assurance and quality control for waste containment facilities. CACR-815546-01-0. Cincinnati, OH.

## **Municipal Solid Waste Landfill Bioreactor Technology: Closure and Postclosure Issues**

---

Jerome J. Leszkiewicz

Leszkiewicz Consulting International, Inc., Rockville, Maryland

Peter B. McAulay

Northern Disposal Systems, Ltd., Auckland, New Zealand

---

### **Introduction**

The biodegradation of municipal solid waste (MSW) is accomplished in landfills when the moisture content of the refuse increases a sufficient amount in the presence of microorganisms to promote biological activity. In modern, lined landfills, the only source of additional water after refuse placement is from infiltration of precipitation and snowmelt through the landfill surface. In the past, this process occurred continually during the active life of the landfill and also after closure. It was generally believed, however, that once the moisture content of the refuse reached field capacity, ample moisture would be present to promote vigorous microbial activity in the waste. It was also generally assumed that once field capacity was reached, the waste would always remain at that moisture content, like a swollen sponge that would continue to hold on to all the water that it absorbed.

Most landfills are known to generate increasing amounts of leachate during operation, as older portions of the fill progressively begin to reach field capacity. Channelized flow of infiltration within the fill also contributes to early leachate generation and discharge from the landfill. The quantity of discharged leachate from both sources, however, is generally significantly less than occurs after the entire landfill reaches field capacity. From that time on, the quantity of leachate generated and discharged from the landfill is believed to be approximately equal to the amount of additional infiltration entering the landfill surface.

During the past 15 to 20 years, most landfill design engineers viewed both the uncontrolled discharge of leachate through the unlined floor of the landfill and the controlled collection and disposal of leachate from a lined landfill principally as issues that center on environmental impacts and the use of pollution control technology. Until recently, not much consideration was given to the impact that this type of a system water loss had on the rate of microbial activity and on biodegradation of organics within the landfill itself. In fact, this latter impact probably was not noticed before most states began requiring the installation of impermeable landfill final cover systems because this type of system water loss was usually offset by the amount of precipitation that infiltrated through the surface.

The recirculation of collected leachate in a landfill bioreactor appears to offer certain advantages in promoting biodegradation. The recycle of leachate generated before field capacity is reached prevents a system water loss from occurring and returns moisture to the landfill, which can be immediately used by microorganisms, thereby increasing both the

---

refuse moisture content and the rate of biodegradation. Once field capacity is reached, continued recycle of leachate also appears to have a significant beneficial effect on promoting microbial activity, further promoting the rate of biodegradation. Preliminary data suggest the complete biodegradation of MSW organics in a landfill incorporating bioreactor technology might be achieved in about 8 to 10 years, compared with many older MSW landfills, where the biodegradation process is known to have taken many decades or even stopped completely due to a lack of refuse moisture.

Since the promulgation of Resource Conservation and Recovery Act (RCRA) Subtitle D criteria for MSW landfills in the early 1990s, the U.S. Environmental Protection Agency (EPA) has adopted a policy that requires incremental closure of landfills and immediate installation of a RCRA cap and final cover system on the closed portion of the landfill. In most cases, the RCRA cap incorporates a synthetic geomembrane that prevents any infiltration of precipitation or snowmelt into the refuse during the postclosure period.

This paper addresses the impact of those two actions on the development and successful implementation of bioreactor technology in future MSW landfills. It will be shown that total water requirements to achieve complete, or nearly complete, biodegradation of organics in landfills are substantially greater than previously estimated due to significant microbial water consumption and other system water losses that occur during the process of methanogenesis. Furthermore, it will be shown that all further microbial activity within the landfill ceases if the moisture content of the refuse drops below a certain level at any time during the biodegradation process. This paper addresses the impact that the timing of landfill closure events and the installation of a synthetic geomembrane cap in the final cover system at closure have on both the biological processes within the landfill and on bioreactor technology itself.

## Background

The average composition of U.S. MSW during the 1970s and 1980s is shown in Table 1. Approximately 80 to 85 percent of the MSW consisted of combustible organics. Biodegradable organics comprised primarily paper of all types and yard wastes. Biodegradable organics constituted about 70 percent of the refuse that went into landfills. A closer look at the biodegradable material (presented in Table 2) shows that about 68 percent was made up of decay-resistant cellulosic wastes and the rest consisted of rapidly decaying food wastes and vegetative matter. Landfilled MSW of this period generally had an initial moisture content of about 25 percent, a field capacity moisture content of between 45 and 50 percent, and a compacted placement density of about 1,000 lb/yd<sup>3</sup>.

Most older U.S. landfills were operated for some time before closure, and a life of 15 to 20 years was common. As shown in Tables 3 and 4, depending on climate, precipitation, and permeability of the soils used for daily and intermediate cover, the amount of net infiltration entering a landfill during operation varied from just a few to over 15 in./yr. The exception occurs in dry climates where evapotranspiration exceeds precipitation and landfilled MSW actually loses moisture with time. Because the amount of moisture needed to raise the MSW from 25 percent to field capacity theoretically should be about 1.5 in./ft of refuse thickness, the number of years it would take to reach field capacity at various rates of infiltration can be



calculated as shown in Table 4. It can be seen from this simplistic approach that it would theoretically take only 5 years for a 50-ft-high landfill in Florida to reach field capacity, compared with 15 years or more in a dryer, colder climate. These timeframes are valid assuming that no system water losses occurred within the landfill. If system water losses did occur due to the escape of leachate or for the reasons discussed later, the total time to reach field capacity would be greater than shown in Table 4. In fact, the vast majority of older MSW landfills probably did not reach field capacity prior to closure in 15 to 20 years, as shown in Figure 1. Following closure, the moisture content of the refuse would continue to increase but generally at a reduced rate due to the lower rate of infiltration through the final cover soil layer that was typically installed.

**Table 1. Average U.S. MSW Composition From 1975 to 1990**

| <b>Materials</b>                                 | <b>Percent of Total MSW</b> |
|--|-----------------------------|
| <b>Organics:</b>                                 |                             |
| <i>Biodegradable</i>                             | 69                          |
| Cellulosic                                       |                             |
| Paper  | 40%                         |
| Wood and lumber                                  | 5%                          |
| Noncellulosic                                    |                             |
| Leather, textiles                                | 2%                          |
| Food waste                                       | 7%                          |
| Yard waste                                       | 15%                         |
| <i>Nonbiodegradable</i>                          | 14                          |
| Plastics, rubber, asphalt,<br>synthetic fabrics  |                             |
| Total organics                                   | <hr/> 83                    |
| <b>Inorganics:</b>                               |                             |
| Glass, metals, ceramics,<br>concrete, soil, rock | 17                          |
| <b>Total MSW</b>                                 | <hr/> <hr/> 100             |

**Table 2. Analysis of Biodegradable Material Present in U.S. MSW From 1975 to 1990**

| Type                | Percent of Total | Rate of Decomposition |             |
|---------------------|------------------|-----------------------|-------------|
|                     |                  | Type                  | Percent     |
| Cellulosic          | 65               | Slow                  | Slow<br>68  |
| Noncellulosic:      |                  |                       |             |
| Leather, textiles   | 3                | Slow                  | Rapid<br>32 |
| Food and yard waste | 32               | Rapid                 |             |
| Total               | 100              |                       | 100         |

**Table 3. Addition of Moisture After Waste Placement To Promote Biodegradation**

| Site Conditions                         | Moisture (in./yr) |
|---|-------------------|
| <b>A Typical Site in Mid-America</b>    |                   |
| — Moderate climate                      |                   |
| — Annual precipitation                  | 40                |
| — Moderate evapotranspiration           |                   |
| — Soil permeability of $10^{-5}$ cm/sec |                   |
| — Ground-water recharge                 | $8\frac{1}{4}$    |
| <b>Infiltration During Operations</b>   |                   |
| — Working face                          | 10 - 15           |
| — Daily and intermediate cover          | 5                 |
| <b>Infiltration After Closure</b>       |                   |
| — 24 in. of cover soil                  | 3 - 4             |
| — Soil bentonite or clay cap            | 1 - 2             |
| — Geomembrane cap                       | 0                 |

**Table 4. Time Required To Reach Field Capacity Prior to Landfill Closure in Older U.S. Landfills<sup>a,b</sup>**

| Average Height of Landfill (ft) | Total Infiltration Needed To Reach Field Capacity (in.) | Time To Reach Field Capacity (yr) for Various Infiltration Rates |           |          |
|---------------------------------|---|--|-----------|----------|
|                                 |   | 15 In./Yr  | 10 In./Yr | 5 In./Yr |
| 10                              | 15  | 1  | 1.5       | 3        |
| 50                              | 75  | 5  | 7.5       | 15       |
| 100                             | 150   | 10   | 15        | 30       |
| 150                             | 225   | 15   | 23        | 45       |

<sup>a</sup>Assumes no net loss of water within or from the landfill.

<sup>b</sup>Shaded areas represent landfill situations where field capacity is not reached prior to closure within 15 to 20 years.

In most landfills, field capacity would eventually be reached a number of years after closure, with the length of time usually directly attributed to the 'tightness' of the final cover. It was generally assumed that if a synthetic geomembrane cap were installed at closure, as has been the practice in the United States for about the past 5 years, infiltration would be reduced to zero and field capacity would never be reached unless it had already been achieved prior to closure. As shown in Figure 1, it was also generally assumed that the moisture content of the refuse would remain constant after a geomembrane cap was installed, and if the moisture level were high enough, the biodegradation process would continue until nearly 100-percent decomposition of the organics was achieved.

Finally, in older landfills that were typically operated for 15 to 20 years before closure, it was generally assumed that about half of the biodegradation process occurred before closure and the rest afterward (see Figure 2). The data analyzed in Tables 5 and 6 tend to substantiate this assumption because most of the early biodegradation can be attributed to the rapid breakdown of noncellulosic materials that constituted nearly one-third of the total biodegradable material. As expected, the majority of postclosure biodegradation could be attributed to the slow rate of decay of cellulosic wastes.

#### **Landfill Bioreactor Technology and the Resource Conservation Recovery Act**

Bioreactor technology is a method of obtaining a more controlled, rapid rate of anaerobic biodegradation in modern lined landfills by recirculating collected leachate during landfill operation and also possibly for some time after closure. The recycle of leachate generated during the active life of the landfill back into the refuse is intended to shorten the time

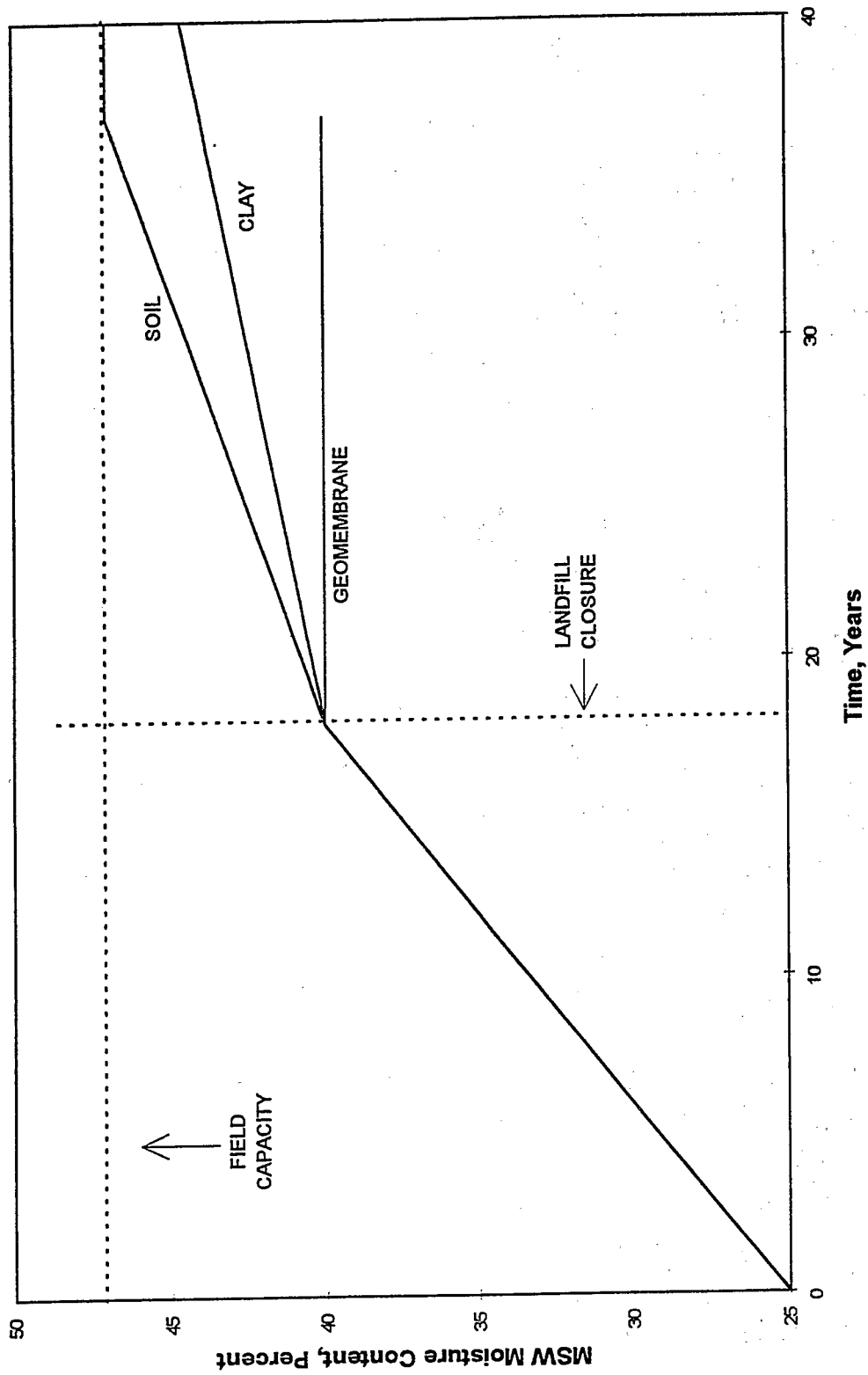

Figure 1. Estimated time required to reach and maintain field capacity in older U.S. landfills.

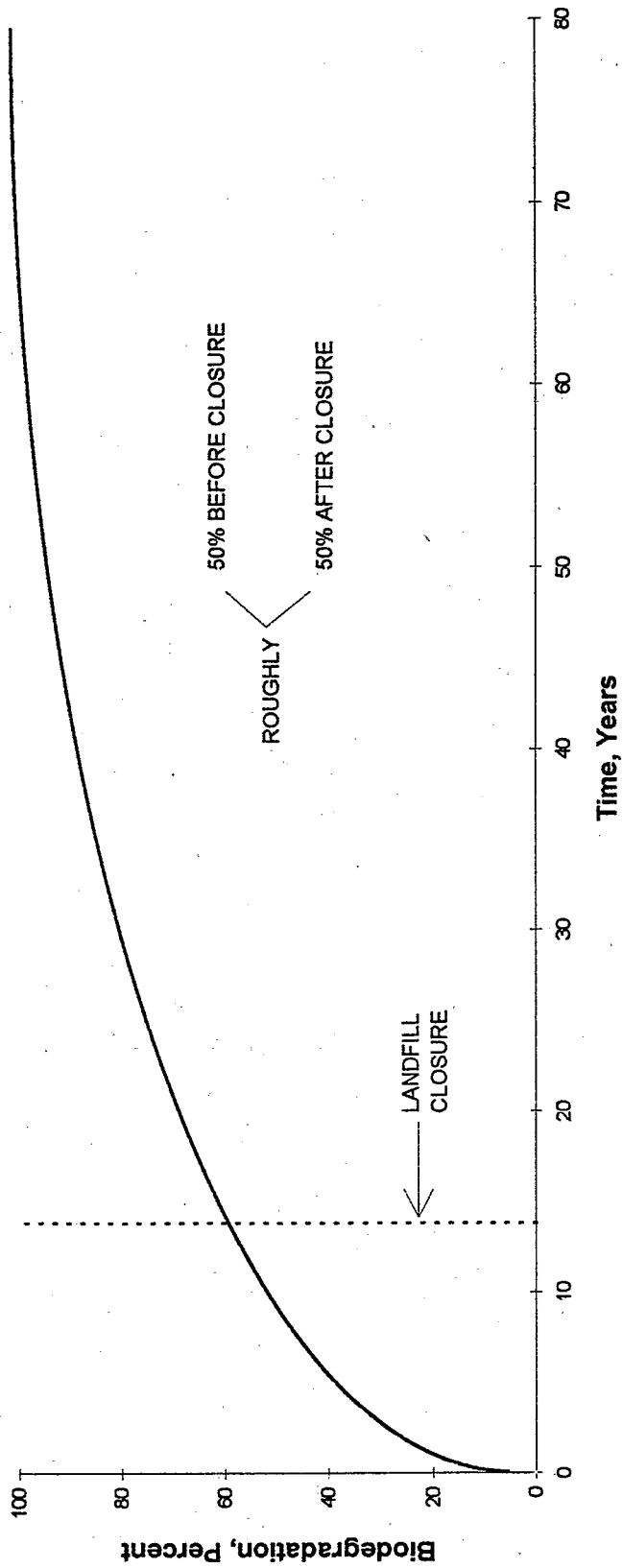

Figure 2. Estimated time required to achieve complete biodegradation in older U.S. landfills.

**Table 5. Biodegradation Before Closure in Older U.S. Landfills**

|                                   | Percent of Total Biodegradable Material | X | Estimated Degree of Degradation at Closure | = | Relative Amount of Biodegradation |
|-----------------------------------|---|---|--|---|-----------------------------------|
| Noncellulosic (Rapid Degradation) | 32                                      | X | 80%  | = | 26%                               |
| Cellulosic (Slow Degradation)     | 68                                      | X | 35%  | = | 24%                               |
| <b>Total</b>                      | <b>100</b>                              |   |  |   | <b>50%</b>                        |

**Table 6. Biodegradation After Closure in Older U.S. Landfills**

|                                   | Percent of Total Biodegradable Material | X | Estimated Degree of Degradation Remaining | = | Relative Amount of Biodegradation |
|-----------------------------------|---|---|---|---|-----------------------------------|
| Noncellulosic (Rapid Degradation) | 32                                      | X | 20%                                       | = | 6%                                |
| Cellulosic (Slow Degradation)     | 68                                      | X | 65%                                       | = | 44%                               |
| <b>Total</b>                      | <b>100</b>                              |   |   |   | <b>50%</b>                        |

required for the MSW to initially reach field capacity by replenishing the landfill with moisture that would otherwise be lost to the biological system. Ideally, field capacity should be achieved before closure (see Figure 3) so that the bioreactor process can be sustained at field capacity for about 8 to 10 years in order to result in the nearly complete degradation of the MSW (see Figure 4). This concept applies well in the context of the way our MSW landfills were operated before passage of RCRA Subtitle D because our landfills were normally operated for longer periods before closure. Since RCRA, three important factors have changed:

- Composition of the biodegradable fraction of MSW has been and will continue to be affected by recycling programs designed to divert most of the rapidly decaying organics that previously accounted for a significant amount of biodegradation prior to closure.

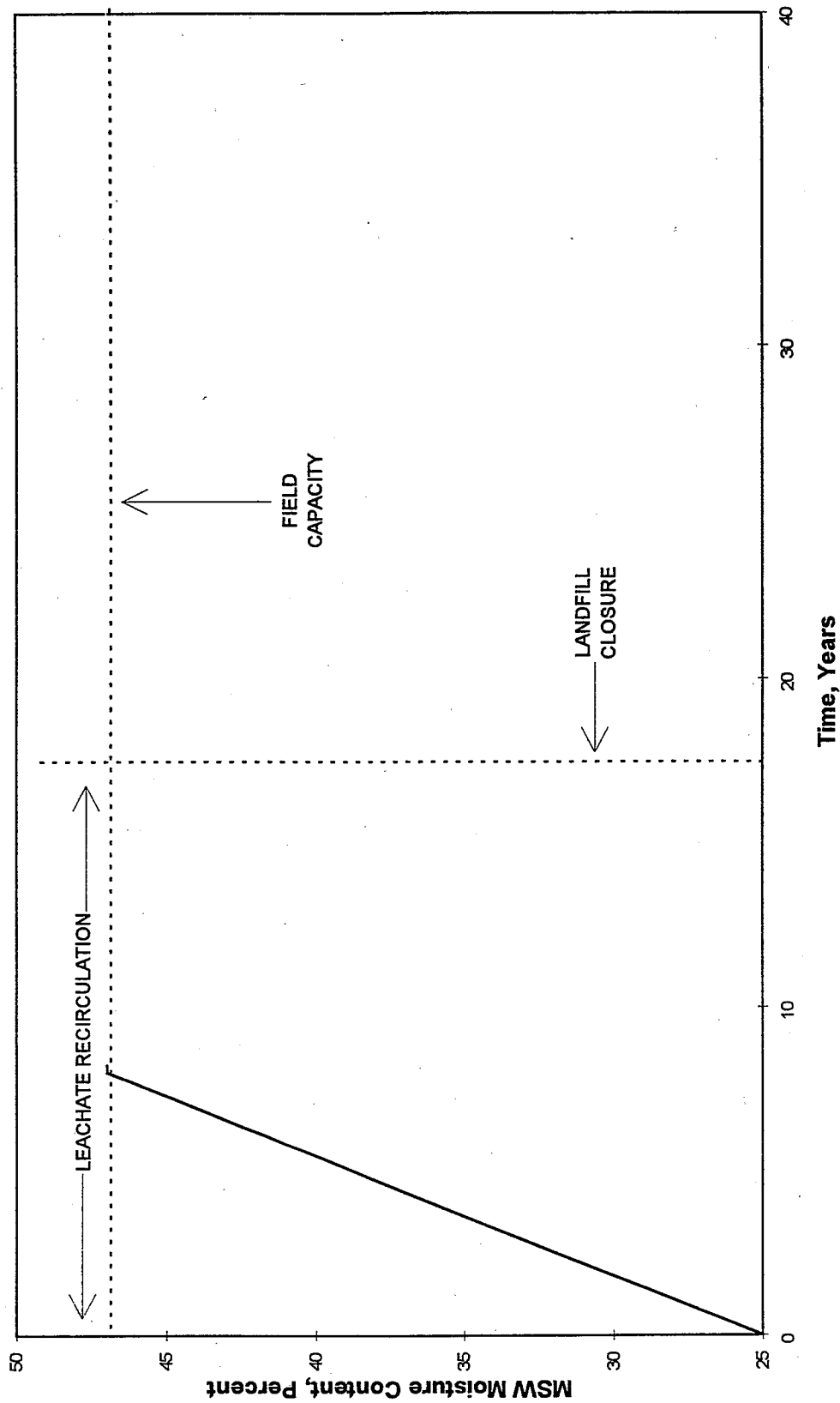

Figure 3. Estimated time required to reach and maintain field capacity using bioreactor technology.

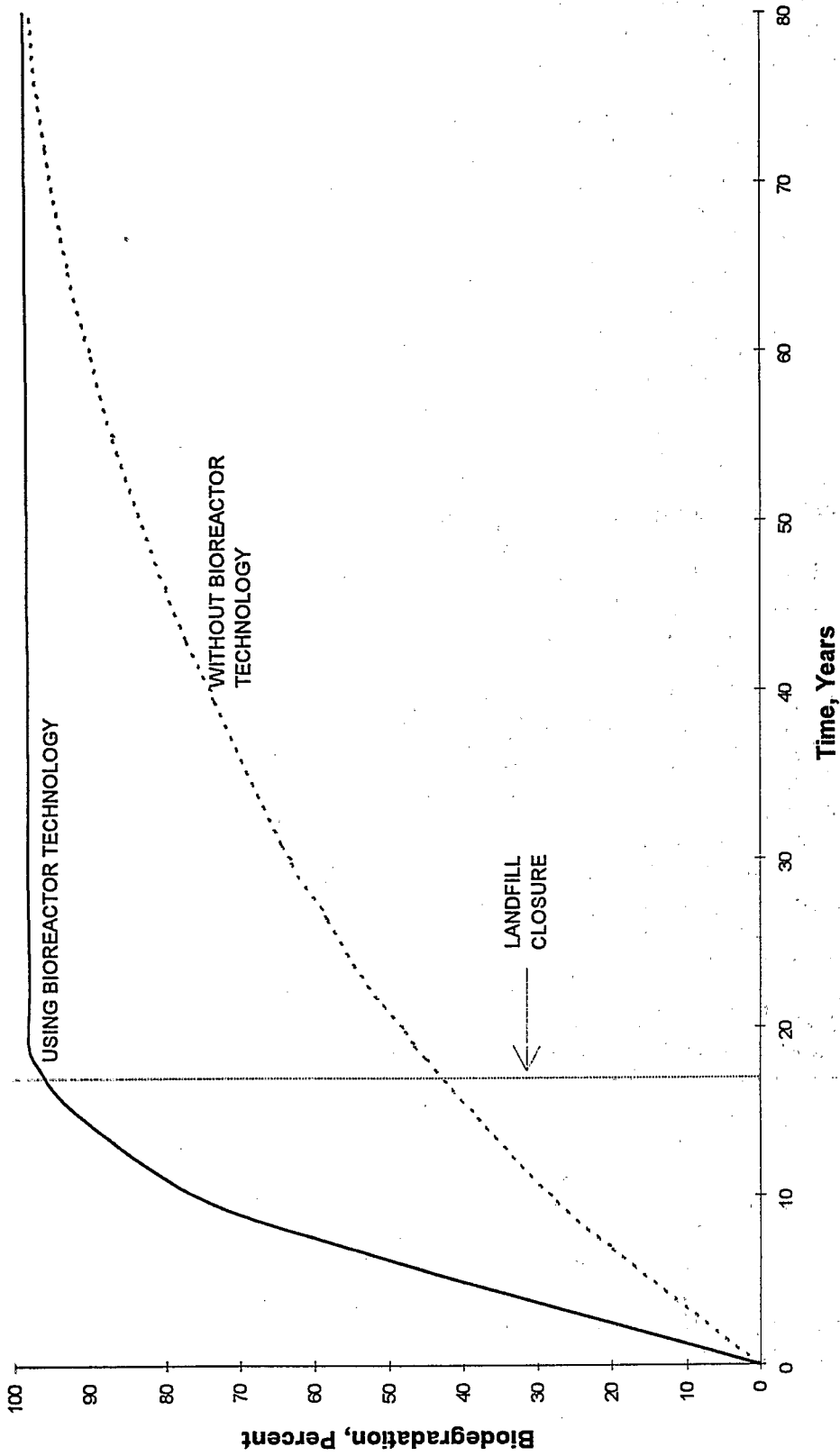

Figure 4. Estimated time required to achieve complete biodegradation using bioreactor technology.



- The financial assurance requirements of RCRA are now forcing landfill owners to plan and implement progressive closures of the facility in increments over its active life, rather than postpone closure as a one-time event after all operations cease. This action will decrease the average amount of time between waste placement and closure by a significant amount.
- EPA now requires that all new landfills that contain a synthetic geomembrane in the composite floor liner also incorporate a geomembrane in the landfill cap, which must be installed at closure. This requirement effectively limits the amount of water that is available to the biodegradation process only to the amount of moisture that is added to the MSW by infiltration prior to closure, even if leachate recycle is continued during the postclosure period.

The issues raised by these changes as they affect the closure and postclosure aspects of MSW landfill bioreactor technology are discussed in the following sections.

### **Impact of Recycling on Waste Composition**

Under RCRA, most jurisdictions in the United States are striving to divert between 25 and 40 percent of their pre-RCRA waste stream by the year 2000 through various waste reduction, reuse, and recycling programs. A typical program to achieve a goal of 40-percent waste-stream reduction is depicted in Table 7. In most areas, yard wastes are targeted for complete removal. If the pre-RCRA waste composition (see Table 1) is adjusted to reflect the changes targeted by a 40-percent waste diversion goal, the average future MSW waste composition and properties will probably be similar to those depicted in Tables 8 and 9. Surprisingly, the total organics content of future MSW is not expected to change significantly, nor is the total quantity of biodegradable material, which will remain about 65 percent. A significant change will occur, however, in the characteristics of the biodegradable material (see Table 10) as a result of the yardwaste diversion programs. The amount of decay-resistant cellulosic material in MSW is expected to increase from less than 70 percent to more than 80 percent of the total by the year 2000. All other factors being equal, less biodegradation will be achieved prior to closure than before, with or without the use of bioreactor technology. Because a greater percentage of future biodegradable organics in the MSW will comprise slowly decaying cellulosic material, the application of bioreactor technology may be even more relevant in the future to accomplish organics stabilization in a reasonably short time.

### **Impact of the Resource Conservation and Recovery Act on Landfill Operational Life**

Current EPA policy dictates a significant change in the manner in which current and future MSW landfills are operated. As shown in Figure 5, the "rush to closure" philosophy is resulting in a significant decrease in the amount of time between waste placement and closure of individual sections or cells of the landfill. Most MSW landfills today are being designed and permitted for phased closure increments generally no farther apart than 5 to 10 years, a full 10-year decrease from the manner in which most of the older landfills were

**Table 7. Impact on Future MSW Composition of Achieving a 40-Percent Recycling Goal**

|   |
|---|
| <p>Target Programs:</p> <ul style="list-style-type: none"> <li>— Divert up to 30 percent of all paper and corrugated</li> <li>— Divert at least 50 percent of all wood and lumber</li> <li>— Divert 100 percent of all yard waste and leaves</li> <li>— Divert all recyclable plastics</li> <li>— Divert as much glass and recyclable metals as possible</li> </ul> |
|---|

**Table 8. Estimated Postrecycle MSW Composition for 40-Percent MSW Diversion**

| Materials                                     | Percent of Total MSW |
|---|----------------------|
| <b>Organics:</b>                              |                      |
| <i>Biodegradable</i>                          | 65                   |
| Cellulosic                                    |                      |
| Paper   | 46%                  |
| Wood and lumber                               | 4%                   |
| Noncellulosic                                 |                      |
| Leather, textiles                             | 3%                   |
| Food waste                                    | 12%                  |
| Yard waste                                    | -----                |
| <i>Nonbiodegradable</i>                       | 16                   |
| Plastics, rubber, asphalt, synthetic fabrics  | -----                |
| Total organics                                | 81                   |
| <b>Inorganics:</b>                            | 19                   |
| Glass, metals, ceramics, concrete, soil, rock | -----                |
| <b>Total MSW</b>                              | <b>100</b>           |

**Table 9. Postrecycle MSW Properties**

|  |   |
|--|---|
| Moisture content at placement                        | Approximately 20 to 25 percent                      |
| Density at placement                                 | 1,200 lb/yd <sup>3</sup>                            |
| Moisture content at field capacity                   | Approximately 45 to 50 percent                      |
| Additional moisture required to reach field capacity | 1.75 in. H <sub>2</sub> O per ft of waste thickness |

**Table 10. Estimate of Postrecycle Biodegradable Material Present in U.S. MSW After the Year 2000**

| Type              | Percent of Total | Rate of Decomposition |             |
|-------------------|------------------|-----------------------|-------------|
|                   |                  | Type                  | Percent     |
| Cellulosic        | 77               | Slow                  | Slow<br>82  |
| Noncellulosic:    |                  |                       |             |
| Leather, textiles | 5                | Slow                  | Rapid<br>18 |
| Food waste        | 18               | Rapid                 |             |
| <b>Total</b>      | <b>100</b>       |                       | <b>100</b>  |

operated. When this factor is combined with the fact that future MSW will contain a higher percentage of decay-resistant cellulose, it implies that:

- It will be much less likely that the moisture content of the MSW in the landfill will reach field capacity before closure, with or without bioreactor technology (see Figure 6), unless leachate is provided from another source such as an older landfill.
- Due to the presence of less rapidly decomposing organics in postrecycle MSW, the degree of biodegradation achieved prior to closure will be much less than experienced in older landfills (see Figure 7). Without leachate recycle, the total amount of biodegradation achieved prior to closure in 5 to 10 years might only be approximately 20 percent. Even with leachate recycle, it does not seem likely that much more than 30-percent biodegradation can be accomplished in that short timeframe, if field capacity is not attained.

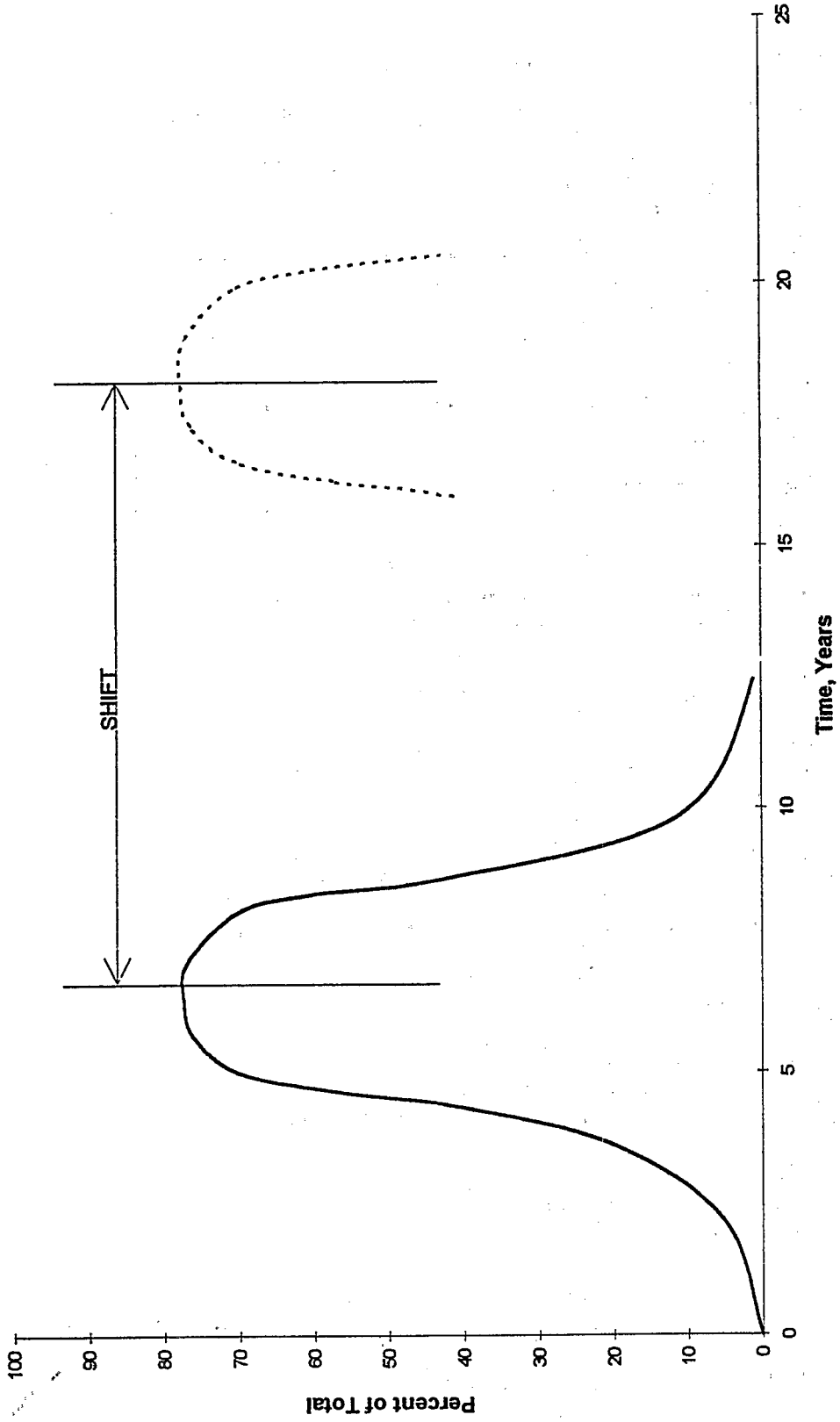

Figure 5. Operational life before closure of individual phases or cells of RCRA landfills.

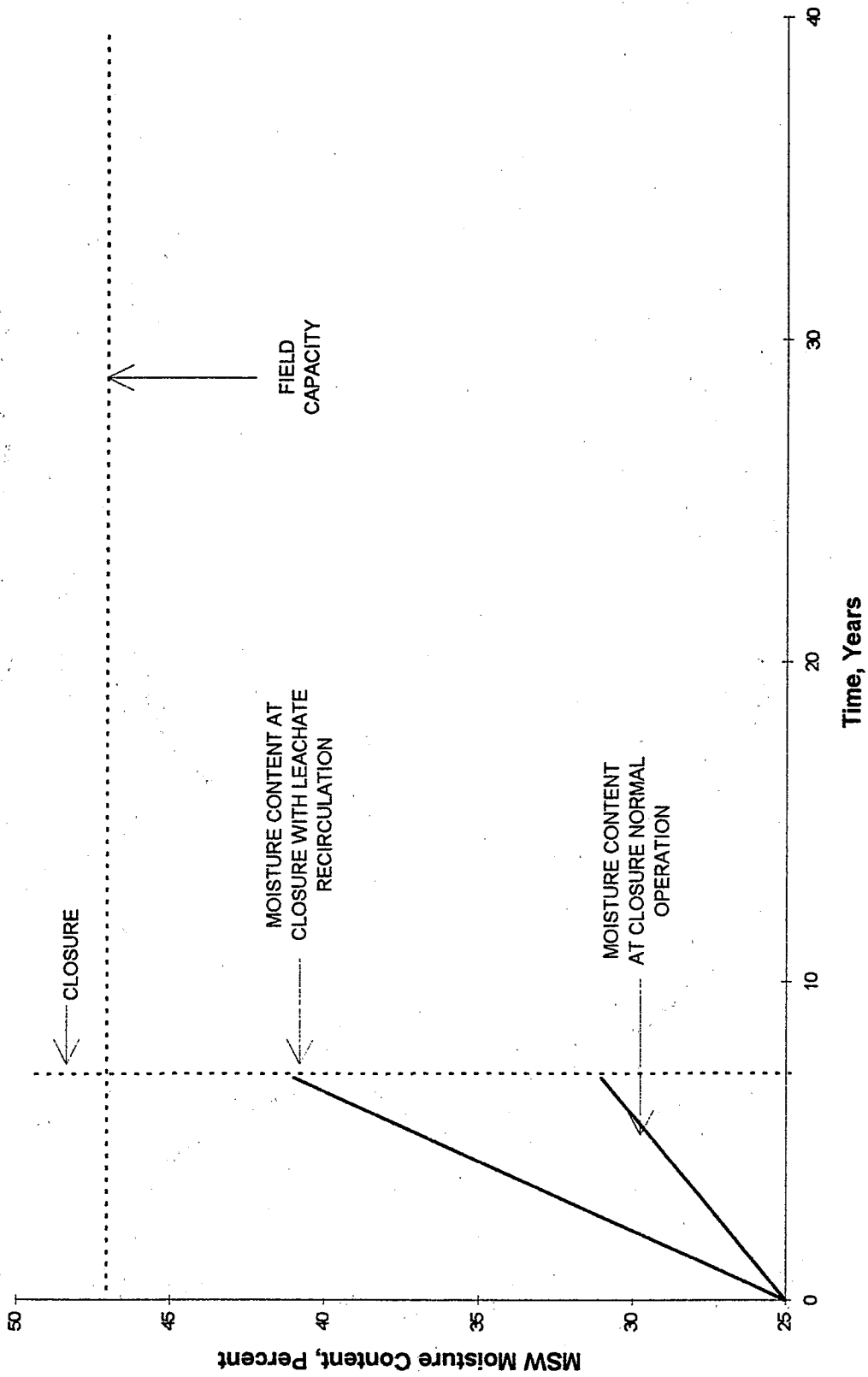

Figure 6. Estimated time required to reach field capacity in RCRA landfills.

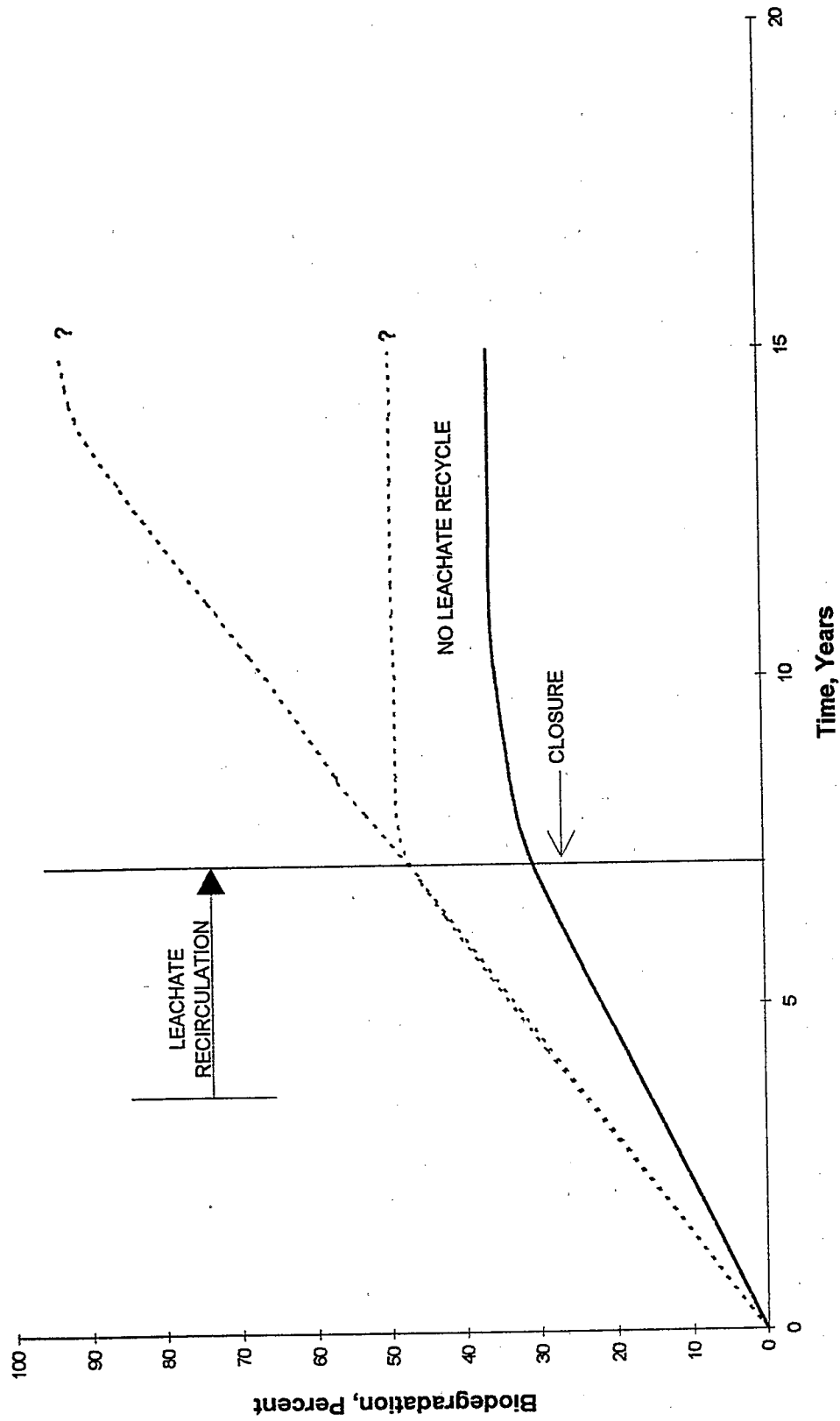

Figure 7. Impact of installing a geomembrane cap at closure in RCRA landfills without leachate recirculation after closure.

As depicted in Figure 7, it previously has not been entirely clear what will happen to the rate of microbial activity after closure occurs in 5 to 10 years and a geomembrane cap is installed that prevents further infiltration. Current thinking suggests that if the moisture content of the refuse was not increased to the point of stimulating a significant rate of microbial activity before closure, then the landfill will become dormant shortly after closure. One school of thought suggests that if enough microbial activity has been generated, it may be possible that even without leachate recycle after closure, biodegradation will continue to occur at some decreasing rate for many years until finally becoming nearly 100 percent complete. Another school of thought suggests that if leachate recycle is continued after closure, the goals of bioreactor technology can still be achieved. Unfortunately, data recovered from several landfills that were capped with a geomembrane at closure are proving both schools of thought to be wrong.

### **Impact of Installing a Resource Conservation and Recovery Act Cap at Closure**

#### *Sources of Landfill System Water Gain*

In 1994, EPA clarified its policy on MSW landfill closure to state that "all RCRA landfills that incorporate a synthetic geomembrane in the floor liner system shall also incorporate a geomembrane in the final cover system." Because EPA will only allow leachate recycle in lined landfills and the vast majority of all future lined MSW landfills will contain a RCRA composite floor liner, it is a given that most future MSW landfills will have a geomembrane cap and final cover system installed at closure.

The installation of an impermeable geomembrane cap will have a profound effect on the water balance in future landfills because it will limit the period during which a net moisture gain can occur in the refuse only to the time that active landfilling operations are taking place. During this average period of 5 to 10 years, moisture can be derived from only three sources:

- Initial MSW moisture content
- Infiltration
- Leachate recycle

Leachate recirculation represents a source of new water added to the landfill bioreactor system only to the extent that prior to the time the entire landfill reaches field capacity, the recycled leachate consists of infiltration water that was not initially absorbed by the refuse as it passed through the waste and would otherwise be lost to the system if allowed to be discharged from the landfill. Once field capacity is achieved, leachate recirculation no longer can be considered a source of additional moisture. The process then only serves to recycle excess infiltration that has entered the landfill but could not be retained in the waste because the absorptive capacity and holding (in-void) capacity of the refuse have already been attained. Thus, by definition, once field capacity is reached, infiltration can be the only source of new moisture entering the landfill. The amount of additional infiltration that enters the landfill between the time field capacity is reached and closure occurs has generally been viewed as excess water in the landfill system because it cannot be absorbed and would have no effect on further raising the moisture content of the refuse when recycled. This moisture

can help, however, to counteract some of the effects of the other system water losses that will be described.

Once the geomembrane cap is in place, no further infiltration can occur (unless there is a breach in the cap, or it is removed) and there can be no source of additional moisture entering the landfill system. The maximum amount of moisture in the landfill at closure and during postclosure will be equal to the sum of that absorbed by the refuse at its field capacity (assuming that field capacity is reached prior to closure, which may be unlikely) and the excess infiltration that occurred prior to closure only if it is continuously returned to the landfill via leachate recirculation.

If field capacity is not reached throughout the entire landfill cell prior to its closure in 5 to 10 years, a condition that may reflect the majority of situations in future landfills, it has generally been assumed that no further change in moisture content will occur in the refuse during the postclosure period (see Figures 8 and 9). Clearly, the postclosure moisture content of refuse where leachate recycle has not been performed will be lower than where recycling has been conducted prior to closure. Once closure occurs, however, any recirculated leachate probably will be quickly absorbed by the refuse within the landfill and leachate flow will stop, precluding any further recycle efforts unless leachate is then provided from another source.

#### *Sources of Landfill System Water Loss*

The general assumption that the moisture content of the MSW in the landfill remains constant and does not decrease in time after installation of a geomembrane cap is proving to be quite wrong. In fact, from the time during the period of active landfill operations when the average moisture content of the MSW rises above 34 percent and the biodegradation of cellulosic materials begins to occur, the landfill will begin to experience significant system water losses that can be attributed to the following sources:

- Biological water demand.
- Escape of water vapor contained in saturated biogas that is vented or flared.
- Leachate that is discharged from the landfill in the leachate collection system and not recirculated.

All three of these sources of water loss occur during the active life of the landfill at the same time that the landfill experiences water gain from infiltration and leachate recirculation. In fact, throughout the active life of the landfill, the quantity of system water gain appears to be significantly greater than the quantity of system water loss so that, normally, an observed increase in refuse moisture content occurs with time. The rate of system water loss, however, which starts out very slow at first, increases dramatically with time as the process of methanogenesis, or breakdown of cellulose into carbon dioxide and methane gases, accelerates. This phenomenon may be the principal reason why the observed time for



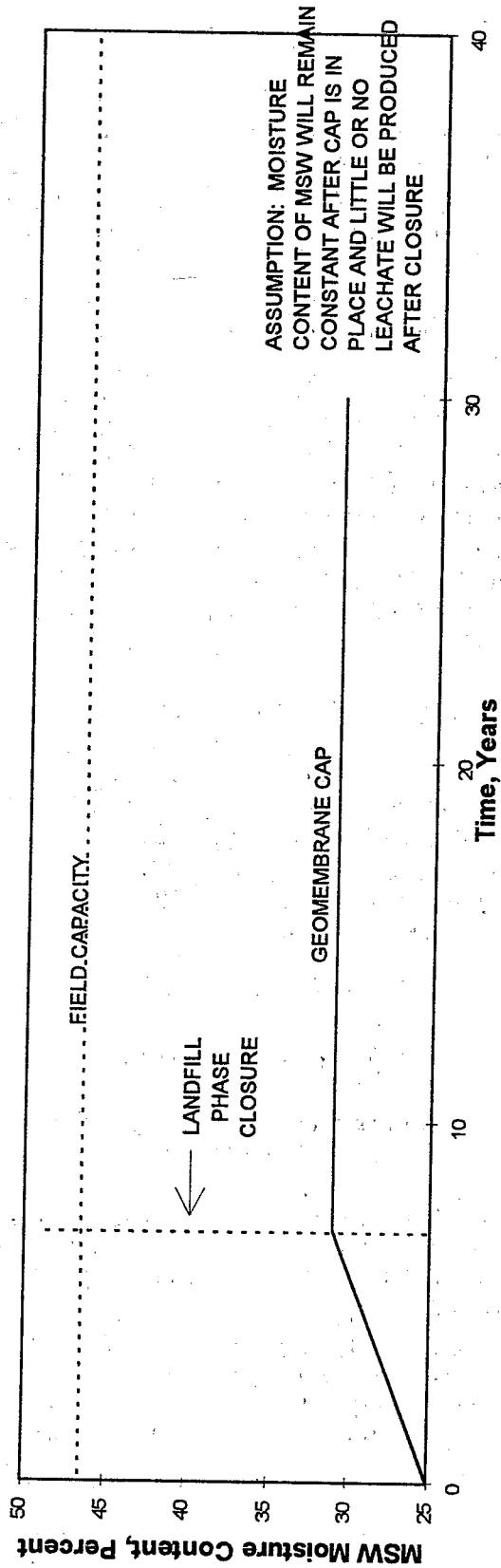

Figure 8. Estimated time required to reach field capacity in RCRA landfills prior to closure without leachate recirculation.

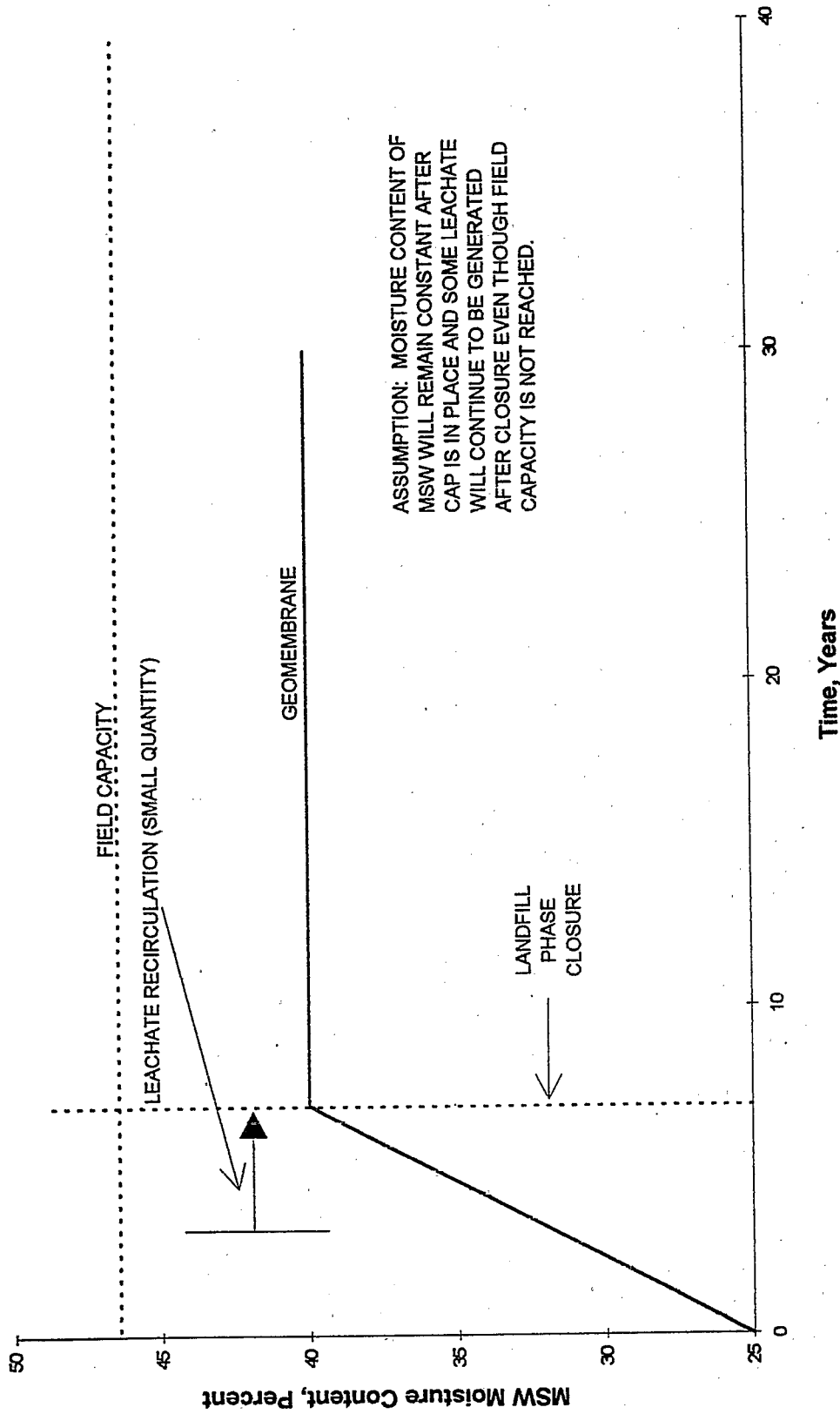

Figure 9. Estimated time required to reach field capacity in RCRA landfills prior to closure with landfill bioreactor technology.

landfills to reach field capacity generally takes longer than the time calculated based only on net infiltration rates. It may also be one of the reasons that early versions of the EPA Hydrologic Evaluation of Landfill Performance (HELP) model tended to overestimate the rate of leachate generation.

Because most future MSW landfills will contain a larger percentage of cellulosic materials than in the past, and because closure events will generally occur within 5 to 10 years after the start of waste placement, the total degree of biodegradation occurring before closure may be only approximately 20 to 30 percent. As a result, the total amount of system water losses that are likely to occur in the landfill prior to closure from biological water demand and escaping biogas should be small compared with the total potential amount of water losses that would occur after closure if the conditions necessary to sustain the microbial activity can be maintained. Following closure of new RCRA MSW landfills, the principle source of system water gain, infiltration, will be eliminated, leaving a substantial water balance deficit to accomplish complete biodegradation.

As depicted in Table 11, methanogenesis is a complex biological process consisting of four stages or phases where, in an anaerobic environment and in the presence of ample moisture, microorganisms break down cellulose into carbon dioxide and water. The summation of all the organic chemical reactions is also presented in Table 11. The organic equation reveals two important facts:

- To sustain the complete process of methanogenesis, the microorganisms must have access to three molecules of water for each molecule of cellulose to be converted. Based on the molecular weights of the two sets of molecules, the minimum water content necessary to sustain methanogenesis is 34 percent.
- For each molecule of cellulose converted to carbon dioxide and methane, there is a net water consumption loss (biological water demand) of 33 percent. The process starts with three molecules of liquid water and ends with two molecules of water vapor.

Because future MSW will consist of about 65 percent biodegradable material, over 80 percent of which will be cellulosic, the biological water demand of the microorganisms will lower the moisture content of the entire landfill by 22 to 25 percent. This decrease will take place as long as the moisture content of the MSW in the landfill does not drop below about 34 percent. If this does happen, the biodegradation process will not be carried much beyond the 30 percent completion that occurred prior to closure and will progressively come to a halt due to water starvation.

A second major source of water loss from the landfill system can be attributed to moisture, in the form of water vapor, that is carried out of the landfill with biogas. A portion of the water vapor produced along with carbon dioxide and methane during methanogenesis remains trapped within the saturated biogas. As the biogas seeps into the atmosphere through the daily and intermediate soil cover during operation, and as it is deliberately vented to the atmosphere or burned in vent flares during the postclosure period, the saturated biogas will

**Table 11. Methanogenesis**

|   |   |                 |     |                                      |                     |
|---|---|-----------------|-----|--------------------------------------|---------------------|
| <b>Definition of Methanogenesis</b>   |   |                 |     |                                      |                     |
| A complex series of organic chemical reactions used by microorganisms in the presence of water, and in an anaerobic environment, to biodegrade cellulose. |   |                 |     |                                      |                     |
| <b>Process of Biodegradation</b>  |   |                 |     |                                      |                     |
| Stage 1 - Cellulose breakdown to ethanol and acetate  |   |                 |     |                                      |                     |
| Stage 2 - Further conversion of ethanol to acetate  |   |                 |     |                                      |                     |
| Stage 3 - Methane formation by CO <sub>2</sub> reduction  |   |                 |     |                                      |                     |
| Stage 4 - Final acetate reduction   |   |                 |     |                                      |                     |
| <b>Summation of All Chemical Reactions</b>  |   |                 |     |                                      |                     |
| Cellulose   |   | Liquid<br>Water |     | Saturated Biogas<br>(w/ water vapor) |                     |
| $C_6H_{10}O_5$  | + | $3H_2O$         | --> | $3CO_2$                              | + $3CH_4$ + $2H_2O$ |

carry a significant amount of moisture with it as it leaves the landfill system. If the biogas is used for onsite electric power generation, a large part of this potential source of water loss can be averted by recirculating water recovered from condensate knockout equipment. If, however, the biogas is used or vented without condensate removal, and only a minor amount of condensate is recovered in header pipe condensate traps, then an additional moisture content decrease of at least 20 to 30 percent can occur if the methanogenesis process is carried to completion.

Finally, any controlled leachate discharge from the landfill during the postclosure period will also contribute to a net landfill system water loss unless it is recycled back into the landfill.

System water losses from both biological water demand and the release of saturated biogas can easily account for a total refuse moisture content decrease of between 35 to 45 percent during postclosure. If the landfill reached field capacity of 45 to 50 percent prior to closure, the subsequent system water losses could bring the moisture content down to the 24 to 32 percent range and below the minimum moisture content needed to sustain biodegradation. Clearly, if the landfill did not reach field capacity prior to closure and had a refuse moisture content of somewhere between 35 and 40 percent, the biodegradation process would rapidly deplete it of enough moisture to sustain the biodegradation process. The case history presented in the next section of this paper shows that complete cessation of all microbial activity in the landfill can occur within 3 to 5 years after placement of a geomembrane cap at closure. Biodegradation may not exceed 50 percent complete under even the best of

circumstances where the moisture content of the refuse had reached field capacity prior to closure, as illustrated in Figures 10 through 12.

**Documentation: A Case History**

The Regional Municipality of Ottawa-Carleton, in Ottawa, Canada, has operated the Trail Road Landfill since 1980. This landfill serves a population of about 780,000 in the nation's capital. The MSW waste composition and characteristics of the biodegradable fraction of the waste stream during the 1980s (see Tables 12 and 13) were quite similar to U.S. MSW of the same period. The initial moisture content, placement density, and field moisture content were also the same.

**Table 12. MSW Composition in Ottawa, Canada, During the 1980s**

| Materials                                     | Percent of Total MSW |
|---|----------------------|
| <b>Organics:</b>                              |                      |
| <i>Biodegradable</i>                          | 66                   |
| Cellulosic                                    |                      |
| Paper   | 35%                  |
| Wood and lumber                               | 6%                   |
| Noncellulosic                                 |                      |
| Leather, textiles                             | 4%                   |
| Food waste                                    | 12%                  |
| Yard waste, leaves                            | 9%                   |
| <i>Nonbiodegradable</i>                       | 12                   |
| Plastics, rubber, asphalt, synthetic fabrics  | -----                |
| Total organics                                | 78                   |
| <b>Inorganics:</b>                            |                      |
| Glass, metals, ceramics, concrete, soil, rock | 22                   |
| -----   | -----                |
| <b>Total MSW</b>                              | 100                  |

A plan view of the landfill, Figure 13, shows the three stages of the entire landfill as constructed to date. Stage 1 of the landfill was operated between May 1980 and July 1986. It does not contain a floor liner system and is situated over a glacial outwash deposit consisting primarily of gravelly, silty, fine sands. The surface of the ground-water table is located about 10 to 15 ft below the landfill floor and has never risen up into the landfill.

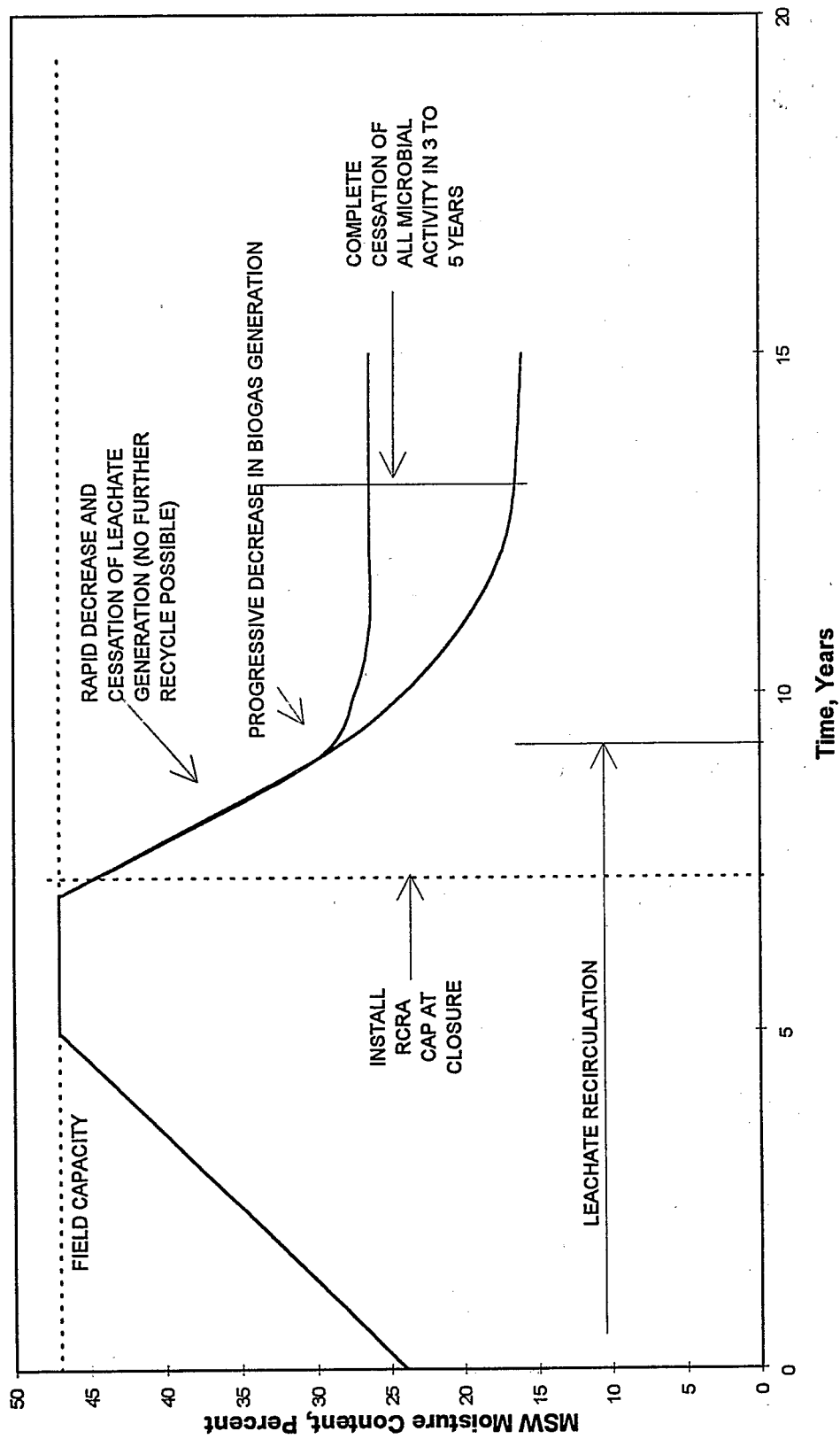

Figure 10. Impact of installing a geomembrane cap at closure in RCRA landfills where field capacity has already been reached.

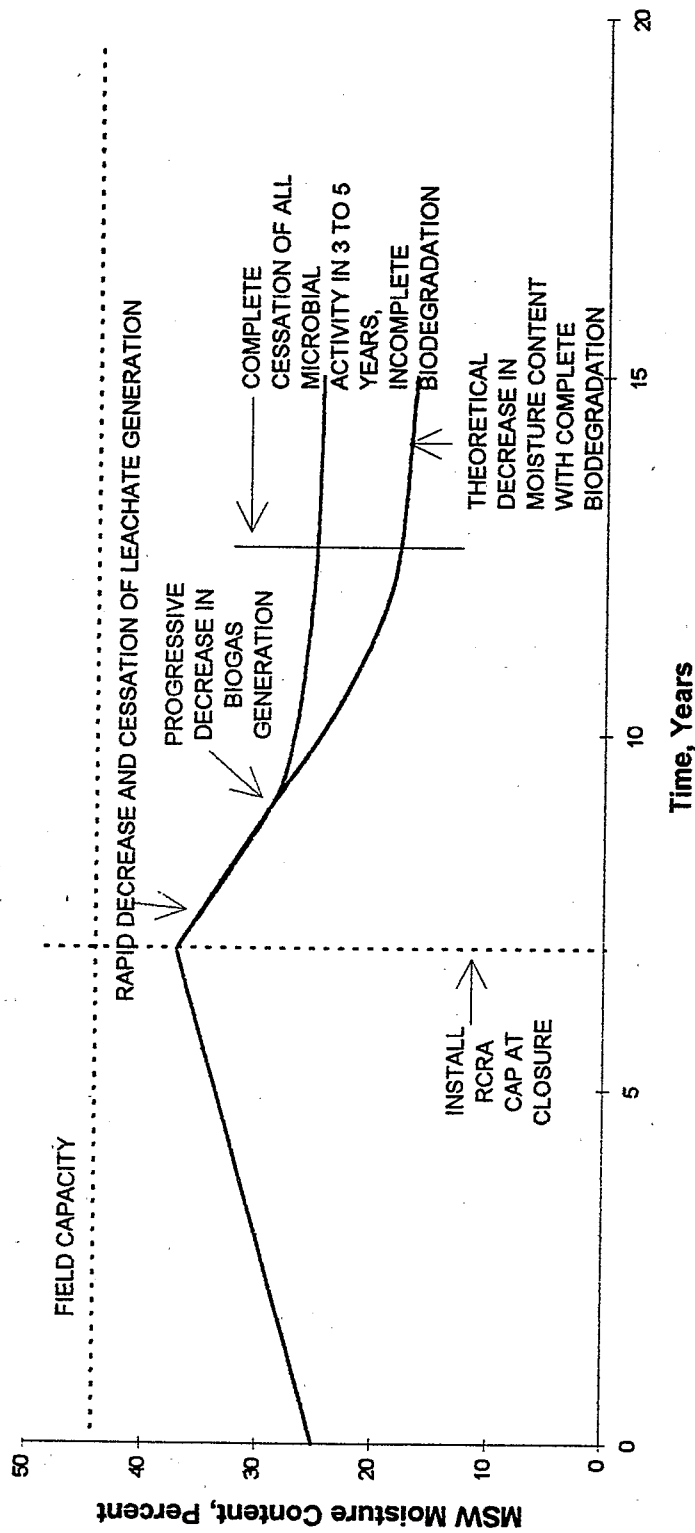

Figure 11. Impact of installing geomembrane cap in RCRA landfills at closure.

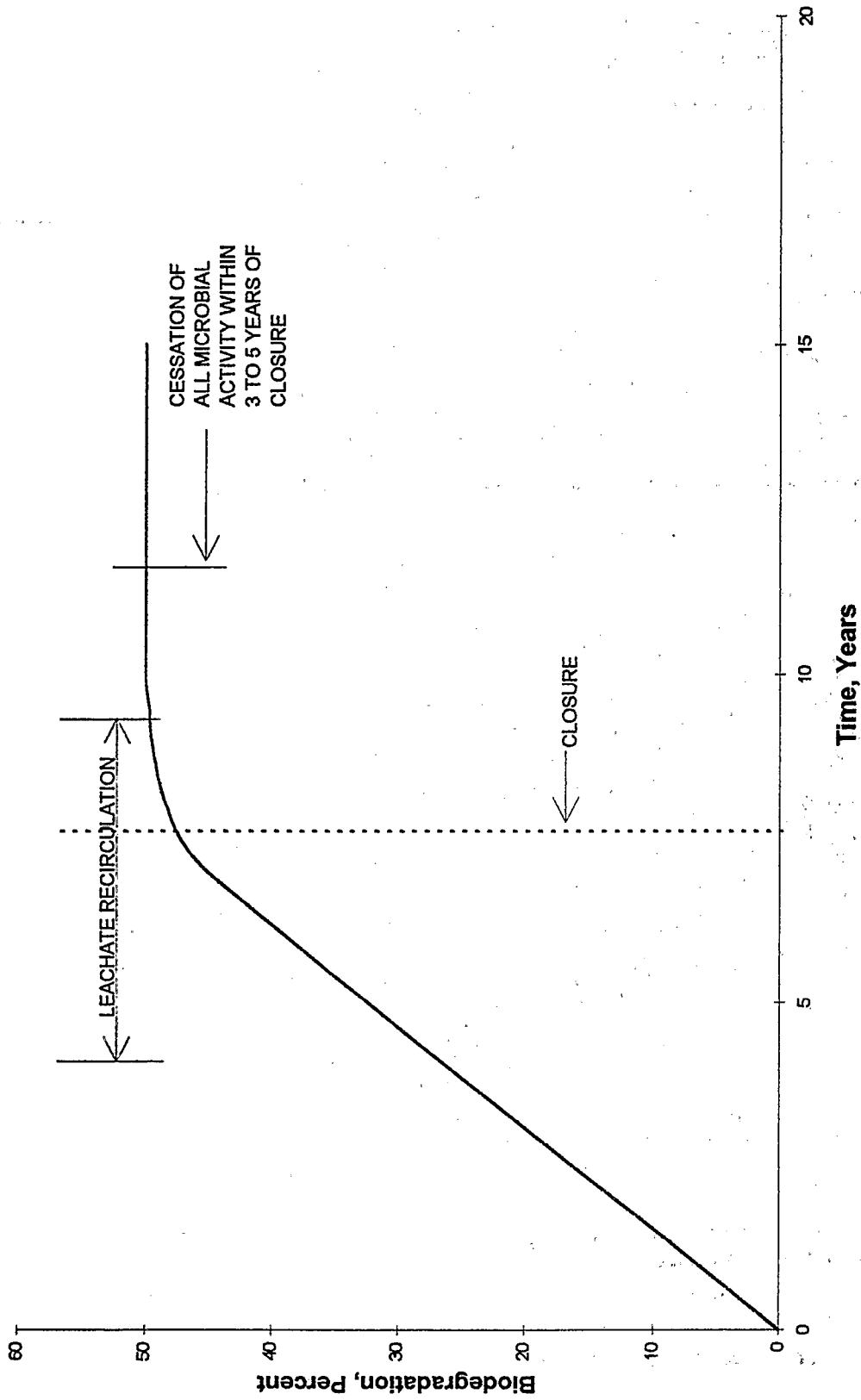
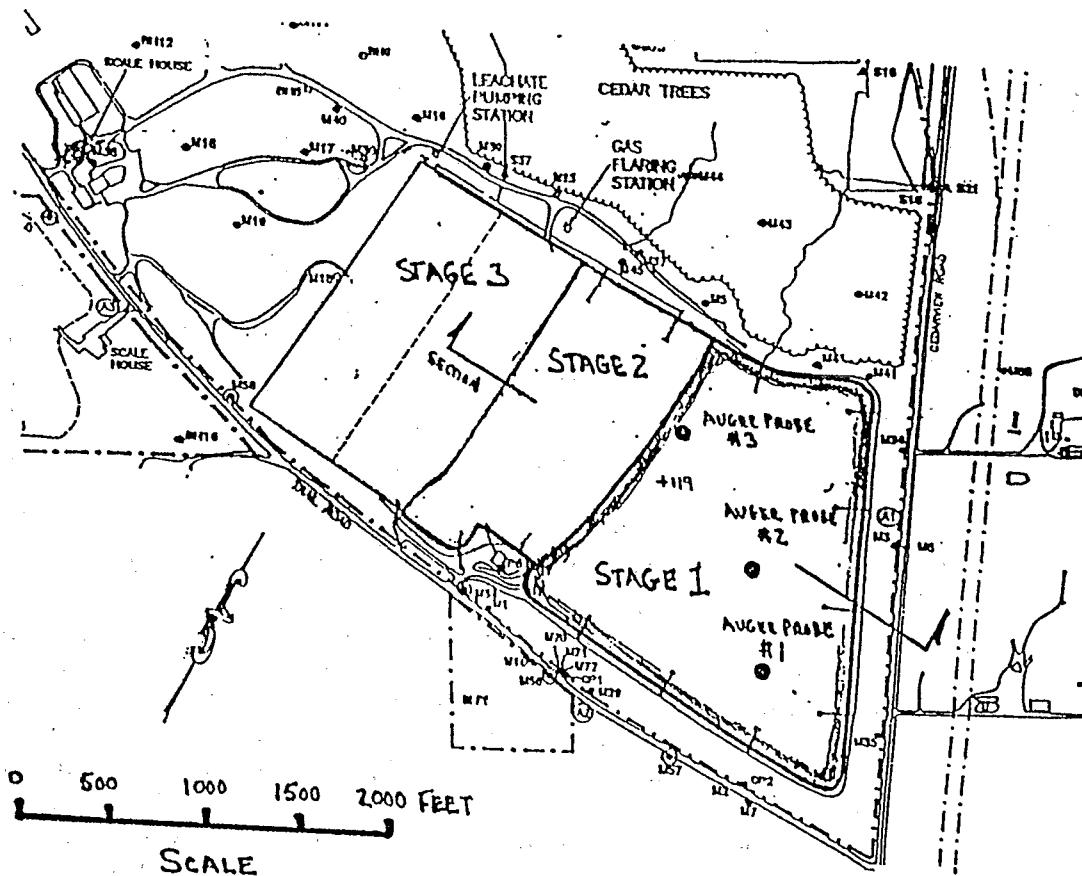

Figure 12. RCRA landfills: Impact of geomembrane cap at closure and continuing leachate recirculation during postclosure.



**Table 13. Analysis of Biodegradable Material Present in Ottawa, Canada, MSW During the 1980s**

| Type                | Percent of Total | Rate of Decomposition |            |
|---------------------|------------------|-----------------------|------------|
|                     |                  | Type                  | Percent    |
| Cellulosic          | 62               | Slow                  | 68         |
| Noncellulosic:      |                  |                       |            |
| Leather, textiles   | 6                | Slow                  | 32         |
| Food and yard waste | 32               | Rapid                 | 32         |
| <b>Total</b>        | <b>100</b>       |                       | <b>100</b> |



**Figure 13. Trail Road Landfill site plan.**

The unusual aspect of the Trail Road Landfill is that it was operated in a manner that very closely simulates the performance of a landfill bioreactor, even though no leachate recirculation was used at the time. Leachate recirculation is now being used in lined Stage 3.

Stage 1 has dimensions of roughly 1,600 ft by 1,600 ft but is only a maximum of 68 ft high at its center. The landfill received an average of just over 900 tons/day of MSW each operating day, or about 285,000 tons/yr. It was constructed in a series of horizontal lifts that were only 8 ft high but were 200 ft wide and 1,600 ft in length. A cross section and plan view of the lift sequence plan are shown in Figures 14 and 15. Each lift was covered with 6 to 12 in. of daily and intermediate cover, which consisted of permeable, silty, fine sand. The ratio of refuse to daily soil cover was measured and determined to be about 5.5:1 on a volume basis. The amount of time required to complete a 400-ft-wide cycle of an 8-ft-high lift placement was generally 2 to 3 months. Often, two or more such cycles were made before starting the next higher lift, and the total time that each 8-ft lift remained exposed before the next higher lift was placed over it was generally 4 to 6 months. The sequence of filling operations and the year of refuse placement are shown in Figure 16.

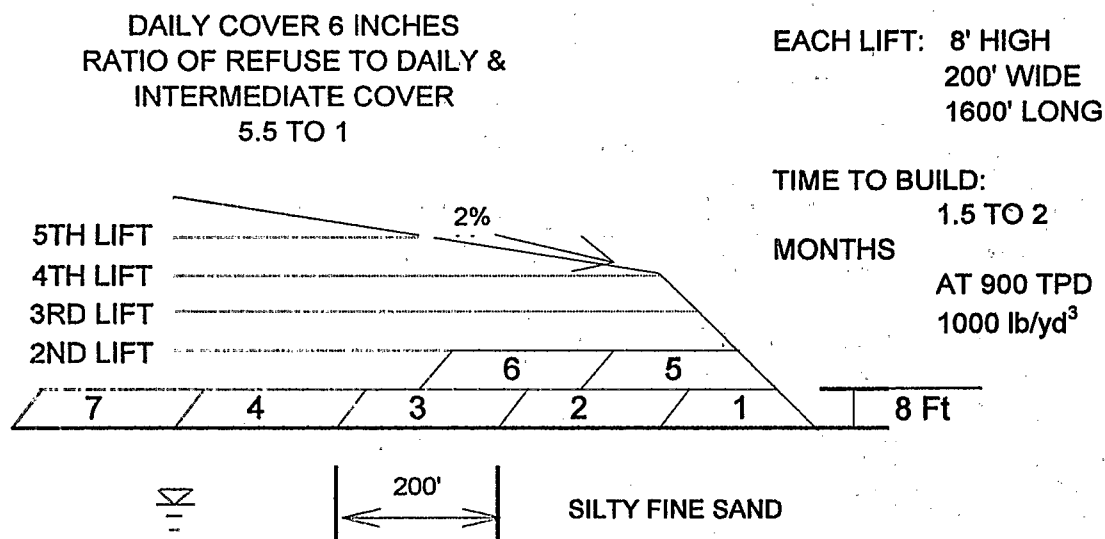

Figure 14. Lift construction (section).

The Stage 1 area of the landfill was filled to capacity in July 1986, and operations ceased after an intermediate cover of 12 in. of silty, fine sand was placed over the landfill. The landfill contained 1,780,000 tons of MSW as weighed at the landfill scales between 1980 and 1986. A synthetic geomembrane cap (60-mil high density polyethylene [HDPE]) and final cover system was placed over Stage 1 2 years later, in July 1988, as shown in Table 14. The design of the cap and final cover system is shown in Figure 17. A grid system of parallel gravel-filled gas collection trenches with perforated polyvinyl chloride (PVC) pipes was installed under the cap at a spacing of about 400 ft on center. These trenches intersected at about 16 to 18 locations on the landfill where biogas was vented and flared from riser pipes. In September 1991, the riser vents were cut off and sealed and the perforated collection piping system was physically

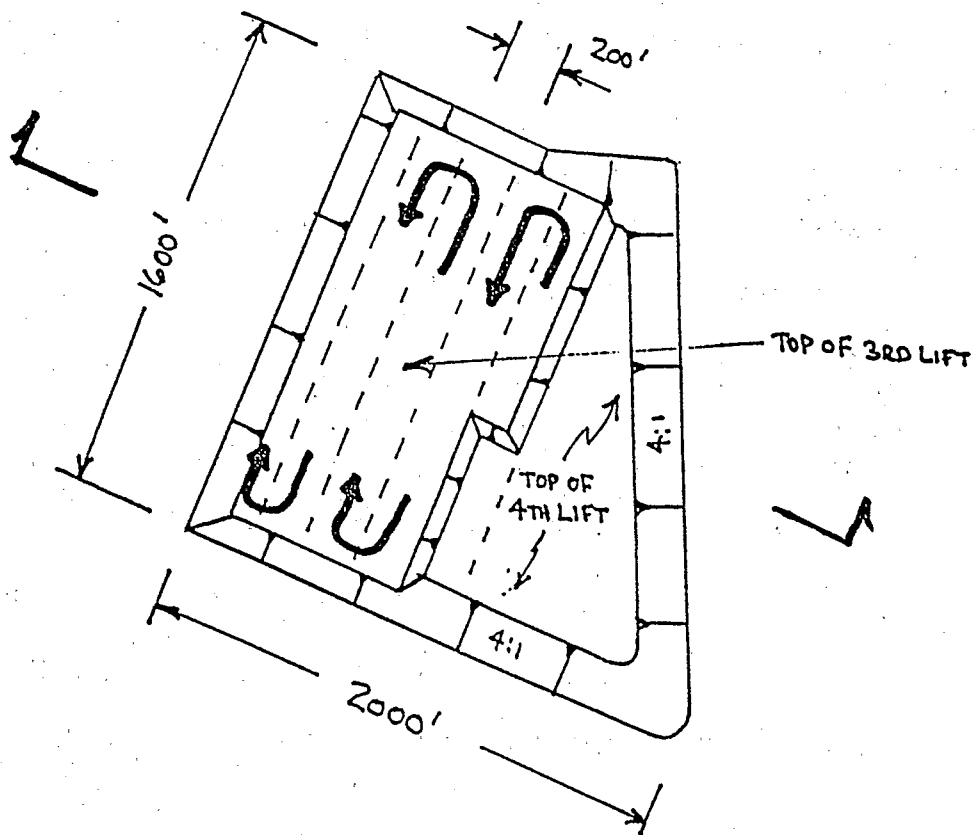

Figure 15. Trail Road Landfill lift construction plan.

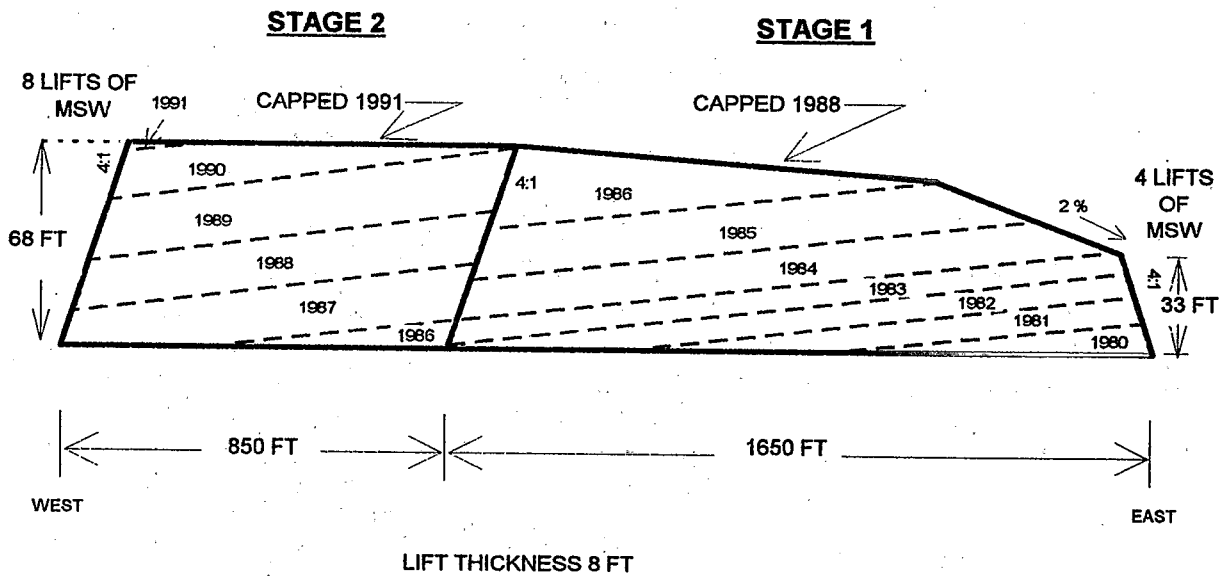
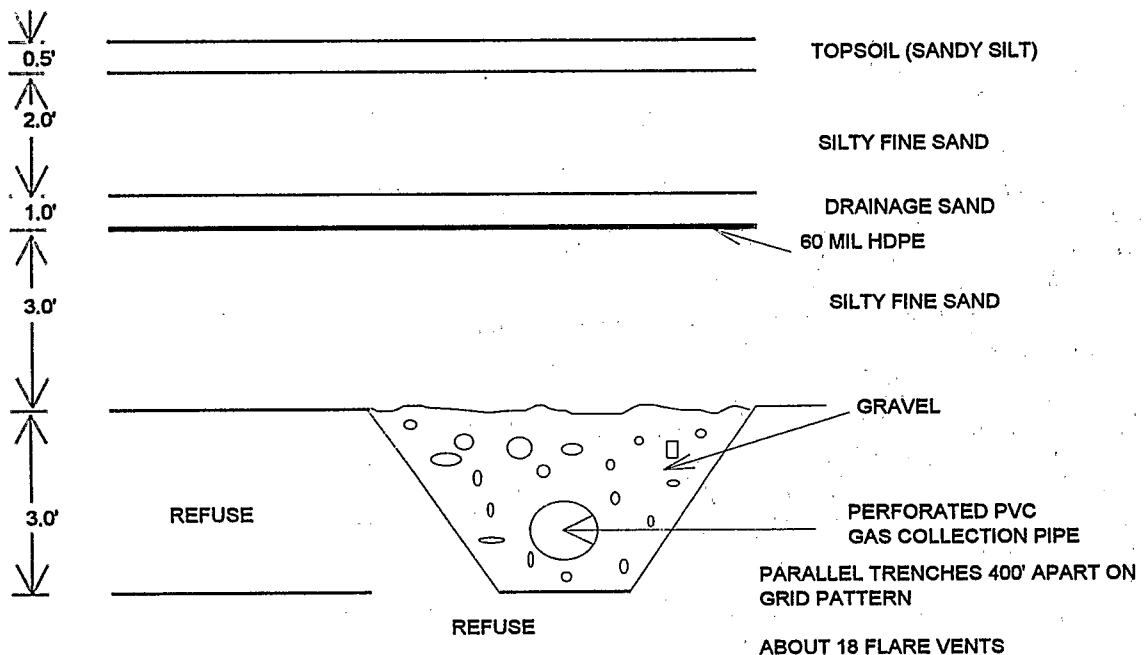

Figure 16. Stratigraphy and age of refuse in Stages 1 and 2.

connected to the active gas recovery system in Stage 2, which used a central blower facility to draw biogas from both stages to a flaring facility shown in Figure 13. The flow of gas from Stage 1 was metered in late 1991.

**Table 14. Sequence of Events for Stage 1 of the Trail Road Landfill**

| Event   | Date           | Duration (yr) |
|---|----------------|---------------|
| Start of operations   | May 1980       | 6.1           |
| End of operations; place intermediate cover over top                                  | July 1986      | 2.0           |
| Install 60-mil HDPE cap, gas trenches, and flaring vents                              | July 1988      | 3.2           |
| Seal off gas vent flares, and begin blower extraction to flaring facility for Stage 2 | September 1991 | 2.0           |
| Conduct exploration of Stage 1  | August 1993    |               |
| <b>Total elapsed time</b>   |                | <b>13.3</b>   |



**Figure 17. Stage 1 final cover system.**

Ottawa, Canada, receives about 32 in. of precipitation per year: 23.0 in. falls as rain at the rate of 3.1 in. per month for 7.5 months of the year, and the rest falls as snow when the landfill surface is frozen during the cold winter season. Because evapotranspiration is very low in Ottawa and the soils used for daily and intermediate cover were so permeable, the net infiltration into the landfill between April and November of each year was estimated to be at least 10 in. The spring thaw in March also was calculated to contribute a one-time slug of about 4 in. of infiltration.

Due to the high rate of net infiltration, each 8-ft-thick lift is believed to have received enough added moisture in 4 to 6 months to reach field capacity before the next vertical lift was placed over it. This process was repeated lift after lift for 6 years until Stage 1 reached its permitted final grades.

As a result of these circumstances, the MSW in Stage 1 of the Trail Road Landfill essentially remained at field capacity for a duration of 8 years until the geomembrane cap was installed in the summer of 1988. All excess infiltration during that period percolated through the landfill and discharged as leachate into the underlying ground-water table. A significant plume of contaminants developed in the ground water below the landfill and, during the mid-1980s, began migrating downgradient, where it was detected in numerous ground-water monitoring wells installed to address the ground water contamination issue. Stage 1 was believed to still be at a field capacity moisture content of 45 to 50 percent when it was capped. No additional moisture is believed to have entered Stage 1 of the landfill after July 1988.

In August 1993, the Regional Municipality of Ottawa-Carleton and its landfill design engineers, J.L. Richards and Associates, Ltd., conducted a landfill mining feasibility study for Stage 1. Available data on the construction and performance of Stage 1 were collected and reviewed, including an analysis of projected and measured landfill gas production (see Figure 18). In addition, three 10-in. diameter auger test probes were drilled through the HDPE cap at the plan locations shown in Figure 13, using continuous-flight, hollow-stem augers that had a plugged bit. Two of the probes penetrated the fill and were terminated in the glacial outwash deposits. The augers were used to perform continual sampling of the refuse. This was accomplished not by spinning the augers so material from the bottom of the hole could be carried to the surface on the vanes where it would be sampled but, instead, by first reaming the hole to a predetermined depth; removing the augers from the hole to clean them off; reinserting the clean auger stem and lowering it to the bottom of the hole without turning the augers; advancing the auger stem about 12 in. into the refuse at the bottom of the hole while turning a minimal number of revolutions; then pulling the entire auger flight without rotation to obtain a refuse sample from the vane directly above the bit. Various gas detection equipment was used to monitor the amount of methane in the auger probe hole as well as in the refuse samples taken of the auger vanes. The materials and conditions encountered in the auger probe were carefully logged, and samples were obtained for laboratory testing. The degree of biodegradation that was observed as the auger probes were advanced was based on the observed physical condition of the refuse described in Table 15. It was possible to date the age of the refuse encountered at most locations from dated pieces of newspaper or magazines found in the auger samples, and these data correlated well with the known construction sequence of the landfill.

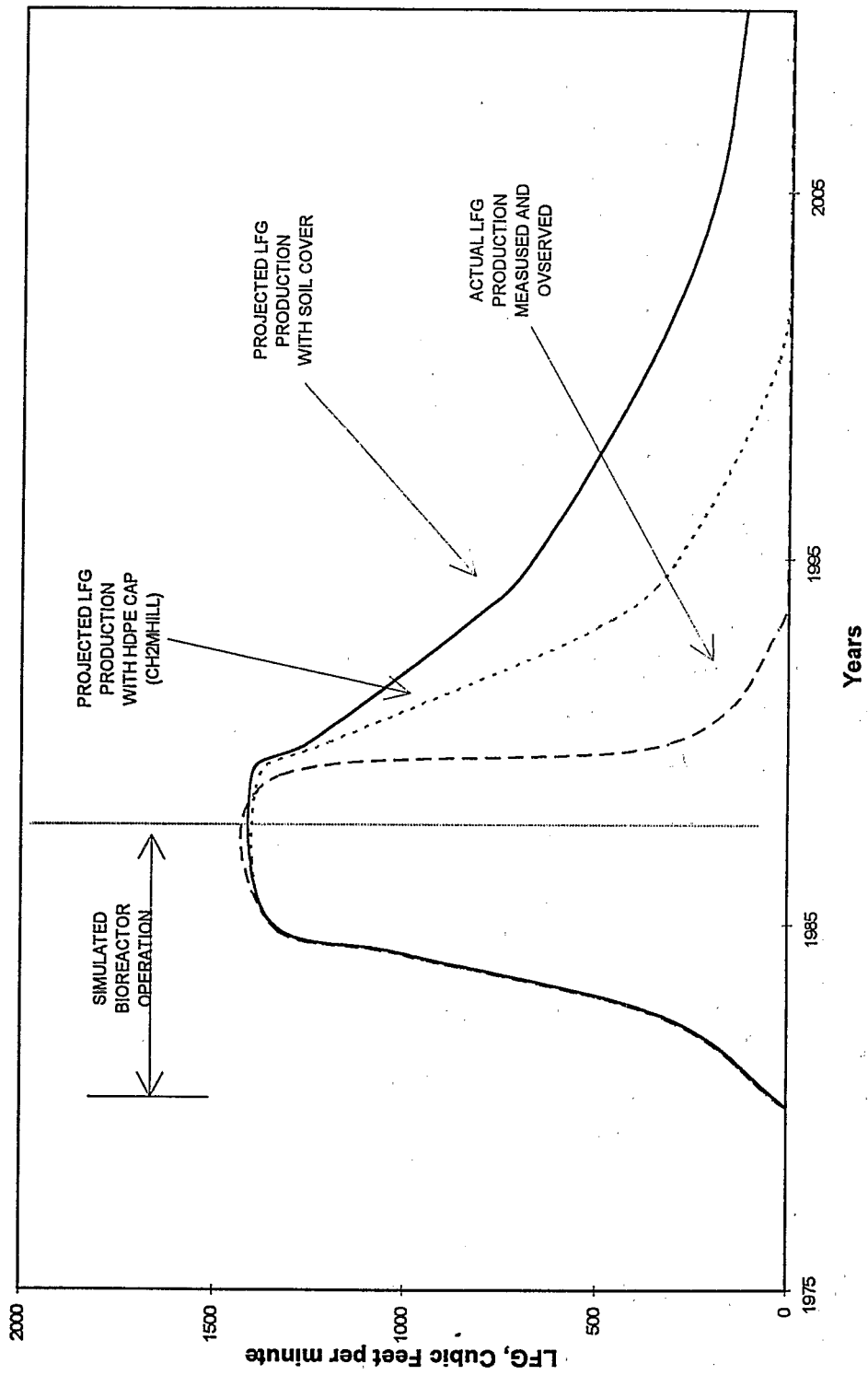

Figure 18. Trail Road Landfill Stage 1 LFG production.

**Table 15. Scale of Estimated Decomposition of Biodegradable Organics in a Landfill**

| Estimated Degree of Decomposition (%) | Description  |
|---------------------------------------|--|
| 0                                     | Condition at placement.  |
| 30                                    | All food wastes, vegetable and plant matter, grass clippings, and leaves completely decomposed and converted to humus or grit. All paper products intact, moist and slightly soft, little or no discoloration. Very strong anaerobic odor evident. Wood fragments intact; no discoloration. Grit content (fines) about 25 percent. Wastes very warm.   |
| 50                                    | Paper products soft, moist to wet, and break apart easily, yellow to black staining evident. Newspaper and cardboard intact, wood slightly discolored and slightly soft, anaerobic odor evident. Increase in grit content (fines) of wastes about 30 to 40 percent. Wastes warm.   |
| 70                                    | Most cellulosic material degraded to a gray color, and fibrous, friable consistency. Only small fragments (less than 10 percent) of cardboard and newspapers still present, but very soft and fragile. Most biodegradable textiles black and nearly decomposed, wood fragments dark brown to black, soft and spongy. Mild to weak anaerobic odor, grit content (fines) of wastes about 50 to 60 percent. Wastes slightly warm. |
| 80                                    | Most cellulosic material degraded to light gray and mixture of fibers and grit. No remaining pieces of newspaper or cardboard. Wood fragments black and friable. Weak to no anaerobic odor. Grit content (fines) of wastes over 70 percent. Wastes cool.   |
| 100                                   | All organic material decomposed to gray humus and grit. No anaerobic odor. Wastes cold.  |

At the time the field exploration program was conducted in Stage 1, approximately 5 years after placement of the HDPE cap, the landfill was found to be completely dormant with virtually no microbial activity in progress. The refuse samples taken from the landfill were odorless, and no odors were detected in the vicinity of the open auger probe shafts. Only a small amount of methane and anaerobic odor was encountered in one of the gas collection trenches at the moment that it was penetrated by the auger, but even that was less than 25 percent of the lower explosive level (LEL). That biogas dissipated in 2 to 3 minutes and could not be detected again. Methane was not detected at most of the sampling points of the auger probes, with only three or four exceptions where a methane reading of less than 10

percent LEL was recorded. The Stage 1 portion of the gas recovery system was turned off (valve closed) prior to the field exploration program, so its operation could not affect the conditions encountered in the landfill. The dramatic decrease in biogas production in Stage 1 after closure is depicted in Figure 18. In addition, the refuse in the landfill was found to be very dry (see Figure 19). The average moisture content of the degraded MSW was only about 22.5 percent. The refuse was driest immediately below the cap, where the gas recovery system operations undoubtedly contributed to the excess dehydration of refuse. At depths of more than 10 ft below the base of the final cover system, the moisture contents of the MSW appeared to be consistently around 25 to 28 percent. These moisture contents were all well below the level needed to sustain further microbial activity.

The range of biodegradation of the organics in Stage 1 was found to vary from 20 to 30 percent complete in one isolated pocket to 100 percent complete in the older portion of the fill. The average degree of biodegradation that had been achieved in Stage 1 prior to cessation of microbial activity due to moisture starvation was estimated to be about 75 percent complete. A reasonably good correlation was found between age of the refuse and degree of biodegradation (see Figure 20). All refuse that had been in place more than 10 or 11 years was completely biodegraded. Extrapolation of the field data, however, along the correlation line of best fit suggests that virtually no further degradation occurred in the wastes after about 1991. This means that the biodegradation process effectively came to a halt within 3 years after placement of the cap. The data in Figure 20 were adjusted to approximate the rate of biodegradation as it occurred prior to 1991 (see Figure 21). The adjusted data suggest that under ideal conditions for biodegradation of MSW, such as those that might exist in a landfill bioreactor with leachate recirculation, 100-percent biodegradation can be achieved in 8 to 10 years once field capacity has been reached and maintained.

Finally, a mass-balance analysis was performed for Stage 1 of the Trail Road Landfill as presented in Figure 22. The calculations indicate that since the time of initial waste placement, the MSW has undergone a 26-percent decrease in mass. This corresponds to a 75-percent degree of biodegradation. If 100-percent biodegradation were to be achieved, the data and analysis suggest that the total reduction in mass should be about 35 percent.

## Findings

1. Under RCRA, the average length of time between initial refuse placement and closure with a final cover system containing a geomembrane will be shortened to about 5 to 10 years. As a result, it is unlikely that most new landfills will reach field capacity prior to closure.
2. Under RCRA, it appears that achievement of a 40-percent recycling goal will not significantly affect the total percentage of biodegradable organic material in landfilled MSW compared with historical waste composition. The characteristics and properties, however, of the biodegradable fraction of the refuse will change significantly with the elimination of yard wastes. The behavior of the biodegradation process will be dominated to a much greater extent by the methanogenesis of slowly decomposing cellulosic matter. It appears likely that when this finding is coupled with the "rush to closure" philosophy described above, the total amount of biodegradation that will



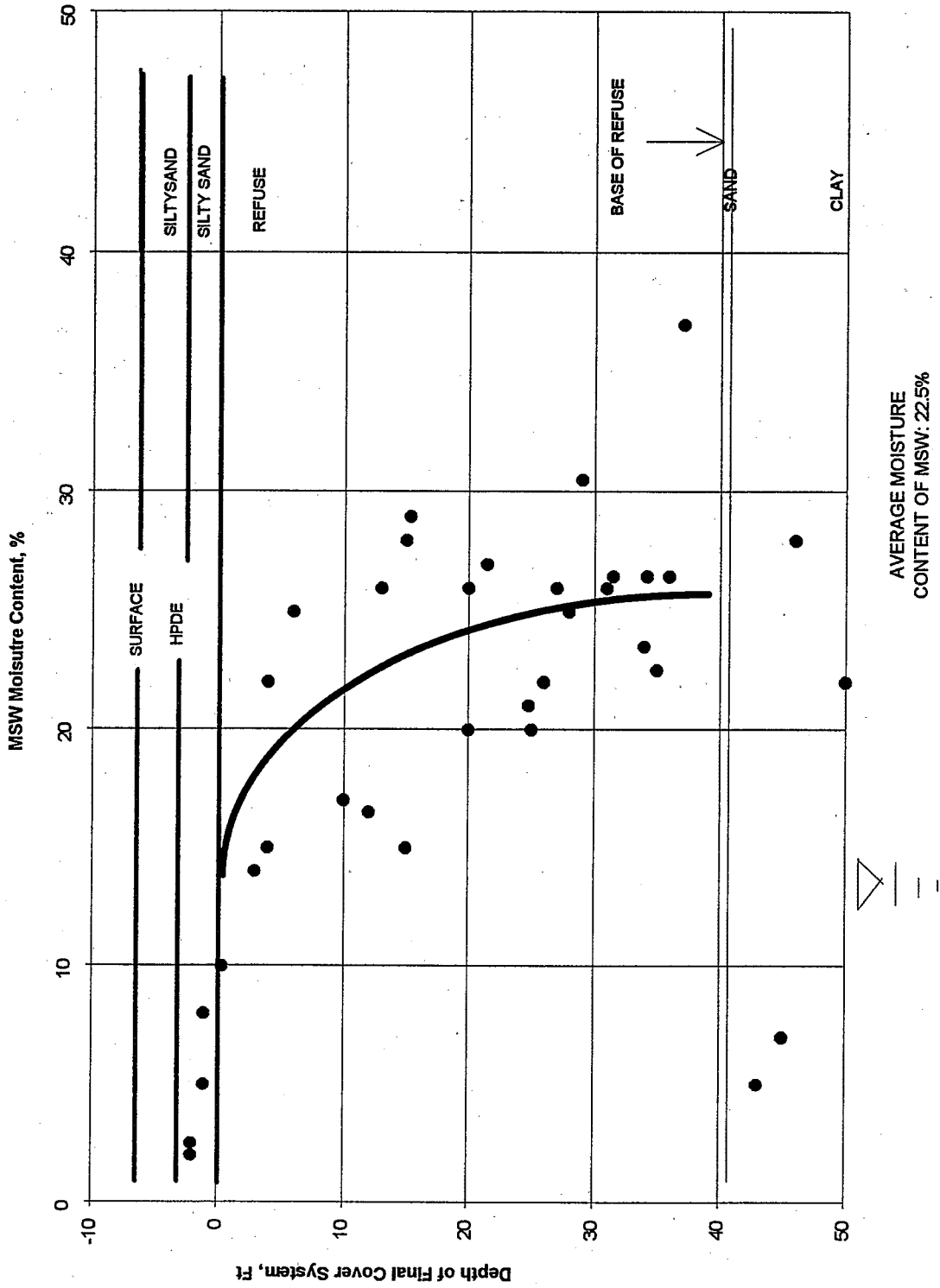

Figure 19. MSW moisture content as a function of landfill depth.

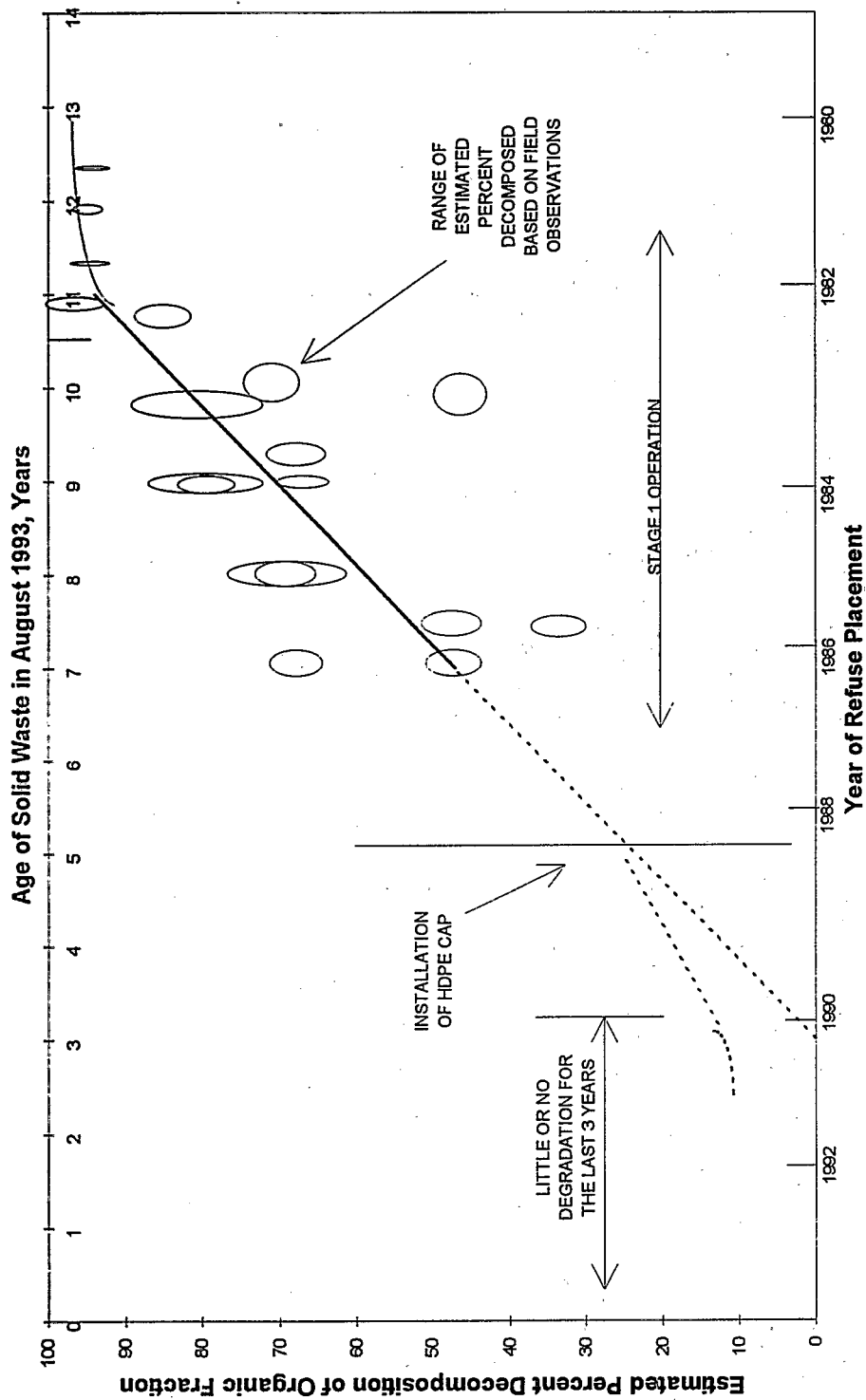

Figure 20. Trail Road Landfill correlation of refuse age to degree of biodegradation.

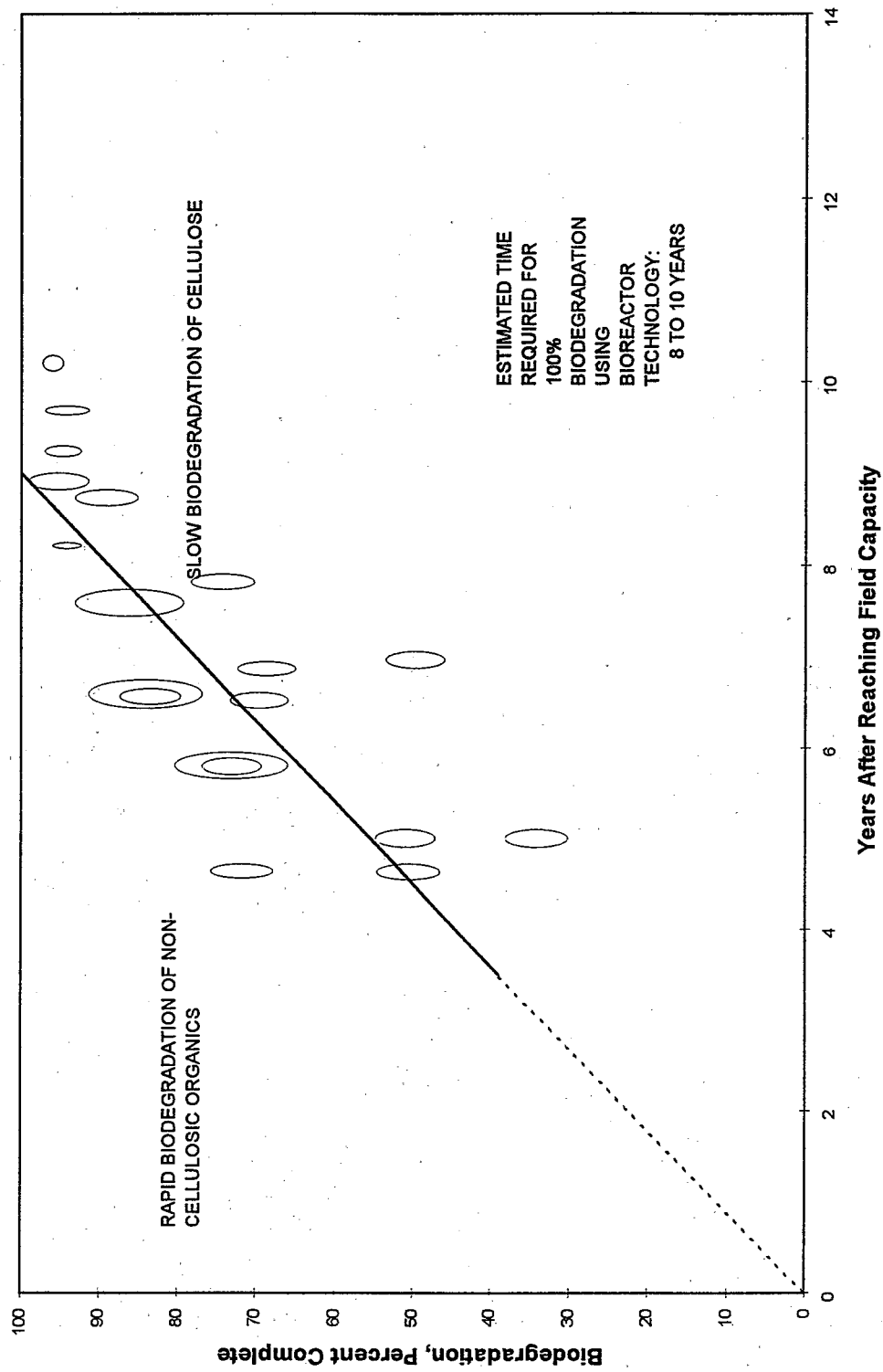

Figure 21. RCRA landfills with bioreactor technology.

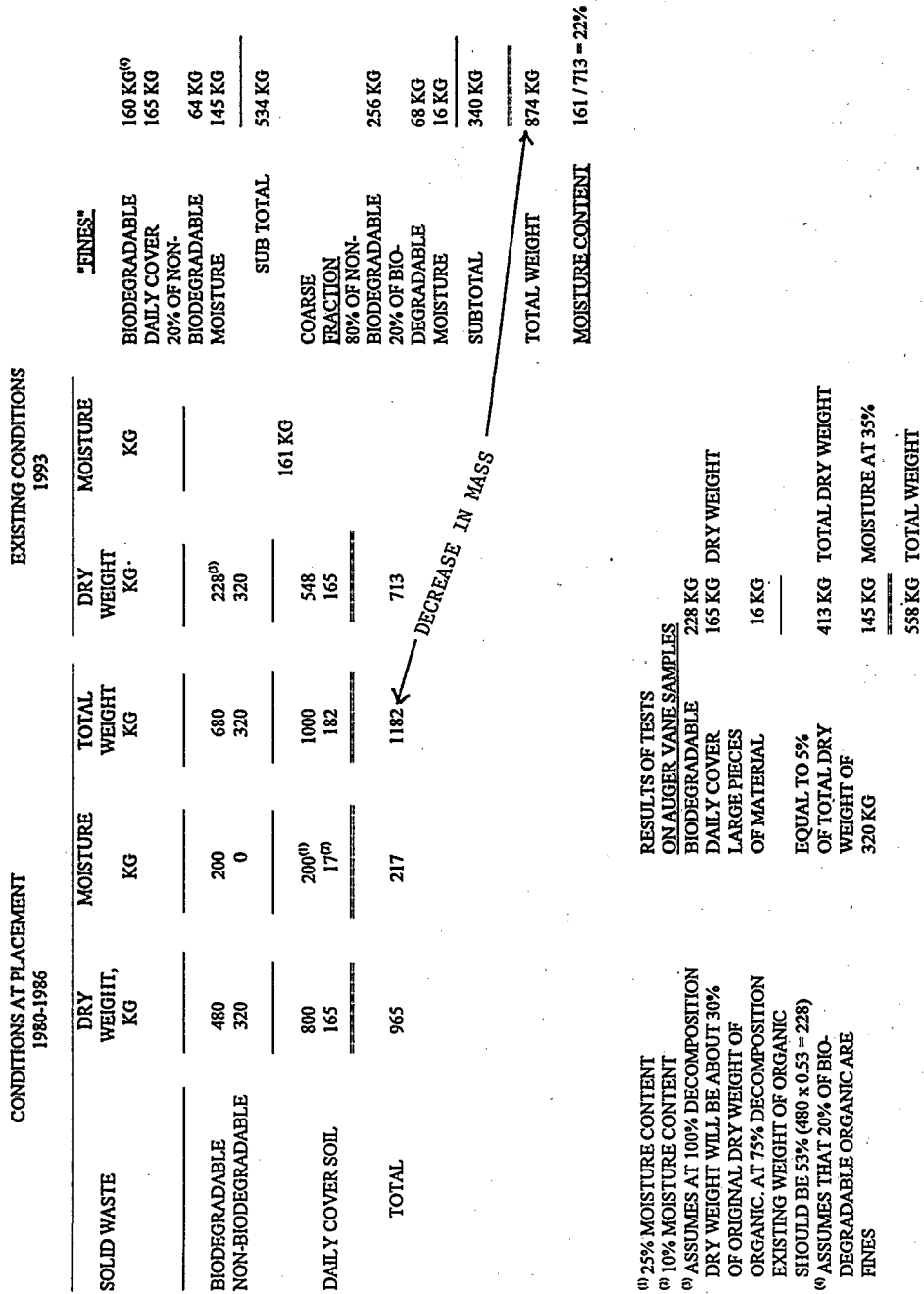

Figure 22. Trail Road Landfill mass-balance diagram for Stage 1.

occur prior to closure, even in the best of circumstances with leachate recirculation in place during landfill operation, probably will not exceed 20 to 30 percent complete.

3. The moisture content of the landfilled MSW must be sustained at or above 34 percent for the entire process of methanogenesis to be carried to completion. If the landfill moisture content falls below 34 percent at any time, the partially completed anaerobic biodegradation process will cease due to moisture starvation.
4. A biological water demand of 33 percent is required to anaerobically biodegrade cellulose during the methanogenesis process. This is an actual system water loss that must be compensated for in the landfill bioreactor. In addition, another 20- to 30-percent system water loss can occur if significant amounts of saturated biogas are vented to the atmosphere, flared, or escape through the daily and intermediate soil cover during the entire time that methanogenesis is occurring. Both system water losses, totaling 50 to 65 percent, will occur concurrently. These system water losses must not lower the landfill moisture content below 34 percent, or microbial activity will cease before nearly 100 percent complete biodegradation occurs due to moisture starvation.
5. The actual system water losses that will occur in a landfill bioreactor will be less than 50 to 65 percent because:
  - Only 65 percent of postrecycle landfilled MSW will consist of biodegradable organics, of which over 80 percent will be cellulosic material.
  - Most cellulosic products such as paper and cardboard generally do not contain more than 70 percent pure cellulose fiber.
6. Once field capacity is reached throughout the landfill, the total amount of additional water that must be added to achieve nearly 100-percent biodegradation and to compensate for system water losses due to microbial consumption and release of saturated biogas in vents or flares appears to be about 1.0 to 1.5 times the amount of water originally needed to raise the initial moisture content of the refuse from 25 percent to field capacity of 45 to 50 percent.
7. Because it will take approximately 1.75 in. of water per foot of landfill thickness to raise the moisture content of refuse from an initial moisture content of about 25 percent to field capacity of 45 to 50 percent in landfills now experiencing an initial refuse placement density of about 1,200 lb/yd<sup>3</sup>, the estimated makeup water needed to compensate for biological water demand and vented biogas system water losses appears to be approximately 1.8 to 2.6 in. of water per foot of landfill thickness. In a landfill cell that has an average thickness of 50 ft, the amount of makeup water needed to compensate for system water losses would be approximately 90 to 130 in. of water over the accelerated 8- to 10-year period that it would take to achieve nearly 100 percent complete biodegradation using bioreactor technology. This works out to an average of between 9 and 15 in. of makeup water per year. A direct correlation exists between how rapidly complete biodegradation can be achieved in a landfill bioreactor

between how rapidly complete biodegradation can be achieved in a landfill bioreactor and the rate at which moisture must be added to the landfill to compensate for system water losses.

8. In a landfill bioreactor, if field capacity of the MSW is reached prior to closure, the amount of additional infiltration that enters the surface of the landfill prior to closure and is recirculated in the form of collected leachate will contribute to meeting the biological water demand of the microorganisms. The total quantity of excess infiltration, however, probably will not be of sufficient quantity over just a few years to meet the total postclosure biological water demand needed to achieve nearly 100-percent biodegradation. Recirculation of leachate after closure may prolong the biodegradation process for 1 or 2 years longer than the 2 to 3 years that would otherwise occur, but leachate discharge from the landfill will eventually stop as this recirculated leachate is consumed by microorganisms, and water starvation inevitably occurs.
9. In a landfill bioreactor, if field capacity of the MSW is not reached prior to closure, there will be insufficient moisture within the landfill to meet biological water demand for complete biodegradation. Any small discharge of leachate will stop shortly after the geomembrane cap is installed, and all microbial activity will probably come to a halt in less than 2 years.

#### **Implications for Municipal Solid Waste Landfill Bioreactor Technology and EPA Regulatory Policy**

There are two clear alternatives for addressing the stated closure/postclosure issues:

1. Postpone closure after reaching final grades for a specific time to allow the bioreactor technology process to be advanced from no more than 30-percent biodegradation at closure to nearly 100 percent complete biodegradation before either installing a geomembrane cap and final cover system or conducting landfill mining. Design the landfill to allow infiltration through the landfill surface to provide enough water to raise the moisture content of the MSW to field capacity and to retain it as close to that level as possible for 8 to 10 years while using leachate recirculation to promote the biodegradation process and also partially compensate for system water losses.

If the rate of infiltration is too slow to keep up with biological water demand, it may prove necessary to add leachate from another source or to add clean water, such as retained stormwater runoff, to the leachate recirculation system to compensate for system water losses. Other options for providing bioreactor makeup water, such as codisposal of sewage treatment plant sludge, should also be considered prior to the start of waste placement in a landfill bioreactor cell.

2. Close the landfill on schedule as now required by RCRA, and install the geomembrane cap and final cover system. Prior to closure, supplement the amount of infiltration occurring by adding and recirculating water from an external source, such as retained stormwater, along with leachate to bring the MSW moisture content to field capacity.

Continue to add clean water or leachate from external sources after closure as required to sustain the landfill moisture content as close to field capacity as possible, but always above 34 percent, so that leachate recirculation can be continued until the biodegradation process is nearly 100 percent complete.

[The page contains extremely faint and illegible text, likely bleed-through from the reverse side of the document. No specific content can be transcribed.]



# **Landfill Bioreactor Design and Operation: International Perspectives**

---

David J.V. Campbell  
AEA Technology, Oxfordshire, England

---

## **Abstract**

This paper discusses current landfill practices and suggested methodologies for enhancing landfilled waste stabilization processes. Emphasis is placed on recirculation of leachate/water to maintain waste moisture content close to field capacity while not compromising the need for high quality leachate control at the base of the site. Methods are also advocated for optimizing waste degradation temperatures, and, importantly, consideration is given to the fate of inorganic species still present following biological stabilization. The equilibration of these species with the adjacent environment must form a part of the complete management of landfill sites. The paper concludes with a brief review of selected research studies relevant to enhancing understanding of bioreactive processes for landfilled waste.

## **Landfill Practices: Enhanced Stabilization**

Current recommended design and operational practices throughout Europe and in many other parts of the world tend to act against the main factors that support rapid degradation of organic biodegradable wastes. Three critical factors determine the rate of decomposition and stabilization of deposited wastes, while other important but perhaps less critical factors also play a part. The three major factors are:

- Waste moisture content and uniformity of moisture movement through wastes.
- The temperature waste deposits maintain throughout the anaerobic degradation phase.
- Waste particle size, which affects surface area availability to the anaerobic bacteria, which degrade organic matter in the waste.

Among other important factors is the presence (or absence) of particular waste materials (and daily cover soils), which may act as a pH buffer to maintain optimal methanogenic conditions or may inhibit microbial processes (e.g., the presence of excessive concentrations of heavy metals). The rate of degradation of particular components in the deposited waste also is important. It is generally accepted that mixed waste components (e.g., vegetable matter, paper, garden wastes, inerts) are preferable to, say, solely paper wastes in supporting more rapid degradation processes. The extent to which wastes are homogenized during compaction, the type and amounts of daily cover materials used, as well as depth of deposits also are important.

---

The preference for operating fewer, large landfills with high waste inputs, coupled with requirements for progressive infilling and restoration of sites, reduces the potential for uptake of moisture through infiltration of precipitation. The almost universal requirements for complete containment of sites, whether with single or multiple mineral or synthetic liners, eliminates any potential subsurface infiltration that might contribute to moisture uptake by waste. In conjunction with designs for containment landfills, the essential introduction of basal leachate drainage systems similarly reduces zones within lower waste deposits that are at or above field capacity. Other more subtle changes, including modified collection practices that reduce the initial moisture content of deposited wastes, support the fact that deposited wastes often remain at low moisture content in modern landfills for long periods following initial waste deposition. Finally, and perhaps most importantly, many current site restoration design specifications do have a major impact in decreasing waste stabilization rates. This includes requirements for domed profiles using low permeability capping materials. Subsurface water drainage systems above these caps are sometimes required to make soils more amenable to quality recreational or agricultural after-uses. Together with evapotranspiration losses from vegetated surfaces, the combined impact is to restrict future infiltration and movement of moisture within and through deposited waste layers.

The generation of elevated temperatures within deposited waste very shortly following initial deposition is important in supporting the rapid growth of anaerobic, and especially methanogenic, microbial populations. High waste input rates, coupled with modern practices of infilling small areas/volumes in meeting progressive restoration requirements, reduce the opportunity for significant contribution to elevated waste temperatures arising from aerobic decomposition processes. Thus, compacted wastes initially are often close to ambient temperatures rather than at 60°C to 70°C (typical aerobic decay temperatures), which may be retained or transferred to adjacent previous deposits. Most landfilled waste, at least in temperate climates, degrades anaerobically within the range of 20°C to 40°C, typical of mesophilic methanogenic processes. In some locations, notably in hot and moist climates, thermophilic methanogenic degradation is more common (55°C to 65°C). The conditions are more conducive to rapid initial aerobic degradation of the readily degradable waste fractions. Equally, there is reduced heat loss from these "fresh" wastes, notably where there are high waste inputs to the site.

These important factors that control rates of waste degradation processes are not particularly novel and peculiar to landfill sites. They have been well characterized for many years in conventional prefabricated anaerobic degradation process plants used to treat a variety of solid and liquid effluents.

These basic 'ingredients' for successful operation of bioreactor systems, however, seem to have been largely ignored by many of those engaged in redefining modern landfill design specifications, where the emphasis has been on developing engineering solutions to reduce or eliminate gaseous or liquid emissions from the landfill site itself.

In some European countries (e.g., Germany, Holland, Switzerland), there is much concern about the potential uncertainties and adverse impacts arising from the degradation of organic waste matter in landfills. As a consequence, there are increased requirements to restrict the future organic content of wastes for landfilling to less than 5 percent by weight. The

emphasis is on waste treatment, including recycling, composting, and pretreatment (e.g., incineration), to achieve this objective, rather than on how the processes of landfilled degradable organic matter may be better controlled and more rapidly stabilized. The goal of enhancing landfilled waste degradation rates must address concerns of both regulators and the general public. Confidence must be increased by demonstrating that both the landfill treatment processes and the emissions produced consequent to those processes can and will be better controlled, if the above "alternative" options are not to become the preferred waste treatment methods in the future.

Despite the above reservations, there is now an increasing and already quite well-developed debate in some European countries about how waste degradation rates may be enhanced while retaining many of the objectives inherent in state-of-the-art engineered containment designs for landfills. This attention has been focused more intensely in recent years. The essential long-term site monitoring now demanded during the aftercare period and before waste stabilization requires a major technical and financial commitment by site operators. Above all, it is being recognized that "sustainability" is an essential ingredient; i.e., we cannot leave the consequences of our waste disposal practices to be managed by subsequent generations.

While enhanced biological processes are essential for tomorrow's landfill bioreactors, to achieve rapid degradation of organic matter in deposited wastes (unless they are to be precluded from being landfilled at the outset), it should be recognized that this activity is only a part, and perhaps a small part, of the total stabilization of landfilled waste. Perhaps of greater interest in the longer term is the eventual fate of many other, largely inorganic, contaminants present in deposited wastes. Many anions such as chloride and sulphate, cations including a range of heavy metals, and ammonia must be catered to in achieving final landfill stabilization. This final stabilization state should be equated with equilibration (not isolation) of the residual wastes and contaminants with the surrounding environment. Indeed, perhaps it is *not* the biologically active phase that will ultimately be important. Most, if not all, of the control measures for managing biologically generated emissions, including leachate and gas collection and treatment, are expected to operate during this phase. Other contaminants, notably heavy metals, are simply retained within the landfilled waste mass by such factors as pH control (encouraging precipitation), ion exchange, and the physical containment provided. These mechanisms ultimately will not exist at some future time once biological processes are terminated and when the containment becomes less effective. Thus, in discussing future bioreactive landfills, as the following discussion concentrates on, we must not ignore the fate of landfilled residues once biological processes near or reach an endpoint.

It is perhaps ironic that attention is now being given to methods for enhancing biological reactivity of wastes, a process that probably occurred naturally, albeit with much less (if any) designed control, in many older landfills constructed some 20 or more years ago. Typically, the duration of the aerobic degradation phase was more significant (and in the past, has led to spontaneous combustion of wastes at a few sites), while surface and subsurface water infiltration were also greater (due in part to poor site containment and restoration standards). Saturated layers of waste were common, often with liquid flow through the site and with loss of leachate beneath site bases. In recognizing that these uncontrolled activities are quite

unacceptable, they are, in essence, similar conditions to those now sought in managing future bioreactor landfills.

Considerable theoretical attention (but as yet few published results from field practice) is now being given to the potential for leachate recirculation as a means to enhance both waste moisture content and liquid movement within wastes, as well as to provide a mechanism for further treatment of highly polluted leachate. The movement of moisture is perhaps of greater importance in transporting both bacteria and bacterial growth nutrients to various waste fractions. In achieving this objective, considerable attention must be given to:

- The design of basal leachate collection systems.
- Encouraging the uniform movement of liquids through wastes.
- The design of leachate injection systems installed beneath site restoration caps and soils.

There has perhaps been greater interest to date in leachate reinjection as a means to treat excess leachate and/or as a means to enhance gas generation for commercial recovery purposes, rather than as a means to enhance waste stabilization time scales. Of course, the two are interrelated, but most site operators only consider the process to be beneficial for leachate treatment or for gas generation rather than reduction of waste stabilization periods.

There are several potential difficulties in adopting bioreactive landfill practices in the United Kingdom (UK). Simply to obtain regulatory approvals to undertake leachate recirculation is difficult, where much of the argument in support of new landfill schemes has to accept the need to prevent significant leachate formation. Indeed, it is likely that any admission that there might be enhanced formation of degradation products through increased bioreactivity would only make the regulatory bodies, as well as the public, more reticent in giving their approval.

There is a need to encourage the more rapid onset of fully methanogenic degradation within recently developed (phases of) landfill sites. This could be advanced by incorporating a partially decomposed and shredded waste fraction to initial base layers, where conditions generated would be more conducive to the rapid establishment of methanogenic populations. This practice has already been adopted at a few sites in the UK, with reported subsequent higher rates of degradation, as measured by waste/gas temperatures and gas production rates, than might otherwise be expected. Limited statistically valid data are yet available, however, to verify that this practice alone is responsible, and it must therefore remain a hypothesis. Equally, the presence of other mixed wastes, including inerts, along with household wastes in compacted deposits, is believed to help reduce the acidity of "fresh" leachates, which otherwise inhibit methanogenic activity.

The practice of leachate recirculation need not be inconsistent with modern landfill design. Conceptual designs (see Figures 1 and 2) meet the requirements to minimize leachate generation rates and restrict, over the short to medium term, the total volume of liquid present above the contained bases of landfill sites (1). Note that natural clay liners are preferred, given the eventual need to allow contaminant release from the base of the site if the landfill repository is not to remain as a perpetual waste (contaminant) storage facility with

continuing potential pollution impacts to the adjacent environment. Over the short to medium term, there is an essential need to recover "high strength" leachate and maintain minimal leachate head above the natural clay liner. Coupling these ideals with leachate recirculation, two critical factors need to be addressed:

- The quality of the drainage system laid above the liner
- The potential for uniform movement of leachate within the deposits

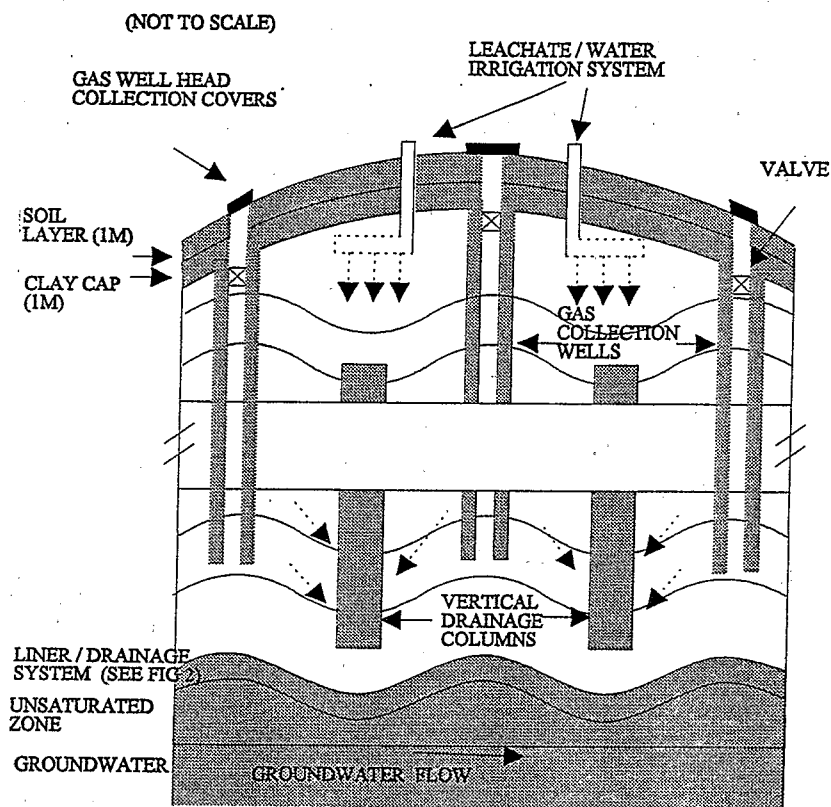

**Figure 1. Conceptual sketch of landfill site design for moisture optimization, containment, and attenuation.**

The collection of leachate by use of sophisticated drainage systems designed to be accessible and operational for many years following site completion has not received much attention at many European landfills until very recent times. Hence, documented evidence of long-term effectiveness of these systems does not readily exist in Europe. The impact of perhaps 30 m to 40 m or more of waste deposits above such systems, causing deformities and blockages (including biomass and sediment buildup) in pipe drainage or leachate injection systems has not been extensively evaluated.

The uniform movement of liquid within the waste mass is currently unlikely given such factors as waste heterogeneity; use of daily (and often low permeability) cover materials; settlement, allowing fissure systems to develop; and the presence of both gas and leachate

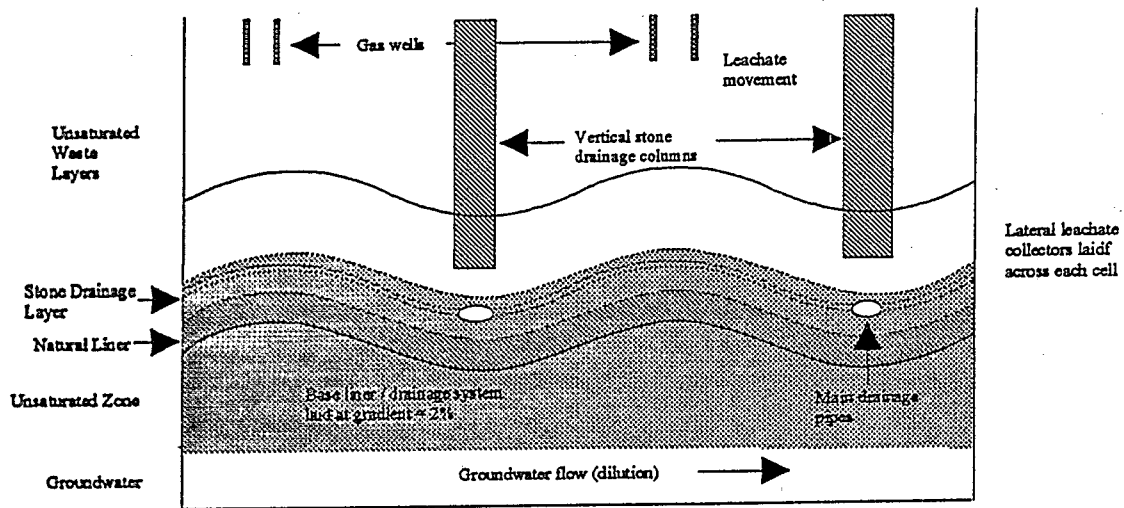

- NOTES  
 Liner thickness 2m (min)  
 Drainage layer thickness 1m (min)  
 Waste layers 3m (max)  
 Main drainage pipes 50m apart (max)  
 Lateral drainage pipes 25m apart (max)

Figure 2A. Sectional sketch of drainage/liner design (not to scale).

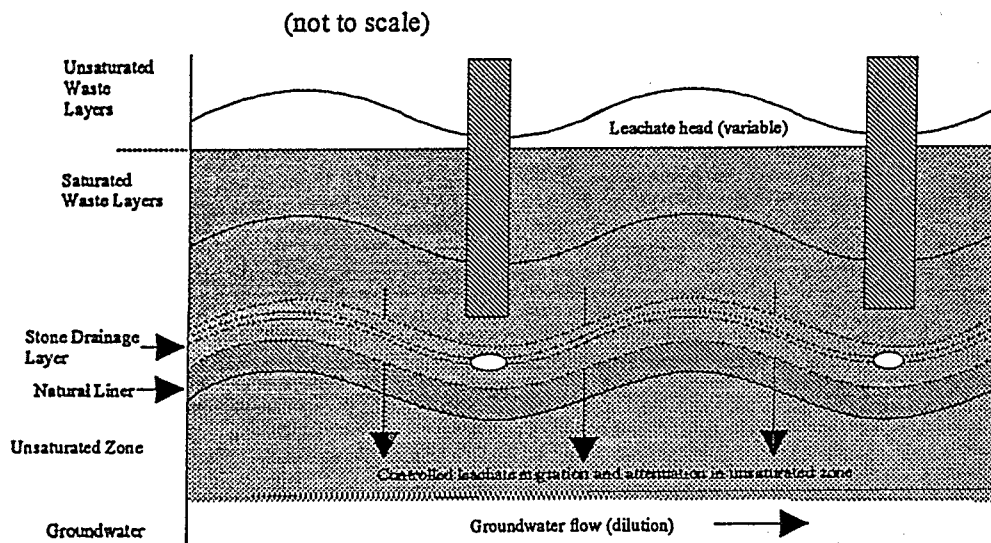

Figure 2B. Sectional sketch of drainage under head of leachate (not to scale).

monitoring and/or recovery wells or chambers. The high compaction of waste, whether achieved by mechanical means during waste emplacement or by physical causes due to the mass of waste deposits, reduces its hydraulic permeability. With care, freshly deposited waste can be wetted to enable field capacity (following compaction) to be reached at an early stage. This creates more uniform moisture distribution at the outset, and, through hydraulic gradients, recirculated leachate/water should continue to be more uniformly distributed.

Designs of leachate recirculation/injection systems must allow for significant settlement of deposits caused both by microbial decomposition and by physical processes. Careful removal of daily cover soils before further waste deposition also enhances uniform movement of liquid through deposits.

In the short to medium term, when "high strength" leachate is generated, it may be preferable to pretreat extracted leachate through an aerobic leachate treatment process before recirculation. This limits the slow buildup of inhibitory contaminants such as ammonia, and especially very acidic, low pH leachates, which prevent the rapid establishment of neutral pH conditions conducive to methanogenic processes. If "fresh" leachates are to be directly reinjected, it may be advantageous to incorporate a pH buffer to maintain near-neutral pH conditions. In temperate climates, some warming (perhaps by heat from landfill gas) of solutions before reinjection may be advantageous to reduce inhibitory cooling effects. Leachates that are pretreated before reinjection beneath the landfill cap would also benefit from oxygen removal, which is also inhibitory to methanogenic processes. While these options may be speculative, they are considered practicable even though increased landfill cost implications are attached. Nevertheless, the potential savings in reduced operation of leachate and gas recovery/control systems and long-term site monitoring are significant, where waste stabilization periods are substantially reduced.

The ability to initiate these practices at an early stage in a site's life must be assessed against ongoing landfilling operations. Several potential interferences with normal operations are likely, not least due to the provision and maintenance of liquid injection ports and the presence of gas recovery wells and general site monitoring facilities. The desirability of having the landfill compactor macerate/pulverize incoming wastes to reduce particle size, itself a potential method for enhancing waste degradation rates, must be judged against the need for the mass of material to be rapidly compacted. There will inevitably be higher fuel and staffing costs associated with increased compaction of much more homogenized and pulverized waste deposits. Waste maceration is particularly important for some of the more intractable biodegradable fractions such as paper and wood. A bioreactive landfill must stabilize *all* biodegradable organic matter in a shorter period, not simply enhance the degradation rates for the more readily decomposable waste materials, if final site stabilization periods are to be reduced. A little methane-rich gas (approximately 5-percent to 10-percent methane concentrations are within the flammability/explosivity ranges) being evolved during the latter stages of a site's life, from slowly degrading waste components, represents almost as significant a local hazard to the adjacent environment as does gas evolved with a 60-percent methane content. At very low gas production rates, it is unlikely that gas management and control systems can continue to function as originally designed.

## Research Studies

The following discussion presents a brief review to highlight a few studies carried out in the UK in recent years. The interpretation of these results may have direct relevance to our understanding of enhanced waste degradation processes. Space limitations of this paper do not permit presentation or a critical review of the results of these studies, which are fully discussed in the referenced reports and papers.

### *Brogborough Gas Enhancement Test Cells*

The primary aim of this program is to study techniques to enhance gas recovery rates and yields in support of commercial use of landfill gas. This is probably the most extensive and expensive of the field-scale experimental studies that have been carried out in Europe. The program, being undertaken by AEA Technology's National Environmental Technology Centre (NETCEN), commenced in 1986, and monitoring is to continue until at least July 1996. This study, supported by the UK Department of Trade and Industry (formerly the Department of Energy), is designed to examine a range of practical gas enhancement techniques by monitoring the total gas generated in each of six large test cells (see Figure 3). Each cell, which contains upward of 15,000 tonnes of waste to depths of approximately 20 m, is contained and isolated from each other by clay forming the base and berm walls (approximately 3 m to 4 m thick). The whole cell array is surrounded by further compacted wastes of a similar nature to try to minimize any adverse impacts due to large temperature gradients across the test cell walls. Each cell contains two gas recovery wells, a liquid injection drainage system immediately beneath the 3-m thick clay cap, a range of monitoring systems; together with a dedicated gas recovery system and flare servicing all six cells. Parameters continuously monitored over the last 6 years since the cell construction phase was completed include gas and leachate quality, gas production/recovery rates, waste/gas temperatures, settlement, gas pressure, and atmospheric conditions. All data are automatically recorded and can be integrated and downloaded to the office via a telephone line. A number of reports have been prepared covering the first and second 3-year contracts, and several papers discussing the results available at that time have been presented (2-4).

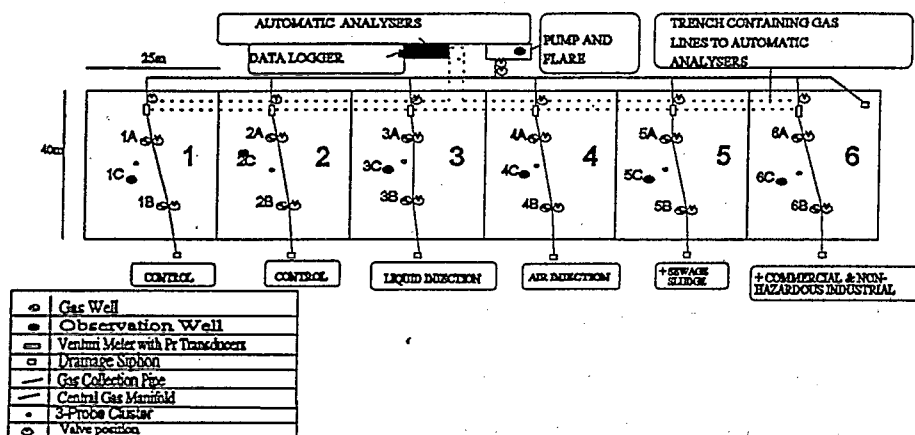

Figure 3. Plan view and schematic diagram of Brogborough test cells.



Cell 1 was designated as a control cell, while the gas enhancement techniques being studied are:

- Low waste density (note that this option was not feasible when cell depths had to be increased to 20 m) (cell 2).
- Recirculation/injection of both leachate and water (cell 3).
- Injection of air to try to raise in-situ waste temperatures (cell 4).
- Codeposition of primary sewage sludge with domestic wastes (cell 5).
- Codeposition of mixed commercial and industrial wastes with domestic wastes (cell 6).

(Note: all cells, except cell 6, contained only household waste as the main waste deposits.)

In addition to the primary objectives of the study to evaluate gas production potential (rates and yields), the test cells have been used in support of several other studies including microbiological evaluations of methanogenic populations (via core samples of waste), odor attenuation studies, and microcomponent comparisons/partition between leachate and gas phases.

Summary data on cumulative gas production rates and yields are shown in Figure 4. It is evident that despite significant enhancement having been achieved, with conditions thought to be conducive to rapid waste degradation, gas production rates in *all* cells continue to increase even approximately 8 years after initial waste deposition. While total gas yields to date (14.5 to 25.3 m<sup>3</sup>/t) represent only 3.9 to 6.8 percent of the theoretical yields (approximately 370 m<sup>3</sup>/t, if 100 percent recovery of all potential gas generated from the conversion of degradable carbon in household waste could be achieved), recent (increasing)

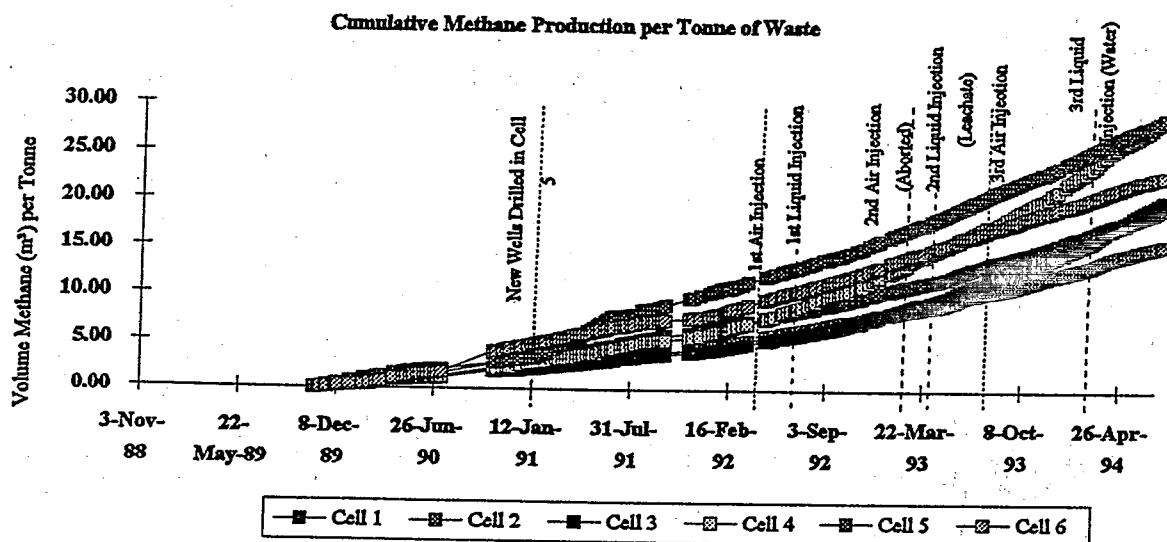

Figure 4. Cumulative methane production per tonne of waste.

gas production rates equate to approximately 4.4 to 9.7 m<sup>3</sup>/t/yr. These rates compare favorably with rates discussed in project reports of other studies. Complete conversion of carbon, and especially 100-percent recovery of methane rich gas, is very unlikely, and a more realistic expectation is approximately 50 percent of theoretical final yields. If the highest rates (cell 4, with aeration) were maintained, complete stabilization would only occur following a further 16.5 years of monitoring. This suggests that "enhancement" is unlikely to achieve a major reduction in waste degradation time scales to less than 10 years, which has been put forward by some people as being feasible.

Waste temperatures (10 m deep) in the most actively degrading cells are around 35°C to 40°C and thus are indicative of near optimal conditions for mesophilic anaerobic degradation. High initial settlement rates (approximately 2 mm/day) at the commencement of cell monitoring reflect substantial initial physical settlement of deposited waste. Current significantly reduced rates (approximately 0.5 mm/day) reflect waste degradation and loss of carbon from the waste mass. Current leachate levels indicate that between 25 and 50 percent (cell dependent) of the waste above cell bases is at saturation. Initial cell designs included leachate collection and removal via a base drainage system, but this method of leachate collection had to be abandoned (with outlet pipes sealed) when unforeseen major increases of daily inputs of waste to the landfill site made access to the outlets impossible. Leachate is now removed intermittently (due to low waste permeability) from the cells by pumping, using one of the installed gas wells in each cell. Most of the monitored parameters are now recorded automatically, with measurements made on an hourly basis. This has been found particularly important when assessing gas recovery quality and production rates, which are significantly affected by frequent variations to atmospheric pressure and other climatic changes. The rate of gas abstraction at each well is closely controlled, largely in response to gas quality changes and to oxygen concentrations in particular.

#### *Other Research Projects*

A significant number of other research projects, some examples of which are summarized below, have been undertaken over the last 15 years in the UK by staff from AEA Technology, mostly on behalf of the UK Department of the Environment.

#### Managed Landfill Research Program

This early study (1978 to 1983) involved the construction of eight large test cells, each containing some 3,500 tonnes of domestic waste to a depth of about 5 m. Included in one test cell was dry, pulverized domestic waste.

Factors studied in the cells included waste particle size, use of different types of compaction equipment and achieved densities, use of different types of daily and final cover/capping materials, recirculation of leachate and/or water, and codisposal of liquid hazardous waste as well as samples of beached marine oil from the Torrey Canyon tanker disaster.

All cells were instrumented with in situ gas and temperature monitoring probes, with continuous monitoring for leachate production rates and, for one cell, with a gas recovery system. Gas and leachate quality were monitored on at least a weekly basis from all sampling points throughout the study, with cell settlement rates monitored on a quarterly basis.

The study permitted accurate correlation of theoretical water budget estimates for sanitary landfill including measurement of absorptive capacity and field capacity values for the waste deposits (5). Temperature gradients and impacts due to ambient temperature fluctuations were monitored, as were gas composition changes throughout and beyond the transition from aerobic conditions to a fully methanogenic state (6). Of particular relevance to options for waste degradation enhancement, it was noted that injection of water (several discrete doses) to wastes, already at field capacity and with fully methanogenic conditions already well established some 2 years after deposition, did enhance initial fermentation and hydrolysis phases of waste degradation. This was evidenced by the production and emission of equivalent volumes of high-strength leachate due to inhibition of methanogenic processes in deposits at depth. It was concluded that the enhanced concentrations of acids generated (enhanced breakdown of complex organic compounds) could not be further degraded during the short residence times available within the relatively shallow (less than 3 m) waste zone where methanogenic conditions existed. The pulverized wastes remained almost inactive for the first 3 years, having been deposited dry, but degradation increased very rapidly once moisture contents increased.

#### Determination of Microbial Populations and Types Present in Landfilled Waste

This title covers a number of studies that involved detailed microbiological examination or evaluation of samples of waste recovered from operating landfill sites or from laboratory column experiments. Work includes evaluation and establishment of test protocols for undertaking biological methane potential (BMP) tests used to evaluate the "state" of landfilled waste stabilization and/or gas production potential.

One study involved collection and examination of a large number of waste samples recovered from a representative selection of landfills with known conditions either supportive or inhibitory for enhanced waste degradation. The range included saturated and hot (45°C) and dry and cold (15°C) wastes from various depths representative of different waste ages (less than 2 to greater than 15 years). In identifying the types and population of methanogens present (7), these were also related to measured gas production rates in samples incubated in the laboratory conditions as similar as possible to those measured in the field.

In other laboratory experiments, "fresh" pulverized wastes (100-kg samples) have been subjected to a number of variables that have an impact on decomposition rates (as measured by gas production rates) including a range of preset moisture contents, water or leachate recirculation at fixed rates, and a range of temperatures. It is essential that results from these studies be treated with caution when translated to field conditions. They have provided evidence, however, that it is the movement of moisture, not just high moisture content itself, within wastes at elevated temperatures that is necessary to achieve rapid waste degradation.

While the use of pulverized waste may also be advantageous, the rapid formation of a more acidic (higher concentrations of long-chain fatty acids) leachate at low pH is inhibitory to methanogenic processes. This may prove to be less of a problem in full-scale landfills where waste depths are much greater and where methanogenic populations can become established more easily.

### Summary

The primary objective in establishing bioreactive landfill sites has to be to minimize the long-term responsibilities of the site owner or operator for monitoring and control of the liquid and gaseous emissions produced during waste degradation. In turn, this will provide regulators with greater assurance that installed controls will function effectively for as long as is necessary. In meeting these requirements, it will be important that:

- The waste is better homogenized to reduce particle size and thus to present greater surface area for microbial attack.
- The waste moisture content reaches field capacity as soon as possible following deposition.
- Moisture movement is encouraged through leachate/water recirculation, and this takes place uniformly and preferably as continuously as possible through all the waste mass.
- The waste mass achieves and maintains optimal temperatures for rapid degradation, whether under mesophilic or thermophilic methanogenic conditions.
- The leachate and gaseous products of waste degradation are efficiently removed from the waste and treated externally. This is essential if we are to conform with site licenses and meet environmental responsibilities, apart from trying not to inhibit further waste degradation processes.

These "ideal" suggested requirements are easier to write down on paper, perhaps, than they are to put into practice at full-scale landfill sites. There is, in Europe at least, a need to demonstrate that landfilling of biodegradable waste is and will remain environmentally acceptable and that each site can be stabilized within our lifetime and not be a burden to future generations. In some European countries, legislators are unconvinced that this goal is feasible and have restricted/prohibited organic deposits to landfill sites.

### Disclaimer

The views expressed in this paper are those solely of the author and should not be taken as being representative of the views of AEA Technology or of any other organization.

## References

1. Campbell, D.J.V. 1992. Implications of site design and operational factors on optimization of landfills as bioreactors. In: Proceedings of BIOWASTE '92, Copenhagen, Denmark (June).
2. Croft, B., and T. Fawcett. 1991. Landfill gas enhancement studies—The Brogborough test cells. Final report. AEA-EE-0156. August 1986-July 1991.
3. McLeod S., S. Davies, and A. Brewer. 1994. Landfill gas enhancement studies—The Brogborough test cells. Second contract, fifth report. AEA/CS/18311002/028/05. August 1993-January 1994.
4. McLeod, S. 1994. Landfill gas enhancement: Large-Scale R&D—The Brogborough test cells. Paper presented at Energy From Landfill Gas—Making It Work Seminar, Solihull, UK (March).
5. Campbell, D.J.V. 1985. Water budget in sanitary landfill. In: Proceedings of International Conference on Landfill Processes, Braunschweig, Germany (September 1982). ISSN 0341-5805.
6. Campbell, D.J.V. 1985. Managed landfill research program—Gas and temperature changes in domestic refuse after landfilling. Report prepared for UK Department of the Environment. Report No. G3400. July.
7. Archer, D.B., E.R. Fielding, and D.J.V. Campbell. 1985. Understanding refuse decomposition processes to improve landfill gas energy potential. Presented at the Third Commission of the European Communities Conference on Energy from Biomass, Venice, Italy (March).

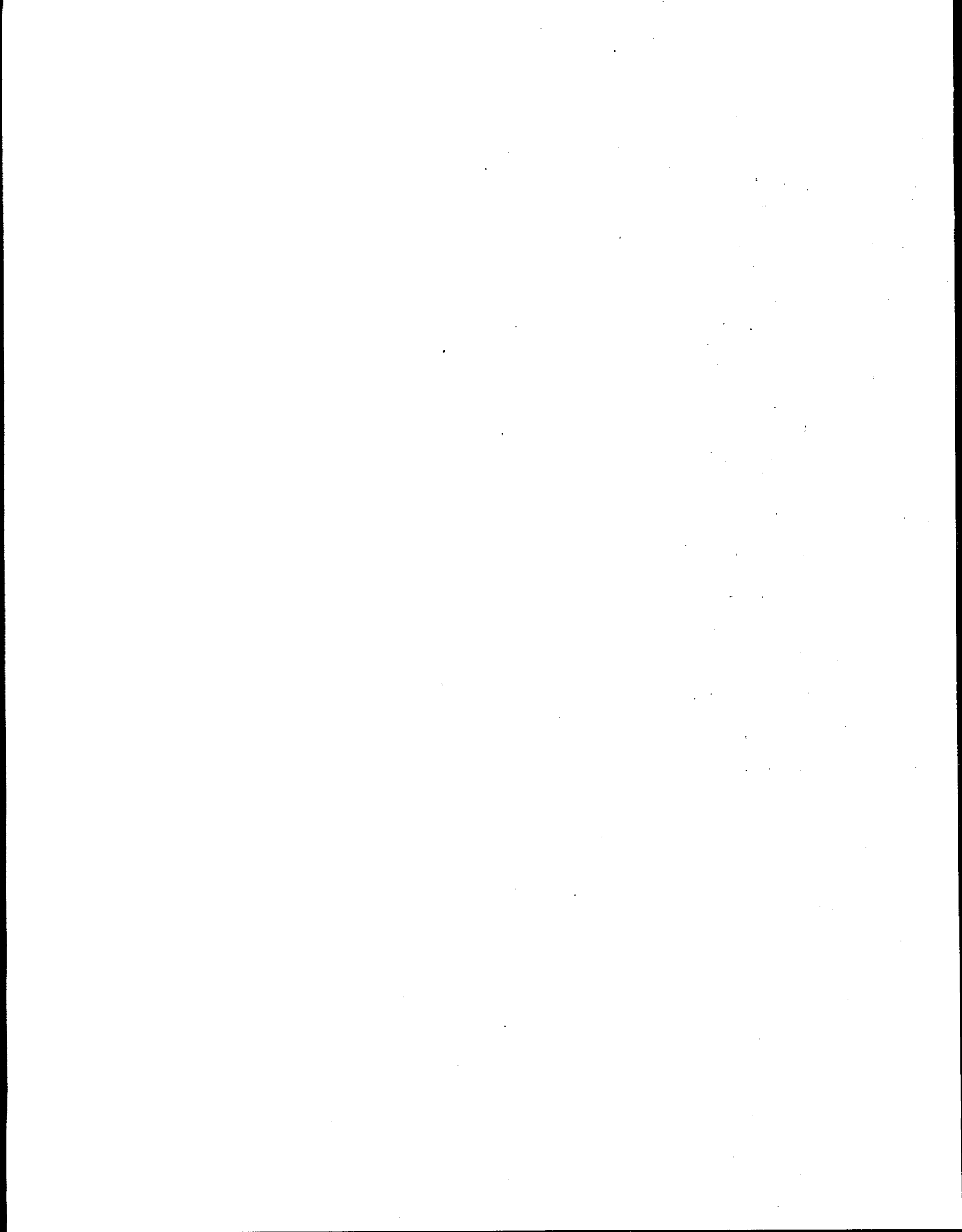

## **Test Cells and Bioreactor Landfills in Sweden**

---

Jan-Erik Meijer

Solid Waste Company of Northwest Scania, NSR, Helsingborg, Sweden

Peter Nilsson

VA-Teknik & Vattenvård AB Consulting Engineering, Brösarp, Sweden

---

### **Introduction**

In Sweden, a coordinated project concerning landfill gas (LFG) generation started about 5 years ago. The first two research periods are now ended, and some interesting results have been achieved. The project is partly financed by the Swedish National Board for Industrial and Technical Development (NUTEK). Test-cells with different kinds of design and wastes have been built at three different locations.

Gas is generated when organic waste is degraded under anaerobic conditions in landfills. The gas consists of methane and carbon dioxide in approximately equal quantities. The energy value is fairly good, about 5.5 kWh/m<sup>3</sup> of LFG. In ordinary landfills, the gas is emitted from the landfill surface to the atmosphere if the gas is not collected. The energy value of the gas makes it interesting to collect and use the gas. Today, several landfills have gas collection systems, with the gas used in boilers, electricity generators, etc. LFG is collected mostly through vertical gas wells with fairly poor efficiency, and the biodegradation of the waste is uncontrolled.

The coordinated project has the goal to answer the following questions:

- Can LFG generation rate and yield be controlled?
- How much total LFG is generated from municipal solid waste?
- How should a landfill be constructed and what types of wastes should be landfilled for maximal LFG generation and collection?

There are a large number of factors that affect landfill internal processes. Those factors can not be studied individually in full-scale experiments. Another problem is the time scale of the processes—anaerobic degradation of solid waste takes a long time, even if good enhancement is achieved. Finally, controlled experiments can sometimes be difficult to combine with ordinary landfill operation.

The factors above have led to some fundamental criteria for the design of the project:

- The experimental variation is based on the operation at the landfills and also the actual waste handling systems. The overall function depending on the
-

landfill type is studied, not necessarily the variation of a single factor or technique.

- The physical systems under study have been placed and designed so that they will be preserved over at least a 10- to 15-year period after this research activity, to the benefit of future research and development.
- The experiments are managed by waste management organizations, based on and integrated with their own landfill operations.

The ongoing coordinated project has been divided into 12 test cells for LFG generation, which means that many alternative tests can be made. The test cells have been filled with waste of different kinds (mixtures), and other variables have been waste compaction and the effect of temperature and moisture content on LFG generation rate. The project is unique in the world. Nowhere else have so many test cells been put together in a coordinated project.

Figure 1 presents the time schedule for the test cell constructions, special studies, and monitoring so far. In 1995, scientific evaluation of the project will be made by NUTEK before further monitoring will be granted. For that reason, 1995 will be a year with plain monitoring and without carrying out any special studies. The three parts have very much been demonstration projects for the landfill industry in Sweden.

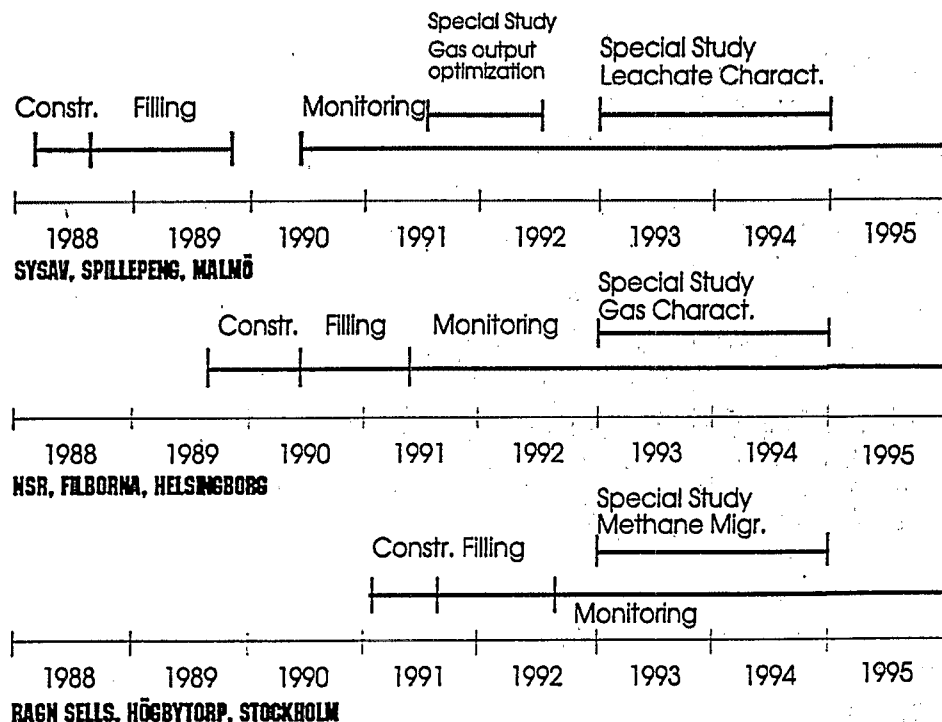

Figure 1. Diagram showing time for construction, waste filling, and monitoring at the three locations of the Integrated Test Cell Project.



The results and the experiences of these test cells have lead to the construction of bioreactor landfills or "biocells," at more than 30 locations in Sweden. In some of these, perhaps, the designs of the cells are fairly simple, but the tendency is clear that this development is going on and will be expanded in the near future.

### Bioreactor Landfill Design

The basic design of the Swedish test cells and the full-scale cells probably have some of their origin from the waste cell constructions at Packington Estate, outside of Birmingham, England. The Brogborough test cells in England, which were constructed shortly before the test cells in Sweden, also have a role in the design of the Swedish test cells. The basic design of a waste cell is presented in Figure 2.

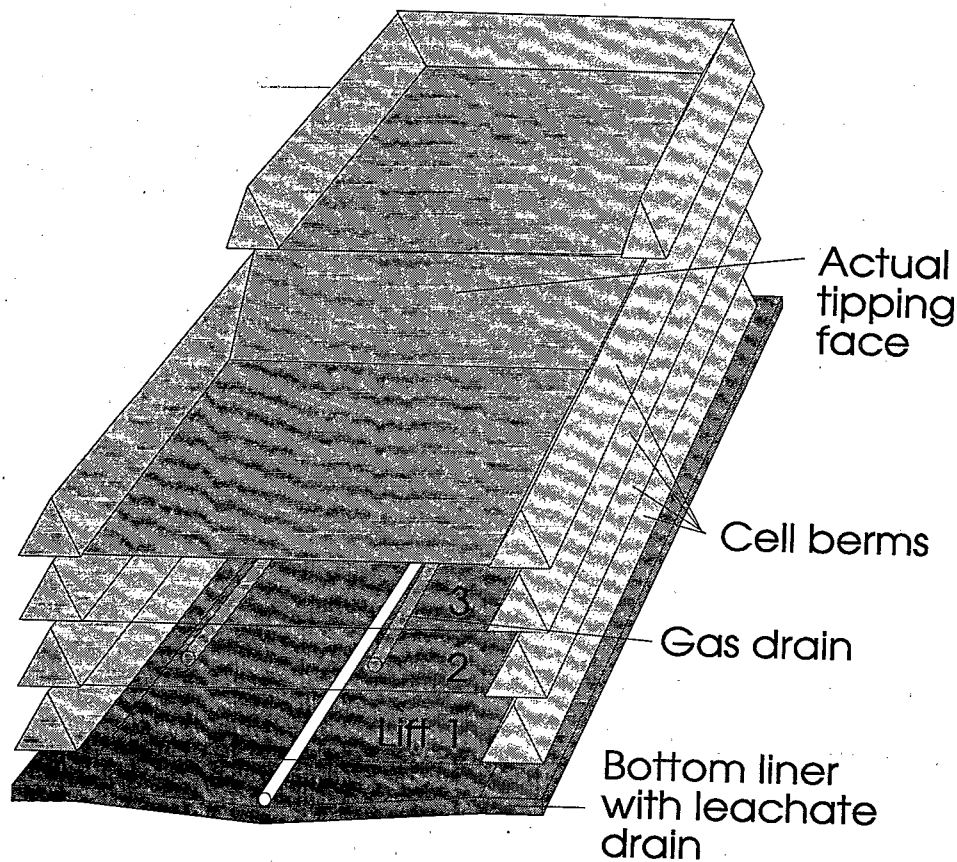

Figure 2. Construction of a waste cell.

The cell is supported by other cells surrounding it. The cell walls are built up by earth berms, which are placed on top of the previous berm after finishing one lift. The waste is then always landfilled in a closed area surrounded by earth bunds.

Every cell has a gas collection system consisting of horizontal drains in every second lift. The horizontal drains are placed 30 to 50 m apart. The horizontal drains are installed for collecting LFG during filling of the waste. After the cell has been filled, they can be complemented by vertical gas wells.

The width, length, and height of the cell depends on the amount of waste landfilled during a day and the land available for the landfill, but it ought to be a goal to have a cell filled in less than 2 years. Leachate production can then be minimized as the top cover can be brought on at an early stage. The amount of precipitation that has entered the waste is then small compared with the amount of water that can be absorbed by the waste.

Although the infiltrated water volume is small, there will be leachate production, which has to be collected and treated. The division of a landfill in cells opens the possibility to divide the incoming waste into fractions and landfill these in separate cells or cell blocks. The treatment of leachate then can be made for the separate waste categories in the landfill.

In the application for an environmental permit of the Filborna landfill and treatment facility in Helsingborg, the advantages and disadvantages of the cell technique were described as follows (very much of the experiences so far have come from the test cells at Filborna).

#### *Advantages*

When possible, the bottom cell layer can be composted before the next lift is applied. A low pH level in the waste can then be avoided, and the methane gas generation starts very early. The biochemical oxygen demand (BOD) concentration in the leachate is fairly low from the start as the volatile fatty acids are consumed and transformed to methane gas.

When working in a small, closed area, the compaction of the waste can be done efficiently. The compaction in the test cells gave a density of the landfilled household waste of 0.9 ton/m<sup>3</sup> compared with 0.6 tons/m<sup>3</sup> in the ordinary earlier operation of the landfill (1). The area of the tipping face is also kept very small to control the waste better.

Due to a very good compaction, a daily cover is not necessary. This technique was first tried in the test cells with a good result. When a daily cover is not used, volume is saved, and at the same time no nonpermeable layers are built in that can stop water and gas movement in the waste.

The boundaries of earth bunds, which always are built 2.5 m above the tipping face, prevent paper and plastics from being blown away from the cell. The exposure of the tipping face is also diminished.

#### Especially for Bioreactor Landfills

A biocell is a tight container for the waste in which organic waste is decomposed. No mixture with other wastes is necessary. In the Swedish test cells, the temperature is 20°C to 25°C

4 years after landfilling, probably because of the rapid waste filling and because the waste is better isolated due to the berms around the waste. The biogas yield per year at the Filborna test cells equals  $10 \text{ m}^3/\text{ton}$  of waste ( $0.16 \text{ ft}^3/\text{y,lb}$ ).

The gas losses to the atmosphere are much smaller than from an ordinary landfill. In the test cells, 70 to 90 percent of the gas generated on a yearly basis is collected.

### *Disadvantages*

In spite of good control at the tipping face, and precautions taken, the bird problem is very bad. In the case of Filborna, being located about 10 miles from the sea is part of the problem.

### Especially for Bioreactor Landfills

When tipping the fresh organic waste, odor can be spread to the neighborhood. Especially in the morning, it has been observed that gas arises from the active working area. The same problem occurs when gas drains are dug down in the waste.

### **Development of Future Bioreactor Landfills**

In general, it can be said that the existing test cells in the coordinated test cell program and the full-scale cell experiences are the first generation of cell constructions in Sweden. Many improvements are necessary (see Figure 3).

The test cell experiments and the full-scale cells made from the experiences of the test cells have shown the following design weaknesses at Filborna (the design of the test cells is shown in Figure 4).

Due to settlement, there have been some problems with the horizontal gas drains. The drains at the bottom of the cells have been sinking 0.6 to 1.2 m together with the leachate drains. The material under the bottom liner, consisting of old, mixed refuse from 1955 through 1960, has caused this settlement. The gas drains function if they are blown with high-pressure air every month. The gas drains at a 5-m level above the bottom have never functioned correctly because of failure of the connecting gas pipes leading to the internal gas net. Finally, the gas wells have gradually been filled with sludge and water. This has led to a new construction of the wells, which provides an opportunity to pump out the water. In the next generation of cells, other gas collection devices, such as closed trenches and wells with a larger diameter, will be used.

The tipping face will be changed completely in the next generation of cells. Instead of having the different waste trucks going out on the cell, they will unload the waste in a specially designed unloading area. The waste will be tipped down to a storage area from where a wheel-loader or a crawler tractor will carry the waste out in the cell. The next cell at Filborna is shown in Figure 5.

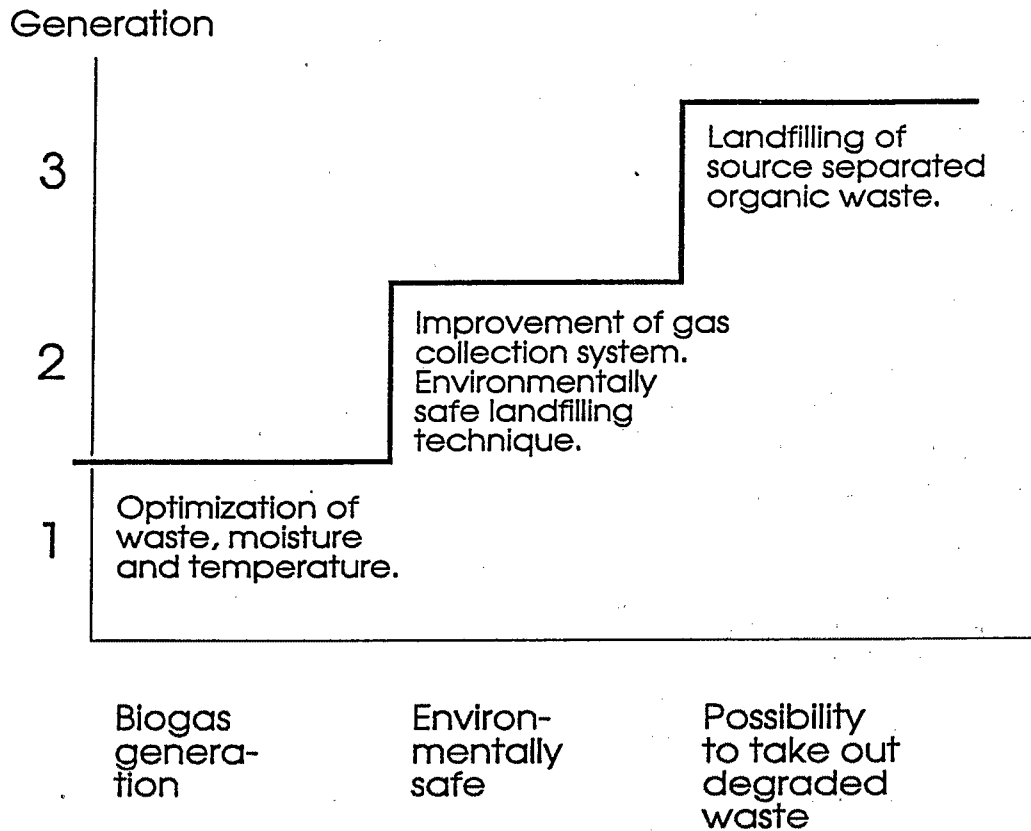

Figure 3. Different generations of cell construction and improvements made.

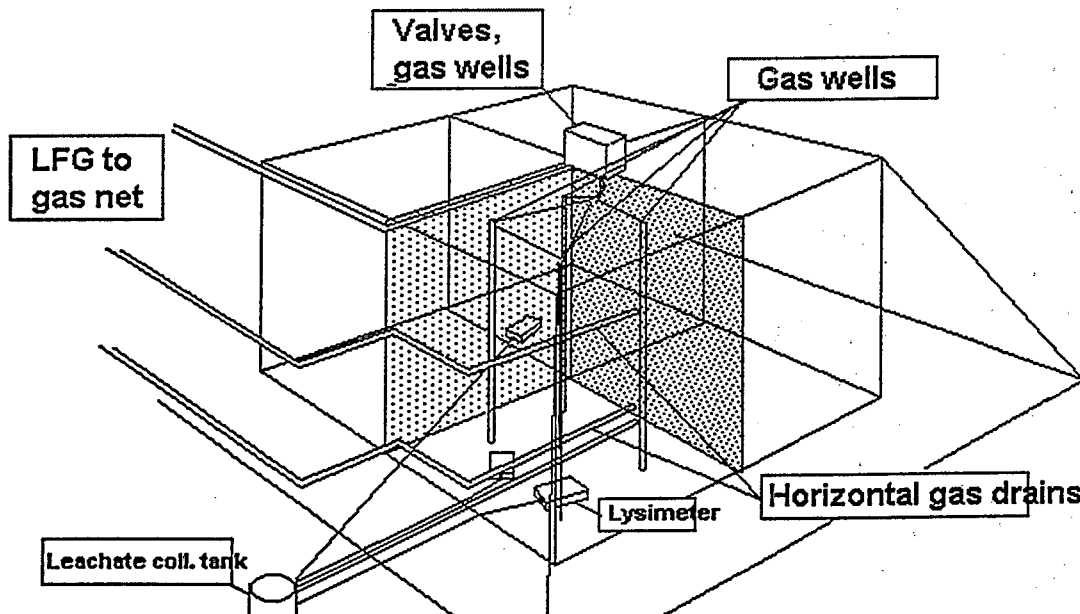
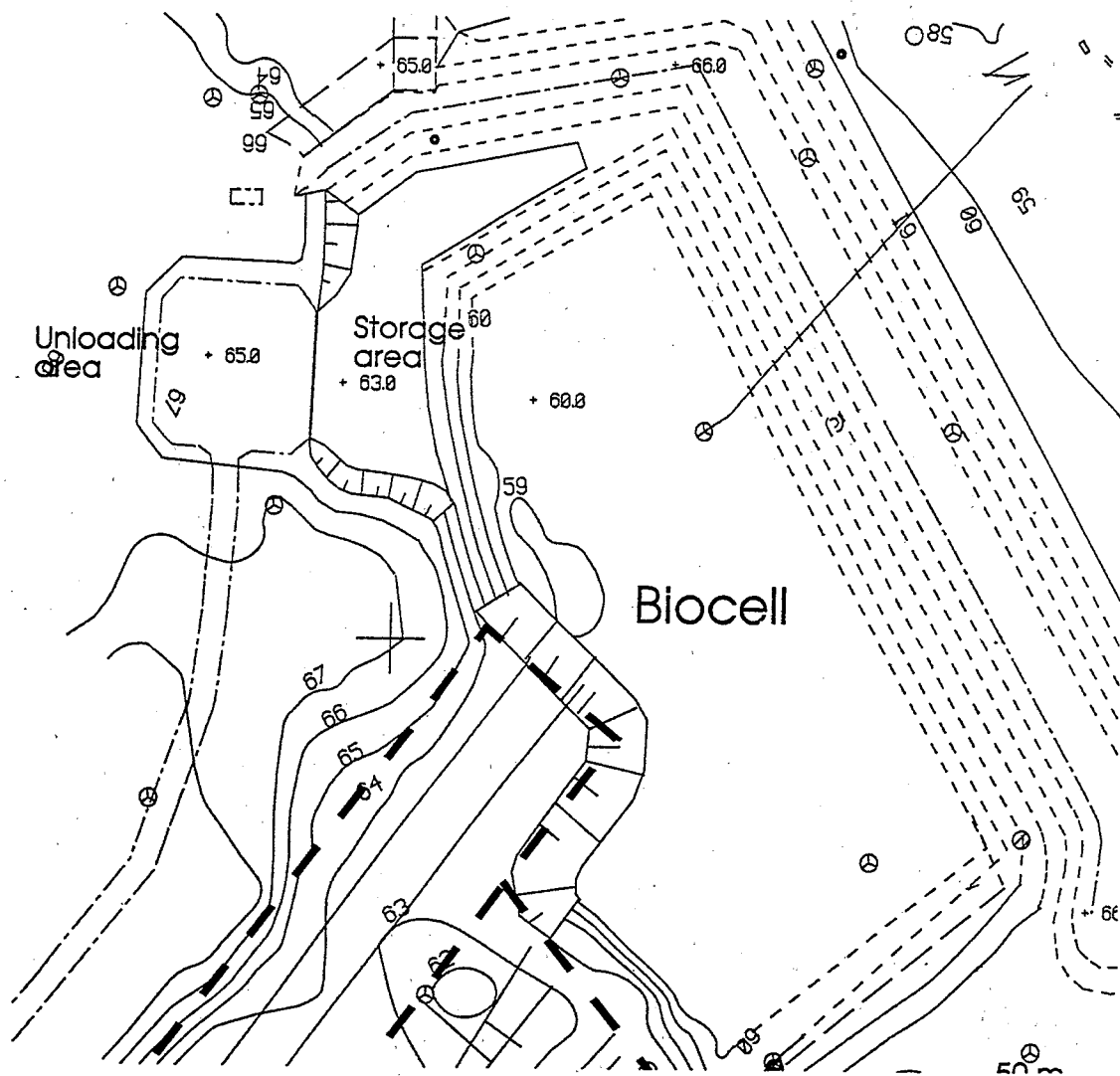

Figure 4. Design of the test cells at Filborna.



**Figure 5. The biocell with separate unloading area.**

The cell will be placed on top of an older landfill where old waste will be excavated to provide space for the cell. The old waste will be screened and the fine fraction used as cover material. The coarse fraction will be placed in the surrounding berms. The berms will be covered with earth.

One option for the third generation of landfills is to have a short, intensive degradation period, accelerated by optimized moisture content and optimal temperature. After this period, the waste is composted and screened to obtain a useful compost. This will be tested at Hagby

and Söderhall, the two waste treatment facilities outside of Stockholm. These facilities are operated and owned by SÖRAB, a community-owned waste company for the northern communities of Stockholm.

## The Spillepeng Test Cell Project

### *Introduction*

One of the projects in the cooperative test cell program is located at Spillepeng, outside Malmö. The Spillepeng site, run by the SYSAV Company, serves about 500,000 people. The landfill has a system for gas recovery that has been in operation since 1983. The SYSAV Company thus has a long tradition related to LFG and an interest in development and innovations within the field. In 1988, they reserved an area of approximately 250 x 50 m where it was possible to construct "test cells" for different studies.

### *Material and Methods*

The final number of test cells is a result of the compromise between available land, economic resources, and variables to study. The test parameter in this case is the composition of the solid waste in the different cells, and the variety as shown in Table 1.

**Table 1. Composition of Solid Waste in Test Cells**

| Cell Number | Composition of Solid Waste in Test Cells  |
|-------------|---|
| 1.          | Mixed domestic (household) and commercial (light industrial) waste. Mutual at 30/70%, respectively. |
| 2.          | As cell 1 with fatty sludge (5%).   |
| 3.          | Waste with high organic content: source-separated wet fraction, restaurant waste, horse manure.     |
| 4.          | Domestic waste.   |
| 5.          | Domestic waste with fatty sludge (5%).  |
| 6.          | Domestic waste with leachate recycling (start in May 1991).   |

All cells are as identical as possible in their construction. The volume is about 8,000 m<sup>3</sup>, and the cells contain about 4,000 metric tonnes of waste. The dimensions are 35 x 35 m (110 x 110 ft), with the surface sloping from a height of 9 m to 2 m (30 to 6 ft). The cells are all lined with clay in the bottom and in the walls. A cross section of a cell is shown in Figure 6. The bottom is also equipped with a plastic liner for safe leachate collection. The surface has a final cover of 0.5 m of clay and 0.3 m of topsoil, which is planted with grass.

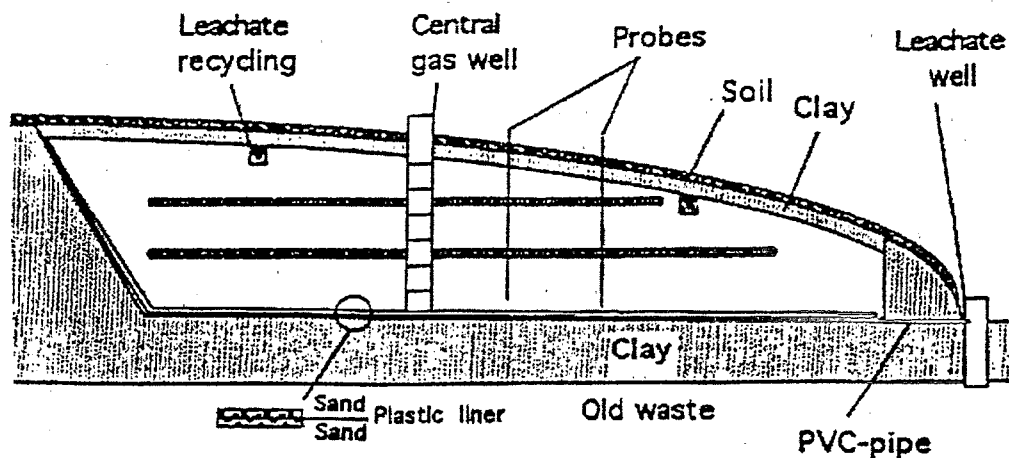

Figure 6. Test cell performance.

The gas is collected in horizontal drains on two levels. Each level is directed separately to a "test house" where gas quantity and quality are measured. The gas drains are made of used tires. These are laid in a ditch directly in the solid waste.

The leachate is collected at the lower end of the cells, where a gravel ditch has a tight connection to a leachate well of 2-m<sup>3</sup> capacity, where individual monitoring of flow and sampling is possible.

Furthermore, two special probes (wells) in each cell for studying pressure, temperature and gas quality at different depths are provided.

Field data such as flow, temperature, pH, and other simple parameters are collected every second week. Every 6 to 8 weeks, gas and leachate are sampled for a comprehensive analysis of most parameters. The solid waste is sampled once a year on the levels 2 and 4 m beneath the surface.

The gas is analyzed for CH<sub>4</sub>, CO<sub>2</sub>, C<sub>2</sub>H<sub>4</sub>, C<sub>2</sub>H<sub>6</sub>, O<sub>2</sub>, N<sub>2</sub>, and H<sub>2</sub> on a gas chromatograph with a detection level of 5 ppm. The leachate is analyzed for organic content (BOD, chemical oxygen demand [COD]), nutrients (different forms of phosphorus [P] and nitrogen [N]), volatile fatty acids (VFA), pH, conductivity, chloride, redox potential, suspended solids, dry solids, fat, and most heavy metals. The solid waste is analyzed for temperature, pH, total solids (TS), organic content, N, P, sulfur (S), VFA, and biological methane potential (BMP).

### *Results, Discussion, and Conclusions*

This project is generating considerable data, which cannot all be discussed or presented. In this paper, major results and trends that may be valuable as applied knowledge are emphasized.

## General

During the first 2 to 4 months, all cells reacted as anticipated. This means that the cells with nutrient-rich content had a more nutrient-rich leachate, and they started earlier to produce biogas. This phenomenon soon faded, and the difference is now (1995) being evaluated.

## Solid Waste

The temperature in the waste immediately rose to around 50°C due to initial aerobic conditions. But after only 12 months, the temperature decreased to 20°C to 30°C. The settlement in the cells is all moderate, with settlement of about 0.5 m, representing about 7 to 8 percent. The moisture content in the solid waste for the different cells is shown in Figure 7. The moisture content is increasing, especially from 1993.

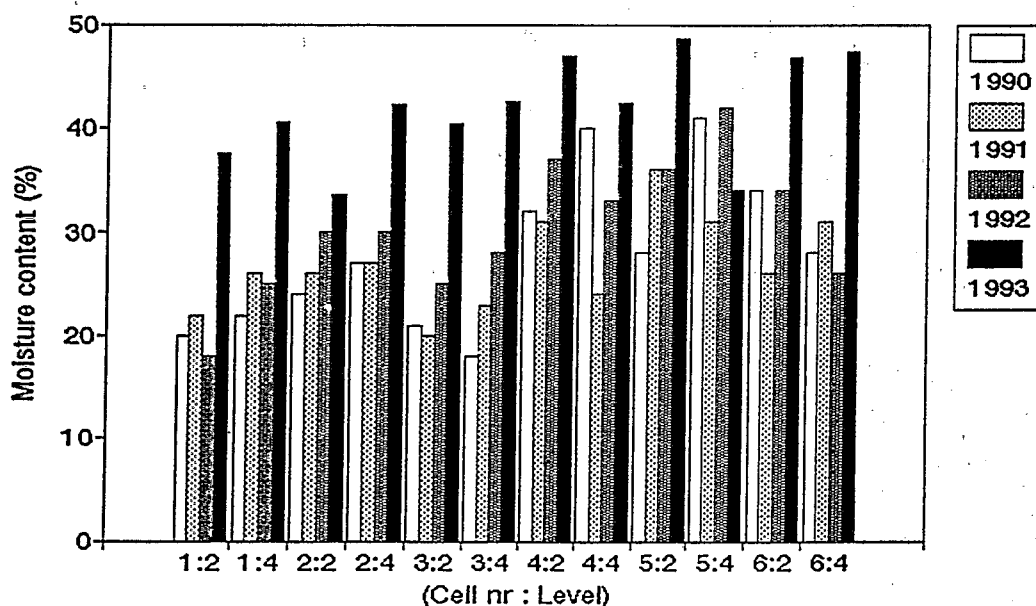

Figure 7. Moisture content in the solid waste samples.

In general, the pH has increased in the solid waste from around 6.5 - 7.0 to 7.0 - 7.8. As expected, the amount of VFA has decreased in the solid waste.

## Leachate

One of the reasons for the construction of the cells was to see how leachate production could be controlled. During the first years in operation, the leachate production was very low (less than 50 mm/y), but during the last 2 years, the production has increased (see Figure 8).



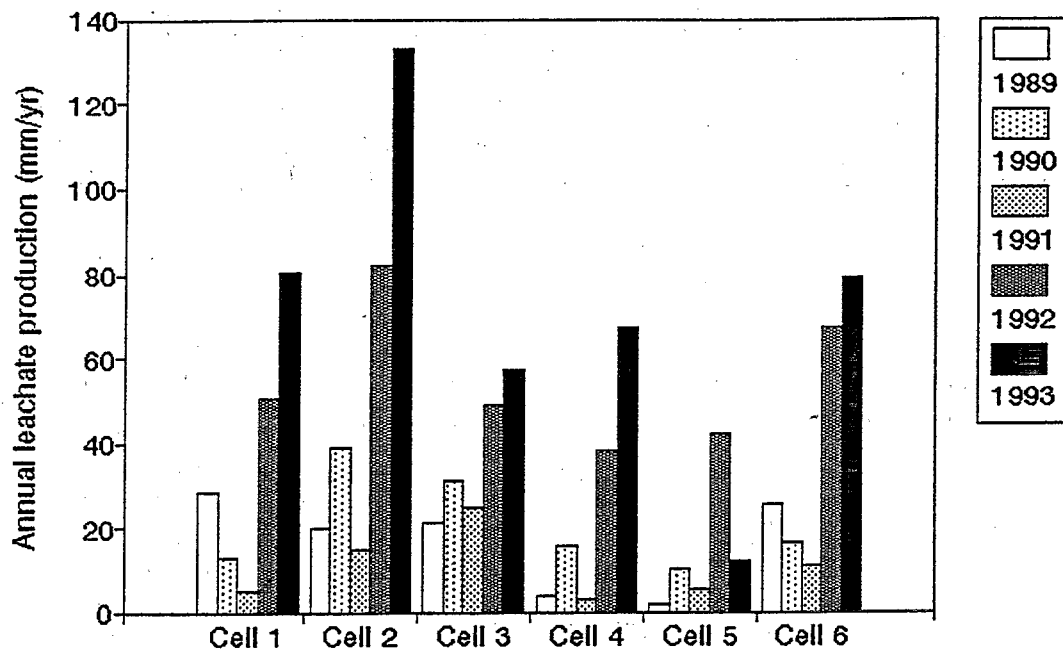

Figure 8. Leachate production (mm/yr).

The annual precipitation in the Spillepeng area is around 650 to 700 mm (26 to 28 in.). Thus, the leachate production ranges from 2 to 10 percent of the precipitation. These values are very low compared with those reported from full-scale sites. Nilsson (2-4) found an average of 287 mm/y from some 20 full-scale sites, but it is important to recognize that the bottom very often is not sealed at full-scale sites.

The quality of the leachate is represented with two graphs of the organic content. The first (see Figure 9) shows the leachate COD content, and the second (see Figure 10) shows the BOD:COD ratio. The VFA content in the leachate to a large extent exhibits the same pattern as COD.

The nutrients are, as expected, high, with a high nitrogen mainly as ammonia (400 to 800 mg/L). The phosphorus content is in the range of 4 to 8 ppm for all cells. The chloride content has been rather constant around 1,000 to 2,000 mg/L. The metals are all in very low concentrations, and many, such as mercury, lead, and cadmium, were around the detection level.

The methane production has been high throughout the whole period. Just 6 months into operation, the methane content of the biogas was as high as 40 to 45 percent. The content of CH<sub>4</sub> in the biogas now is rather steady around 60 percent. The annual methane production per ton of dry matter, estimation of losses due to diffuse emissions at decreased extraction, and the assumption that all oxygen loss is due to methane oxidation are shown in Figure 11.

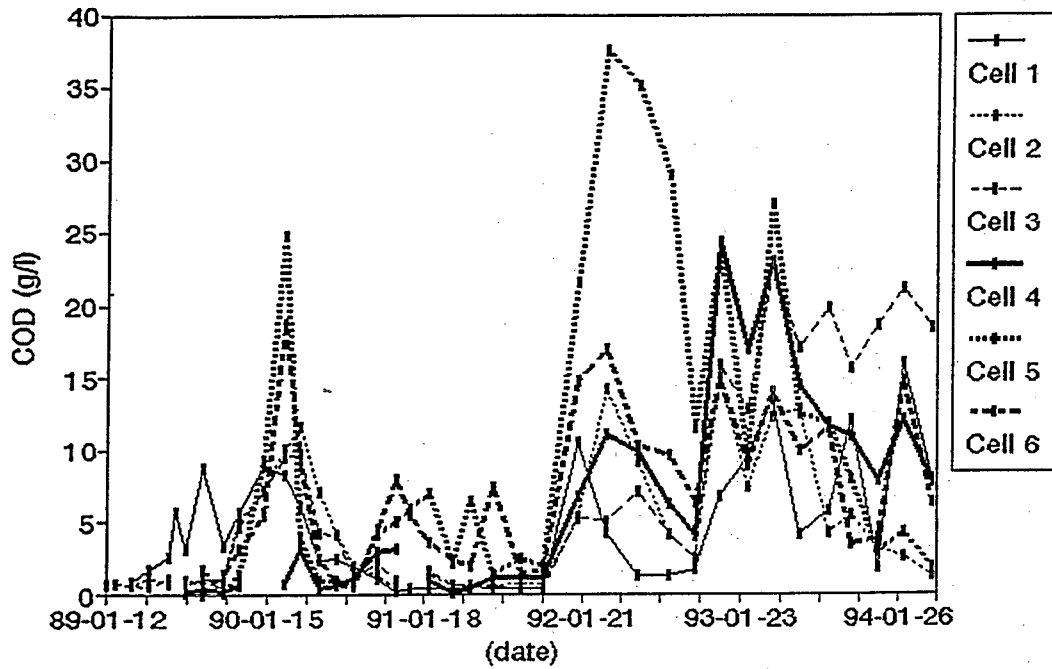

Figure 9. COD content in leachate.

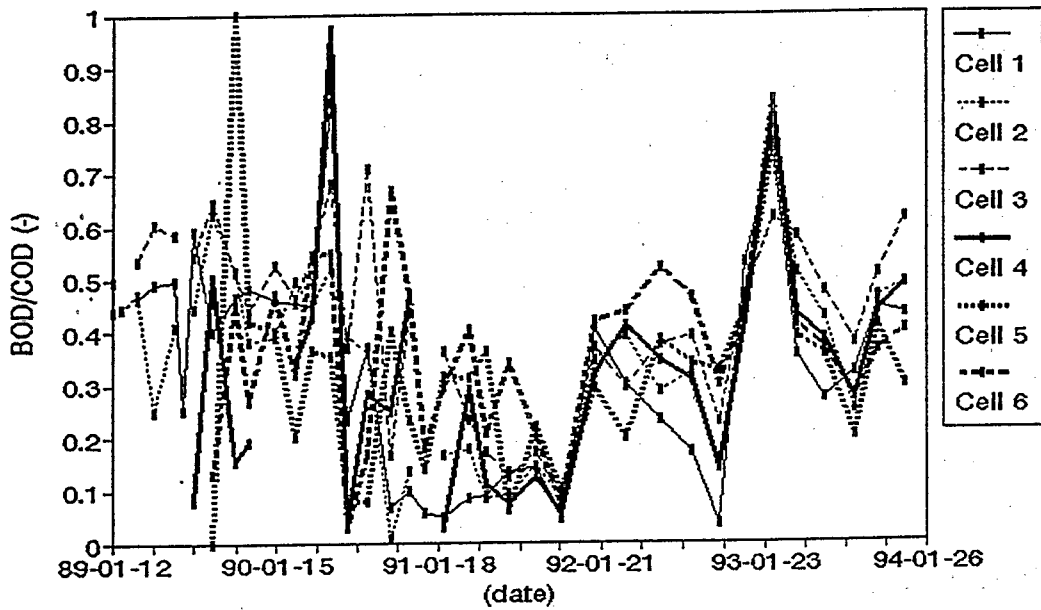

Figure 10. BOD:COD ratio in leachate.

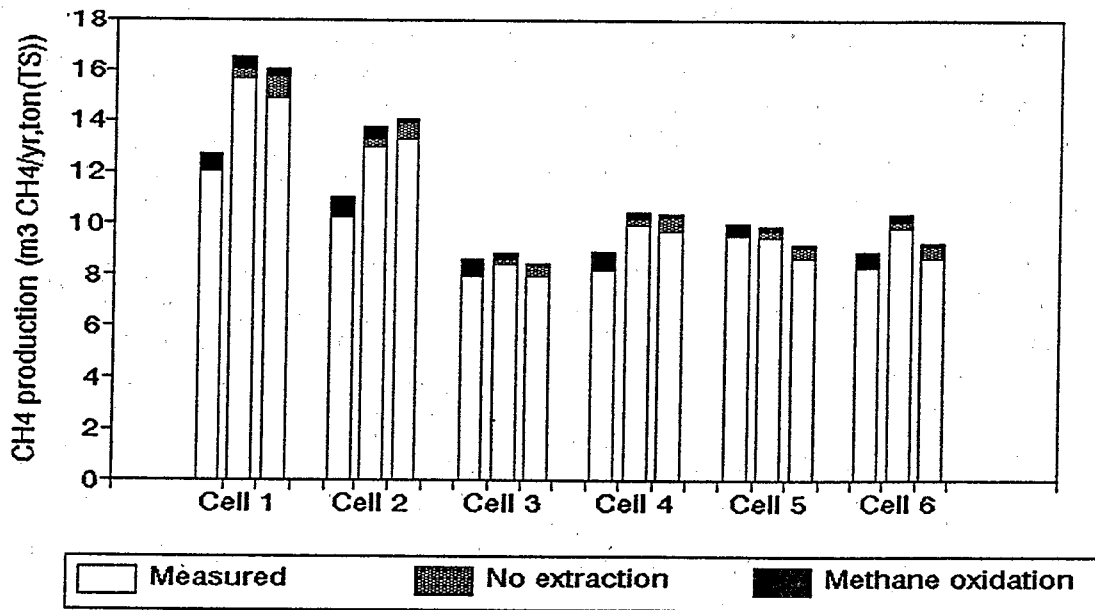

Figure 11. Annual methane production and estimation of losses. The three bars for each cell represent the production during the years 1991, 1992, and 1993.

### Biogas

The extracted amount of methane gas exceeded that reported from full-scale sites. Normally, the design value for a full-scale site is around 5 m<sup>3</sup> of biogas per ton of wet solid waste and year. When using these units, the cells will produce between 6 to 11 m<sup>3</sup>/ton/yr.

### *Summary and Discussion*

The most striking fact is that cells 1 and 2 (with mixed waste) produced the largest amount of methane gas. The very nutrient-rich, wet cell (No. 3), thought to be the most active, produced the smallest amount.

During 1993, the highest annual leachate production was registered. It was, on average, 72 mm/yr, or 11 percent of the annual precipitation. Since the winter of 1991/1992, leachate production has been clearly dependent on the seasons.

Up to fall 1991, leachate quality clearly indicated a stable methane phase had been achieved. The pH values were, in fact, generally rising above 7.5, while BOD:COD ratios were below 0.1. During 1992, radically different leachate qualities were registered, which now and then indicated acid phase conditions with pH values less than 7.0. The organic content increased strikingly in correspondence with increased flow during the winters of 1991/1992 and 1992/1993.

The phosphate content also showed similar "washout phenomena" and increased in the cells from below 5 mg/L to maximum values between 10 and 20 mg/L each. The trends for nitrogen, roughly 90 percent as ammonium, showed more tendency to concentrate and increased strongly for the summer of 1993 to maximum values for ammonium from 600 to 1,800 mg/L for the different cells. Even the trends for chloride indicated washout, but the values were still generally similar to the earlier ones (i.e., between 1,000 and 3,000 mg/L).

Although relatively high biogas generation was recorded, the leachate and solid samples are indicating that stable methanogenic conditions do not exist. Perhaps it is not so contradictory because this phenomenon has been reported by others (5), where about 80 percent of the total methane gas production took place before a stable methanogenic situation was present. For the test cells, this gives a calculated time of 3 to 7 more years before a stable methanogenic situation may occur.

The relatively high amount of gas extracted indicates not only that discrete cells are a good solution for anaerobic decomposition of solid waste but also that used tires may be used as excellent drain systems.

#### References

1. Meijer, J.-E. 1992. Design of cells for landfill gas generation. Proceedings of the ISWA 6th International Solid Wastes Congress and Exhibition, Madrid, Spain.
2. Nilsson, P., K. Hasselgren, and J. Pettersson. 1991. Treatment of leachate: Evaluations of methods for treatment of leachate from sanitary landfills. Bulletin Serie VA nr 65, lund oktober 1991 (in Swedish).
3. Nilsson, P., T. Bramryd, S. Edner, and S. Thuresson. 1991. Biogas from waste: Optimization of biogas recovery by controlled deposition of solid waste. Lägesrapport I. Bulletin Serie VA nr 60, lund mars 1991 (in Swedish).
4. Nilsson, P., and S. Edner. 1991. Test cell study of methane production by controlled waste deposition. Proceedings, vol. 1, of SARDINIA 91, Third International Landfill Symposium, CISA. pp. 149-159.
5. Ehrig, H.-J. 1987. Anaerobic degradation of municipal solid waste: Laboratory-scale tests. In: Wise, D.L., editor. Global bioconversions, vol. II. Boca Raton, FL: CRC Press. pp. 121-152.

#### Additional Reading

Meijer, J.-E., and T. Bramryd. 1994. Landfill cells for biogas generation. International Directory of Solid Waste 1994/5, The ISWA Yearbook. London, UK. pp. 130-131.

Meijer, J.-E., T. Bramryd, B.-L. Persson, and T. Welander. 1994. The Filbornagas project. Status Report 2. NSR, Filborna, RVF Rapport 1994:8 (in Swedish).

- Meijer, J.-E., T. Bramryd, B.-L. Persson, and T. Welander. 1993. The Filbornagas project. Status Report 1. NSR, Filborna, RVF Rapport 1993:11 (in Swedish).
- Nilsson, P. 1993. Optimizing biogas recovery by controlled deposition of solid waste. International directory of solid waste management 1993/94. The ISWA Yearbook, ISWA, London, UK. pp. 50-57.
- Nilsson, P., M. Åkesson, and T. Bramryd. 1994. Biogas from waste: Optimization of biogas recovery by controlled deposition of solid waste. Lägesrapport IV. RVF Rapport 1994:7, Malmö, Sweden (in Swedish).
- Nilsson, P., M. Åkesson, and T. Bramryd. 1993. Biogas from waste: Optimization of biogas recovery by controlled deposition of solid waste. Lägesrapport III. RVF Rapport 1993:13, Malmö, Sweden (in Swedish).
- Nilsson, P., T. Bramryd, S. Edner, and M. Åkesson. 1992. Biogas from waste: Optimization of biogas recovery by controlled deposition of solid waste. Bulletin Serie VA nr 65, lund juni 1992 (in Swedish).
- Persson, B.-L. 1993. Tests of gas collection systems. NSR, Filborna, RVF Rapport 1993:12 (in Swedish).
- Persson, B.-L., and M. Wörnö. 1992. Study of different types of gas extraction devices for recovery of landfill gas. Proceedings of the ISWA 6th International Solid Wastes Congress and Exhibition, Madrid, Spain.



## Leachate Management in Landfill Bioreactor Design and Operation

---

W. Lamar Miller and Timothy G. Townsend

Department of Environmental Engineering Sciences, University of Florida, Gainesville, Florida

---

The Alachua County Southwest Landfill (ACSWL) is a 27-acre landfill with a state-of-the-art composite liner and leachate collection systems. It has been operated as a wet cell bioreactor since 1990 and has recirculated approximately two-thirds of the leachate collected using a variety of recirculation systems. Evaluations of leachate quantity, leachate quality, settlement rates, gas production, and cone penetrometer results have been or are being performed at the site (1). This paper focuses on leachate management by recirculation of the collected raw leachate to the landfill.

Figure 1 is a schematic of the ACSWL, the site of the University of Florida leachate recycle experiments. There are three cells on this site, two that are closed and capped, with ongoing active gas recovery. There is also an active 27-acre fully lined (composite lined) landfill, and the figure indicates the location of the first recirculation experiment at ACSWL. In 1990, at the beginning of leachate recirculation at this site, pond number one was constructed and operated in the area indicated (see Figure 1). After a period of leachate recycle of approximately 9 months, this pond was filled with municipal solid waste (MSW) and is now an active part of the landfill. The areas around it were the locations of ponds 2, 3, and 4, which were filled in late 1994 and early 1995, and are no longer in use. The performance of the infiltration pond leachate recycle system (LRS) has been previously reviewed (2). The flow that results from those ponds to the leachate recovery system is discussed later.

A second method of leachate recycle, a horizontal injection LRS, was installed to allow pressure injection of any volume of leachate that is desired to recirculate into the landfill. Figure 1 presents an approximate location of those horizontal injection lines (HIL). There are now HILs installed, and they are progressively added, one after the other, as lifts are completed. The location of the HILs within the landfill are more easily visualized on Figure 2, which indicates a typical cross-section of the lines. Each HIL was installed at the completion of a lift of solid waste in the landfill before a subsequent lift was placed above each line. They were excavated 3 ft deep and 3 ft wide. Shredded tires were placed in the bottom of the trench, and a perforated pipe was laid on top of the shredded tires. Standard schedule 40 polyvinyl chloride (PVC) pipe with drilled holes was underlain by 1 ft of shredded tires and covered with approximately 2 ft of shredded tires, then the deposit of waste continued. The result is three lifts coming up from the bottom. The lowest pipe is approximately 15 ft from the landfill liner with the second and third lines at 10- to 12-ft intervals above that. Sixteen HILs have been installed for recirculation of leachate, and 12 have been used extensively.

A common practice in landfill research is to attempt to describe leachate and stormwater flow by a numerical model. Figure 3 represents a timeframe before recirculation of leachate was begun at this site. The Hydrologic Evaluation of Landfill Performance (HELP) (3, 4) model

---

was used in an attempt to predict the leachate that would be obtained at this landfill cell and then compared with the actual measured volume of leachate that was obtained. The results do not always agree, but they are relatively close. The actual volume of leachate measured is usually within 20 percent of the model predicted flow. A comparison on a cumulative basis over a period of 2 to 3 years indicates a difference of approximately 20 to 25 percent in the volume that we actually obtain versus the predicted volume. Approximately 25 percent more leachate has been recirculated than was predicted would be generated using the standard HELP model and assuming a field capacity of about 0.3. Figure 4 is a cumulative plot of the same data. Figure 5 presents the results of an alternative model using data obtained in this study (5). The results are no better with our model than with the HELP model. Figure 6 is the cumulative version of those same data. It appears that plus or minus 25 percent is about as close as can be obtained to projected leachate flows. Figure 7 is a model that is a regression analysis of leachate flow data used to predict future flow by the current

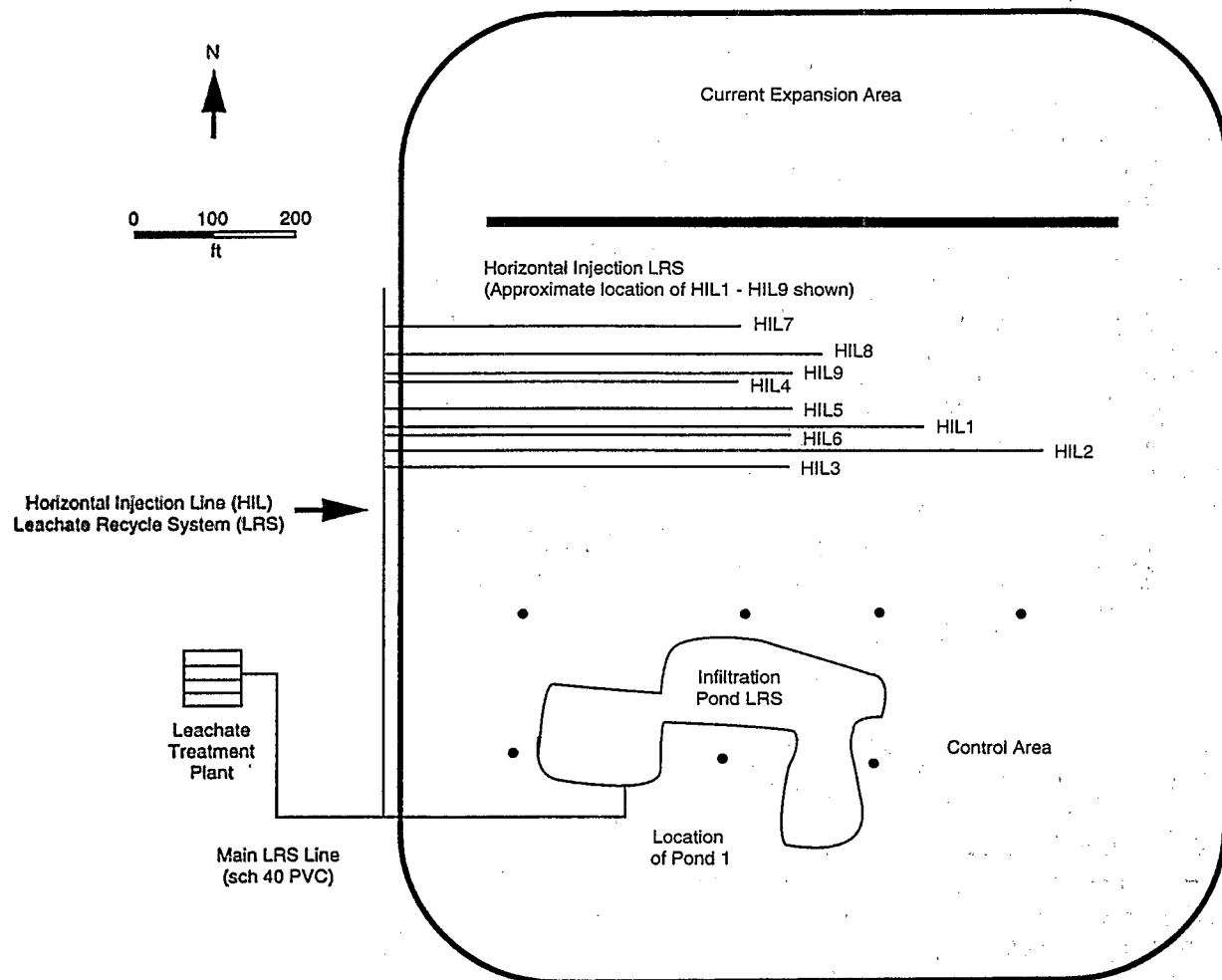
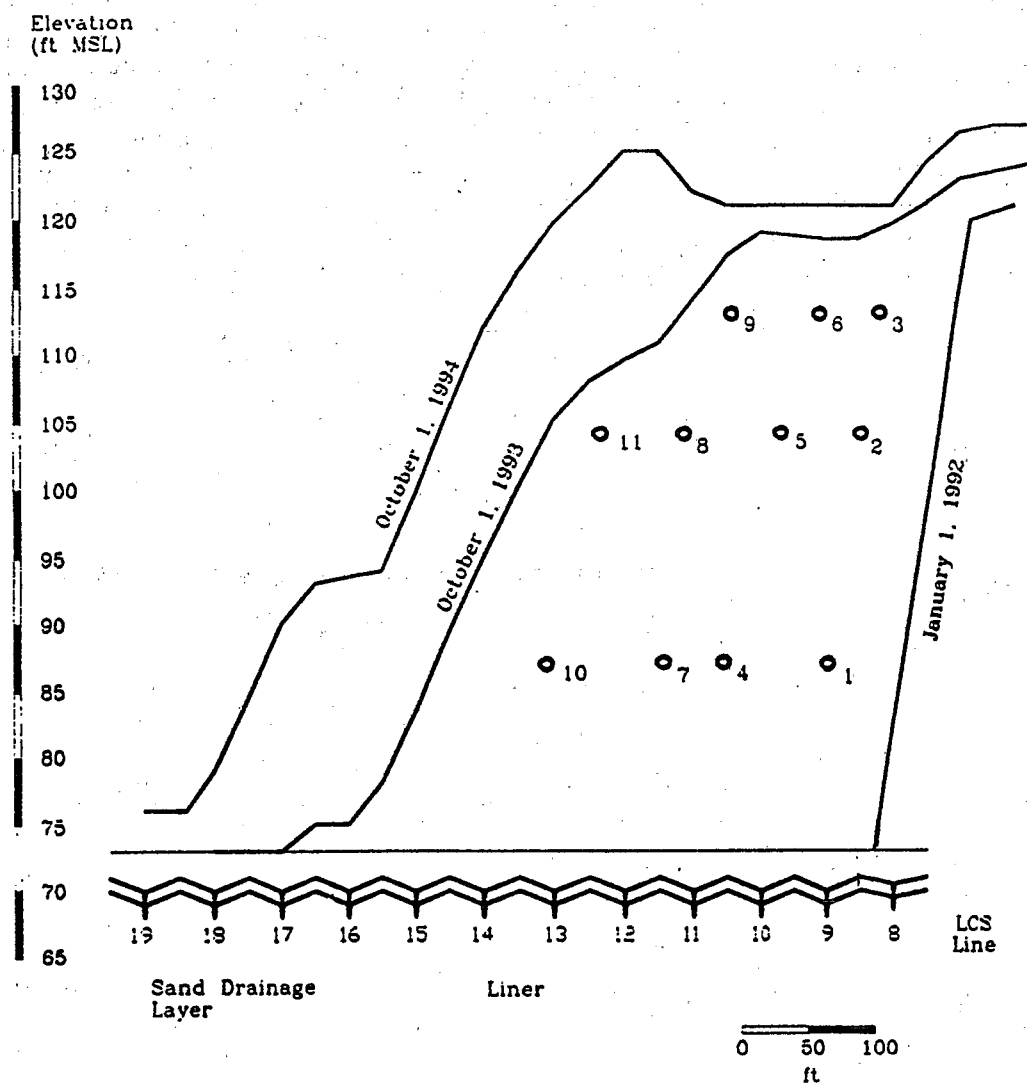

Figure 1. ACSWL leachate recycle systems.





**Figure 2. Cross-section of injection lines.**

superintendent of operations at the site. Rain events that occur at the site have a large effect on flow results. Every time a rain event over 1 in. occurs, the leachate volume surges up dramatically, followed by a slow return to the baseline flow. The projected baseline flow from the simple regression model is approximately 20,000 gal/day for this particular landfill with its history of leachate recirculation. This applies to approximately 20 acres of filled area or approximately 1,000 gal/acre/day of leachate return as a result of leachate recycle at this site.

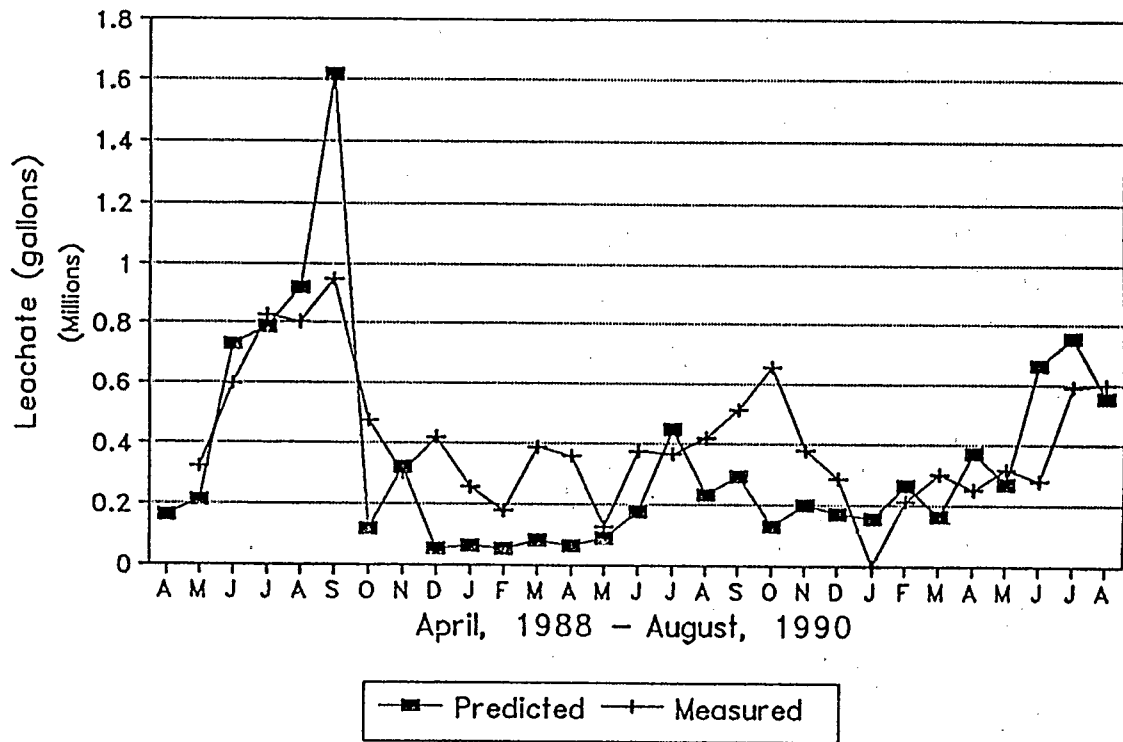

Figure 3. Predicted versus measured leachate production for a field capacity of 0.2942 vol/vol.

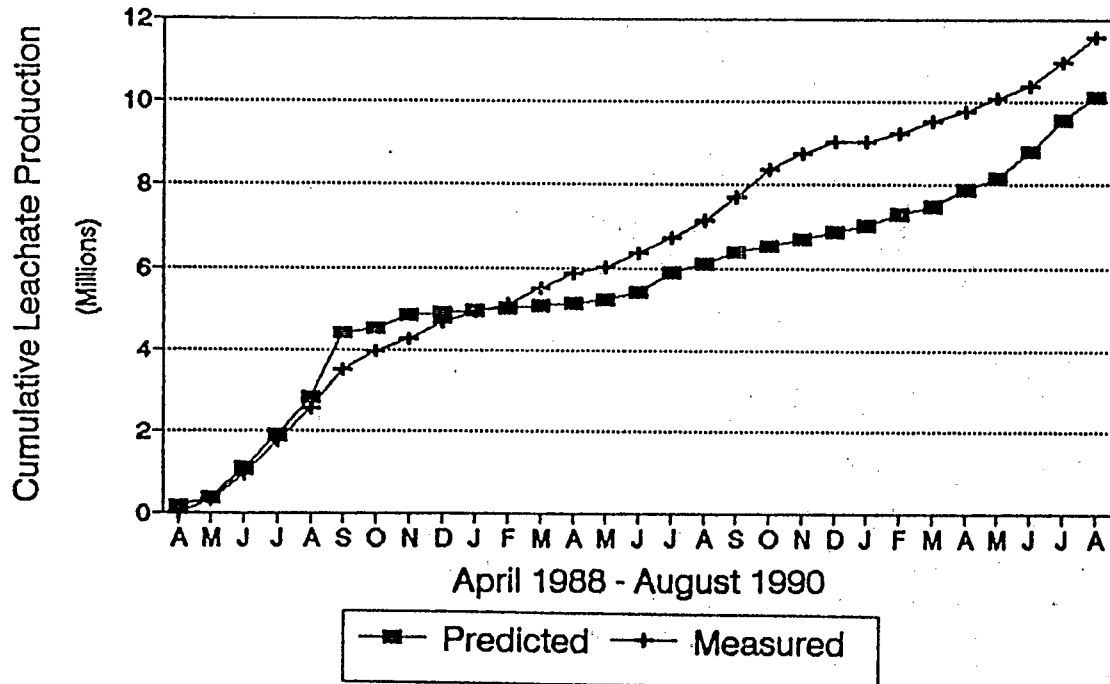
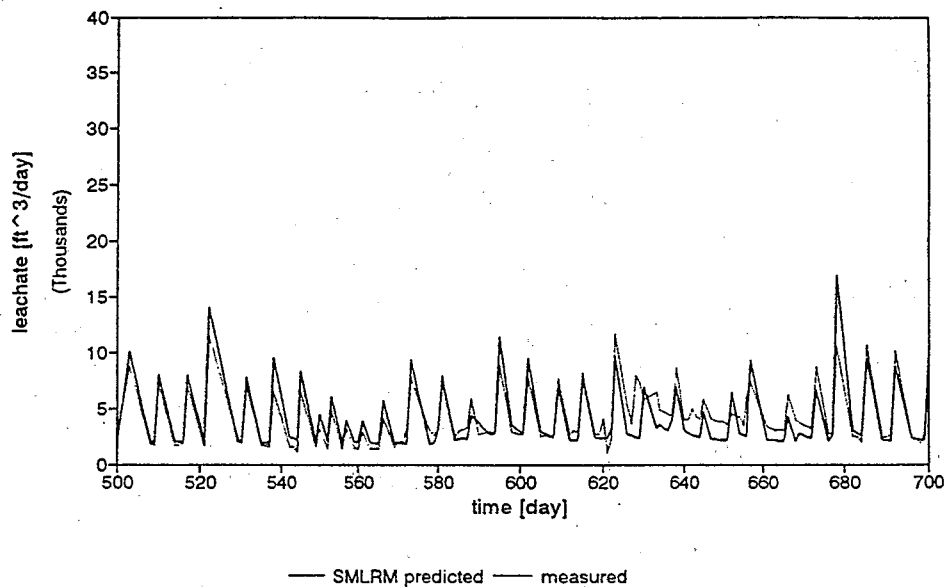
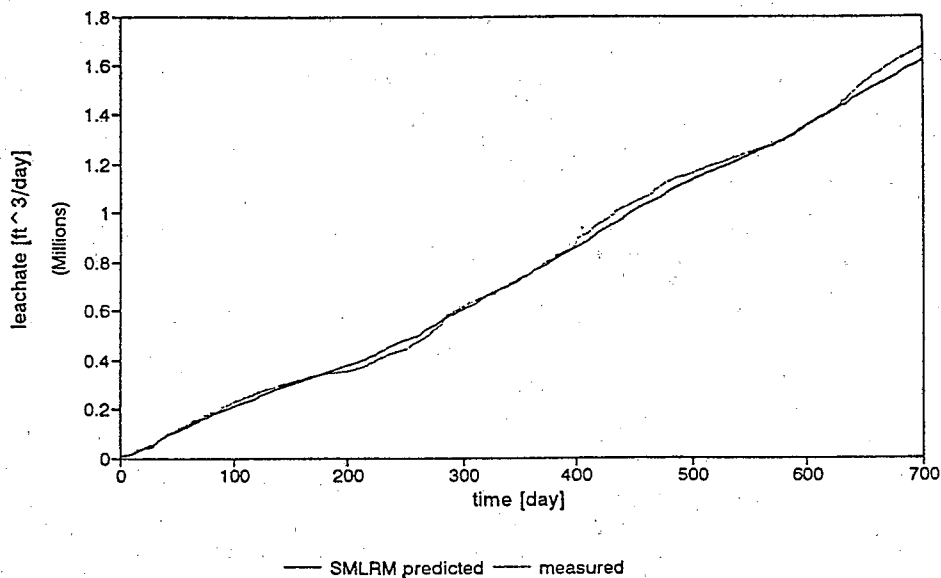

Figure 4. Cumulative predicted and measured leachate production for a field capacity of 0.2942 vol/vol.



**Figure 5. SMLRM predicted incremental flow versus ACSWL data.**



**Figure 6. SMLRM predicted cumulative flow versus ACSWL data.**

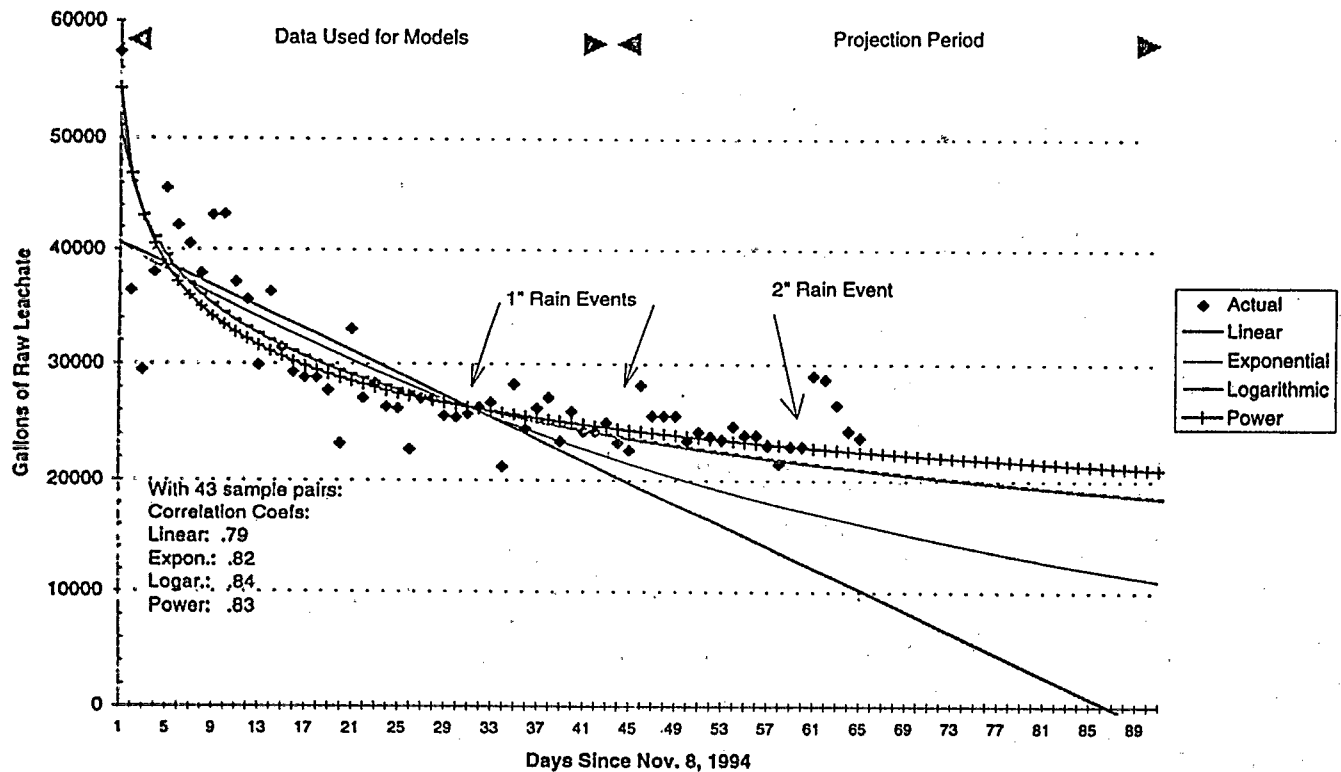

Figure 7. Modeled leachate flows.

Figure 7 indicates the effect of rainfall on the return leachate flow. Figure 8 presents a record of the rainfall at this site over a 6-year period. North Central Florida receives a large number of heavy rainfall events including at least one 6-in. storm every year in late July or August. Heavy storm events at this landfill result in substantial increases in leachate flow primarily as a result of contribution of stormwater runoff to the normal leachate flow. This requires close coordination with the operators at the site because the leachate storage volume is frequently insufficient to store the leachate volumes obtained following heavy (over 1 in.) rain events. The 180,000 gallons of storage capacity at the leachate treatment plant can be augmented by heavy injection during high production periods and results in some equalization of the return flow. At ACSWL, injection laterals and ponds were used to provide equalization during heavy flow periods. This equalization allows the treatment plant to operate within its one shift capacity and saves the substantial cost of adding trucks on an irregular basis to haul excess leachate for disposal. Large loadings of leachate recycle systems should be cautioned, however, because large volumes do have an effect on the system. When the ACSWL ponds were drained and filled in, a tremendous volume of water remained, which had to be removed from the site. Heavy loadings of the HIL LRS is discussed in an upcoming section. The use of a leachate recycle system for flow equalization must be coupled with a landfill management approach of minimizing the volume of stormwater at the site that must be managed as leachate.

Proper design of landfills requires that stormwater management receive as much attention as does leachate management in heavy rainfall areas such as Florida. Figure 9 displays the raw

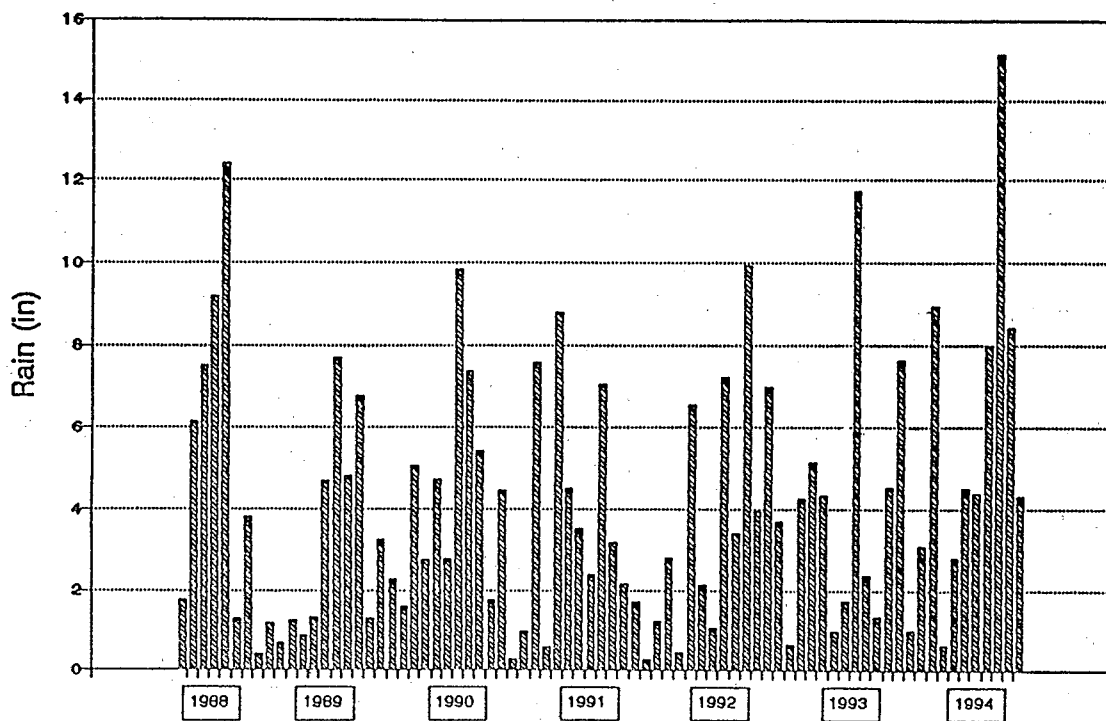

Figure 8. Monthly rainfall at ACSWL (May 1988 through September 1994).

leachate volume changes as a function of time in a generally upward trend at this site. The leachate flow was about 300,000 gal/month in the early years of the study and is now up to a current average above 600,000 gal/month in the same cell. This primarily results from the very high flow rates (over 1 million gallons) that resulted from the heavy rainfalls in the spring of 1994. At that same time, because of severe washout and erosion problems, the landfill lost its ability to segregate stormwater flow from leachate flow and now handles all of the flow as contaminated leachate in the system. The landfill no longer has separate systems to manage the flows. Now, the system requires pretreatment of all flow that is not recirculated into the landfill. Since recirculation of leachate first started in 1990, Figure 10 indicates that approximately 400,000 gal/month have been recirculated. The raw leachate flow during the same time has been about 500,000 to 600,000 gal/month of leachate. It is estimated that the recirculation volume on average for the life of this fill has been about two-thirds of the raw leachate that has been collected while using about one-third of the landfill volume. Some months are higher, some months are much lower, depending primarily on how or what experiments are being performed at the landfill. This is not really an operational result but more a research result in terms of the specific experiment that is being run at a particular time. The results indicate that in a landfill such as ACSWL, approximately two-thirds of the total raw leachate volume can be managed by recirculation over a prolonged period of time at a typical cell. This amounts to a very large estimated cost savings over the cost to hold, treat, and truck 12 miles to a wastewater treatment plant.

Figure 11 shows that the volume of leachate treated and hauled for disposal during that same period has been about 300,000 gal/month. The ratio of treated volume to recirculated

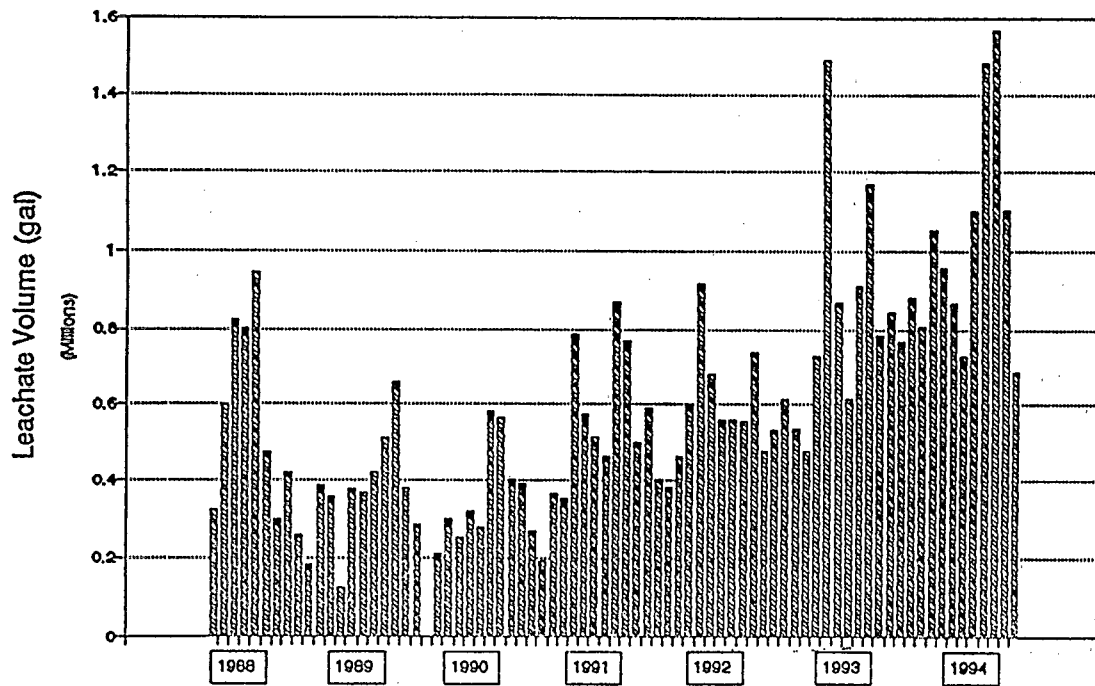

Figure 9. Monthly raw leachate volume (May 1988 through September 1994).

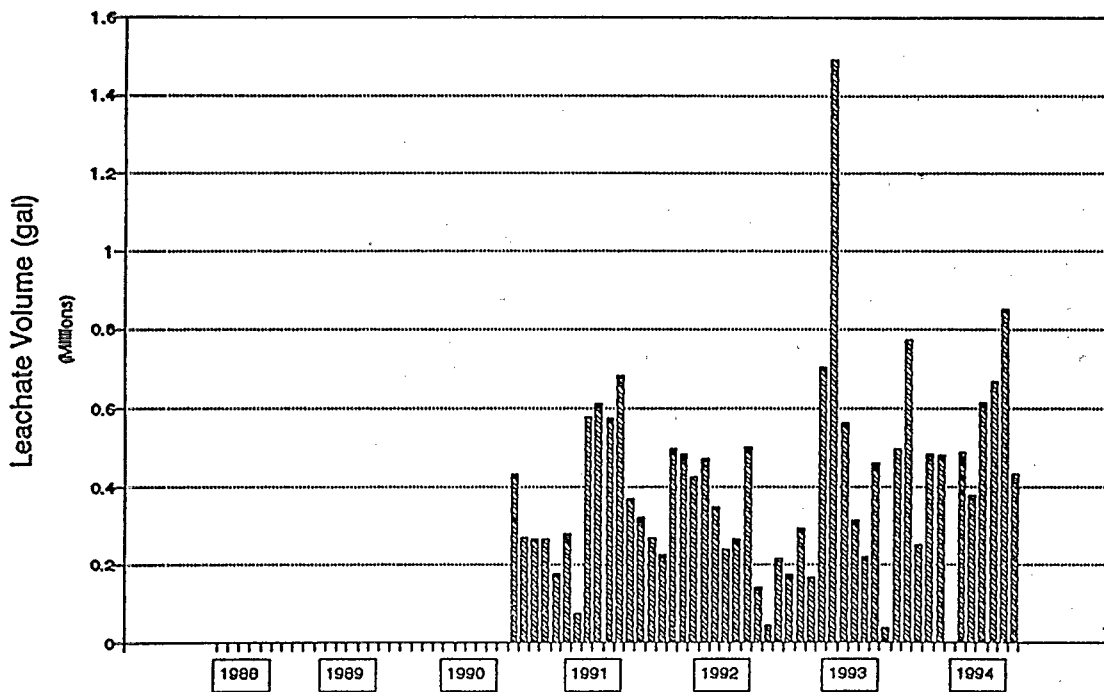

Figure 10. Monthly recycled leachate volume (May 1988 through September 1994).

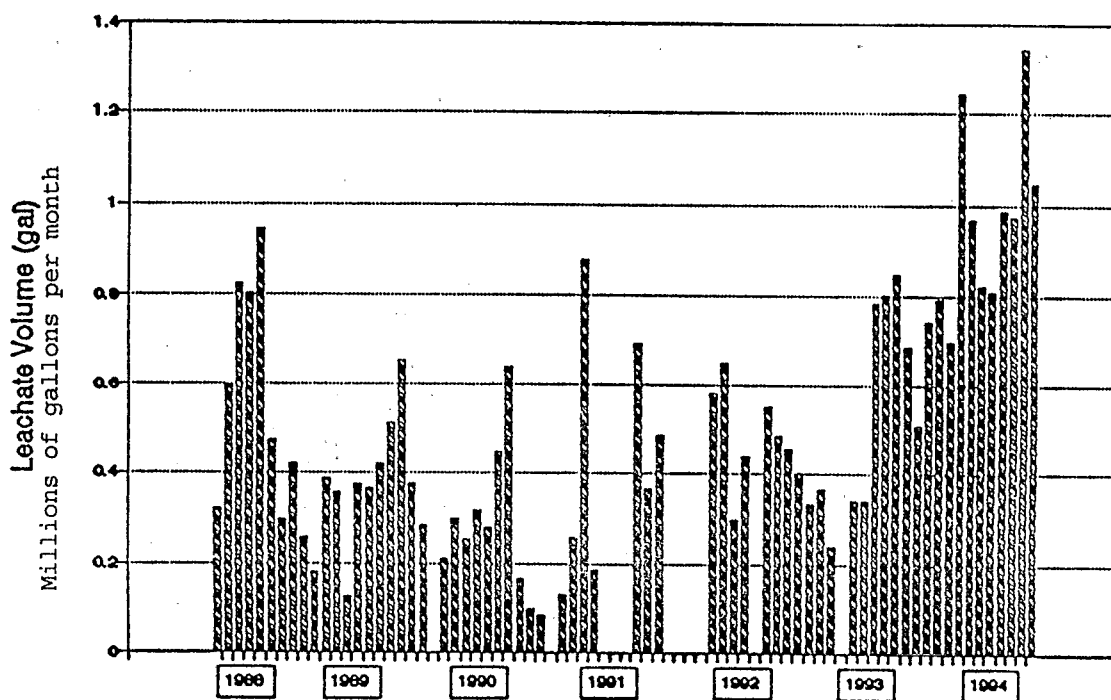

Figure 11. Monthly treated leachate volume (May 1988 through September 1994).

volume went down following the storm problems in the summer of 1994 but is expected to return to about two-thirds recirculation in 1995.

The method of leachate and stormwater management at a bioreactor landfill, or any landfill, invariably affects both the quality and quantity of the leachate. One interesting feature of the leachate recirculation observed at ACSWL (see Figure 12) is that very early on, the pH varied quite a bit from values around 7 all the way up to nearly 8 at various times. Then, after about 1 year of recirculation, corresponding to the beginning of the first return of leachate from the stored leachate in the ponds to the collection system, the pH dropped down to about 6.6 to 6.7 for quite a while. In 1993, it returned to about pH 7 and has remained fairly stable ever since leachate return began. The pH of the raw leachate indicates a very healthy landfill operation at the current time. Previous studies have observed that separate periods of hydrolysis and production of volatile acids occur during the biostabilization of waste in a landfill (6). High periods of production of volatile acids (see Figure 12) were observed at ACSWL, and the landfill is now in a range where the acids are being actively treated and methanogenesis is controlling the leachate pH for the entire site. This supports the data from the literature by the previous workers in laboratory-scale studies (6-8). Keep in mind that ACSWL is an active daily operation with fresh waste deposited every day, differing from a lysimeter study, where waste is deposited into the system in 1 day. Not only is leachate recirculation managing the volume of leachate but the quality of the leachate and the biostabilization of the waste as well.

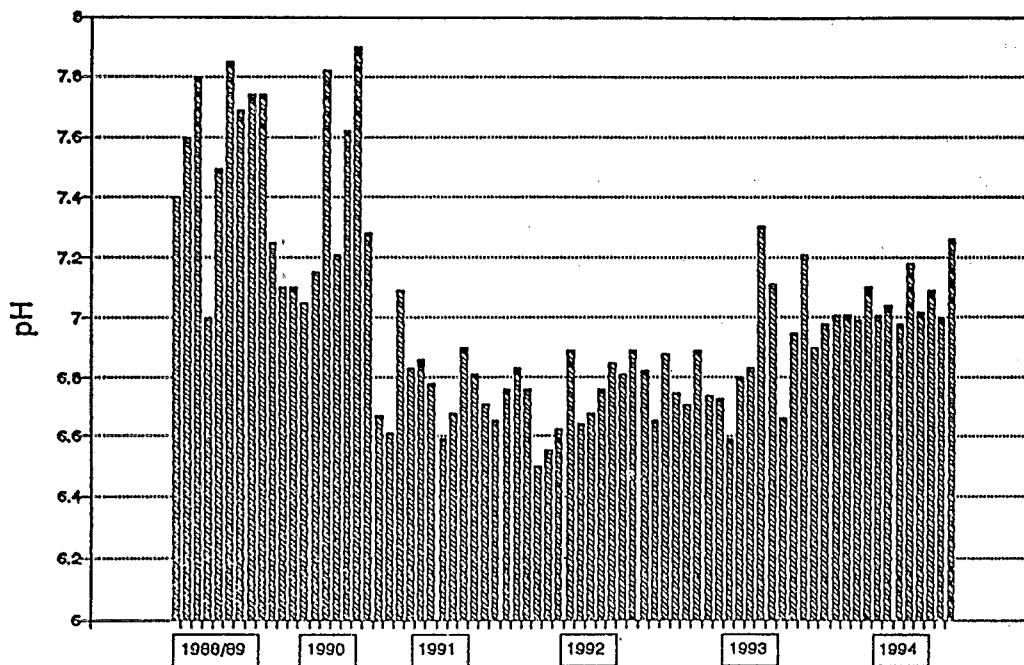

Figure 12. ACSWL raw leachate pH (November 1988 through September 1994).

A very slow but steady increase of total dissolved solids (see Figure 13) from a low of about 1,000 ppm up to a current value of about 3,000 ppm of dissolved solids was observed. The constantly increasing concentration of ammonia (Figure 14) in the raw leachate indicates a more thorough decomposition of waste with the released nitrogen from the waste being conserved in the leachate. The concentration of ammonia should ultimately peak and begin to diminish as a function of time indicating maturation of the landfill (6).

Figure 15 tracks the biochemical oxygen demand (BOD) at this particular site. The most dramatic feature of these data is the large spike of BOD concentration in 1993, resulting from heavy injection into HIL 1 during the beginning of leachate injection. BOD values quickly recovered after this event to much lower concentrations. The BOD concentration is now maintained at less than 500 ppm most of the time. The high peak resulted from an original mechanical test of the volume of leachate that can be injected into one of the HILs and HIL 1 was deliberately pumped to failure in order to determine what happens in the first test of the injection lines. The return of that leachate to the leachate collection system resulted in a considerable amount of organic and inorganic material being flushed out. The BOD spike and a corresponding chemical oxygen demand (COD) spike (see Figure 16), as well as a dissolved solids spike (see Figure 13) were observed. These concentrations all quickly returned to normal. The BOD of the leachate at this particular site is much weaker than normally reported for BOD values in landfill leachate. This indicates the treatment of organic matter in the leachate as it is recirculated to the landfill. The large spike of the COD values has restabilized at an average of about 1,000 ppm, again a low value. The higher values of



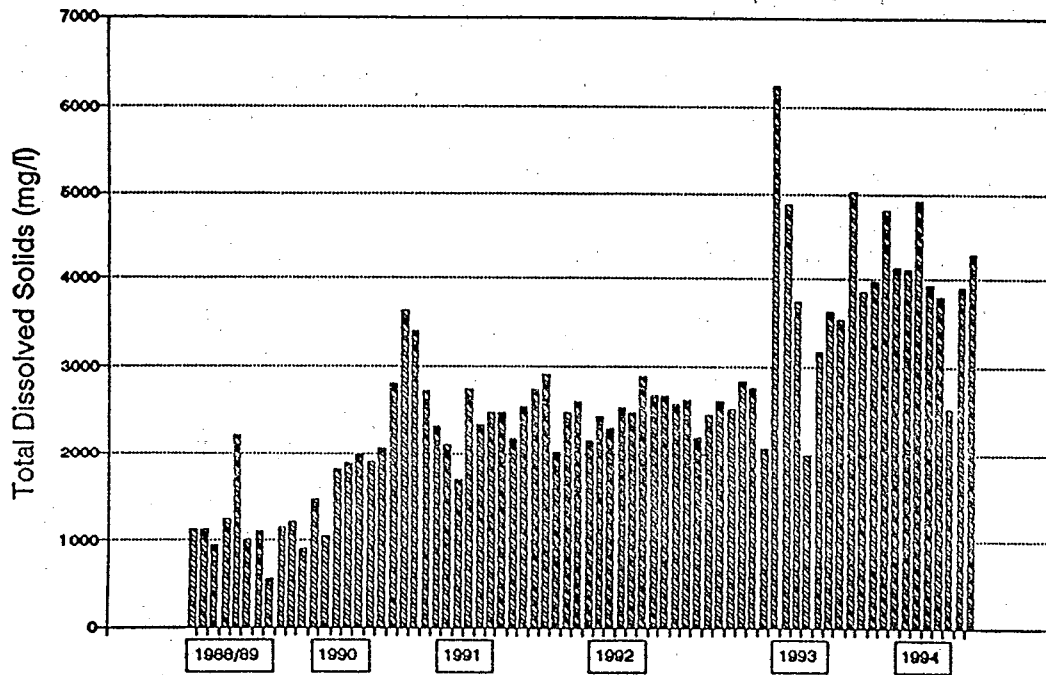

Figure 13. ACSWL raw leachate TDS (November 1988 through September 1994).

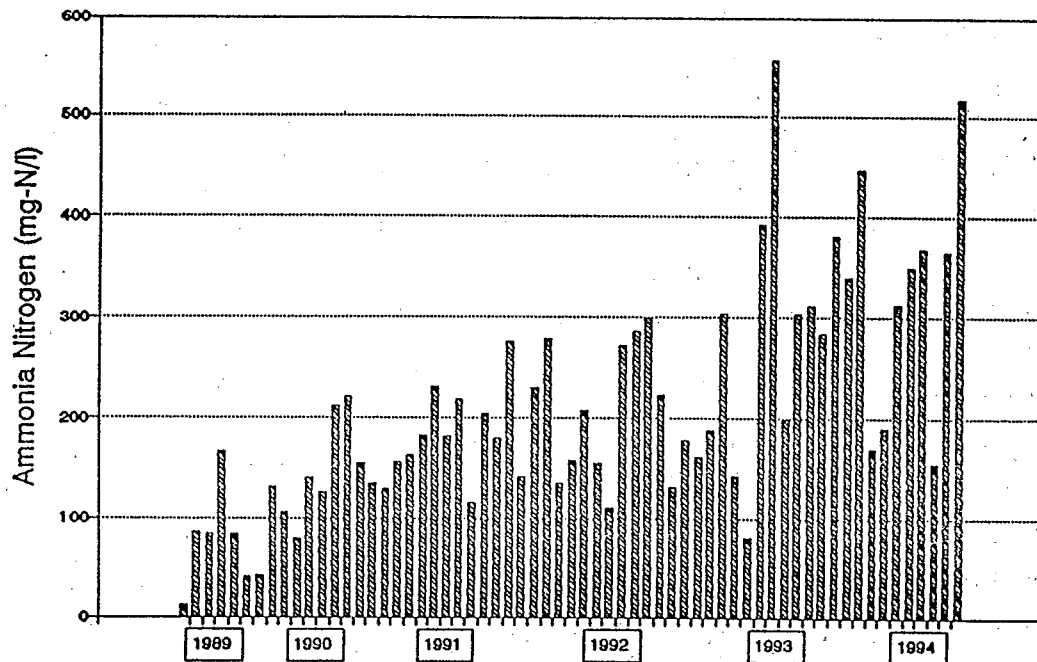

Figure 14. ACSWL raw leachate ammonia (February 1989 through September 1994).

about 2,000 ppm represent periods of return flow from successive injections during the last year of operation.

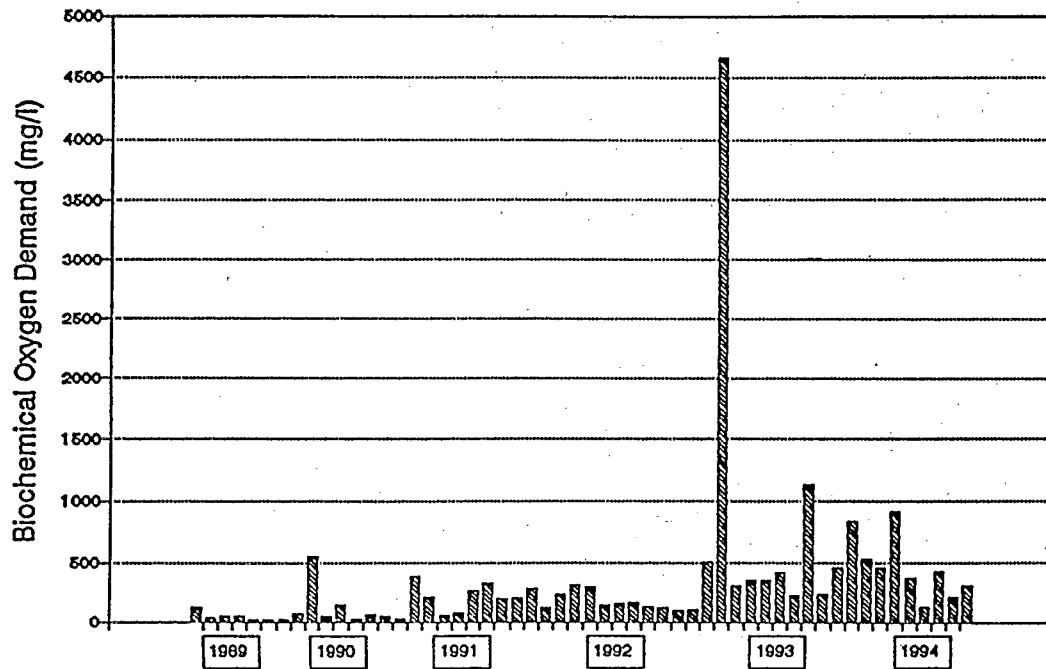

Figure 15. ACSWL raw leachate BOD (February 1989 through September 1994).

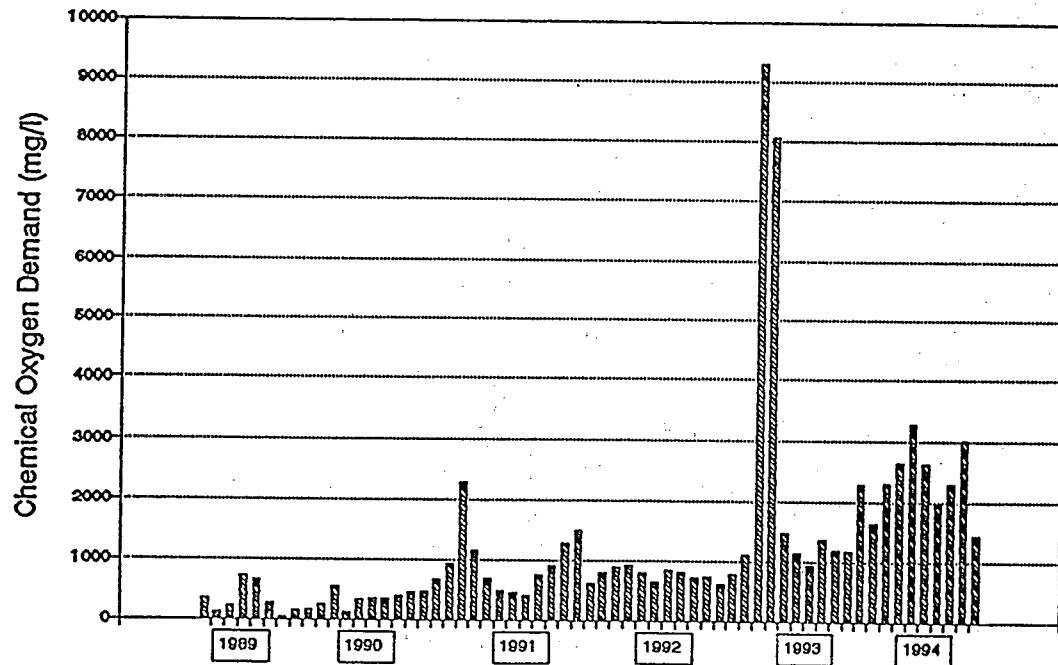

Figure 16. ACSWL raw leachate COD (February 1989 through September 1994).

Figure 17 shows that the volume of leachate recirculated by injection over time has been quite high during times that the injection system was operated. The very high return rates reflect either return from HIL 1 that was pumped to failure or a large rainfall event. Over 1 million gallons were injected into HIL 1 during March 1994, and the return appeared in early May. Additional leachate was pumped into the same line over an extended period. Additional pumping tests into other injection lines have corresponding return times to the leachate system. Figure 17 is a plot of the leachate return flow. As larger quantities of leachate were injected into the injection lines, larger quantities of leachate were returned to the collection system. When injection was stopped, however, the return volume of leachate decreased rapidly.

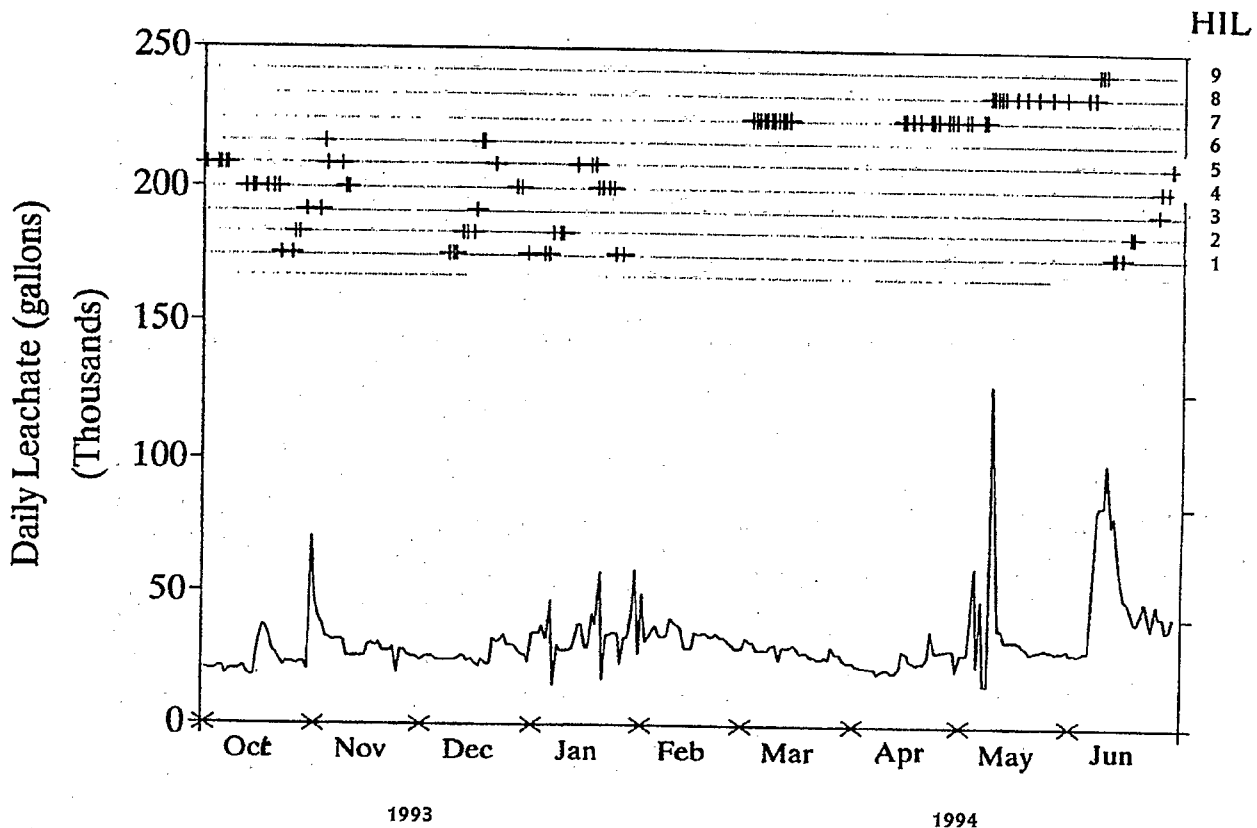
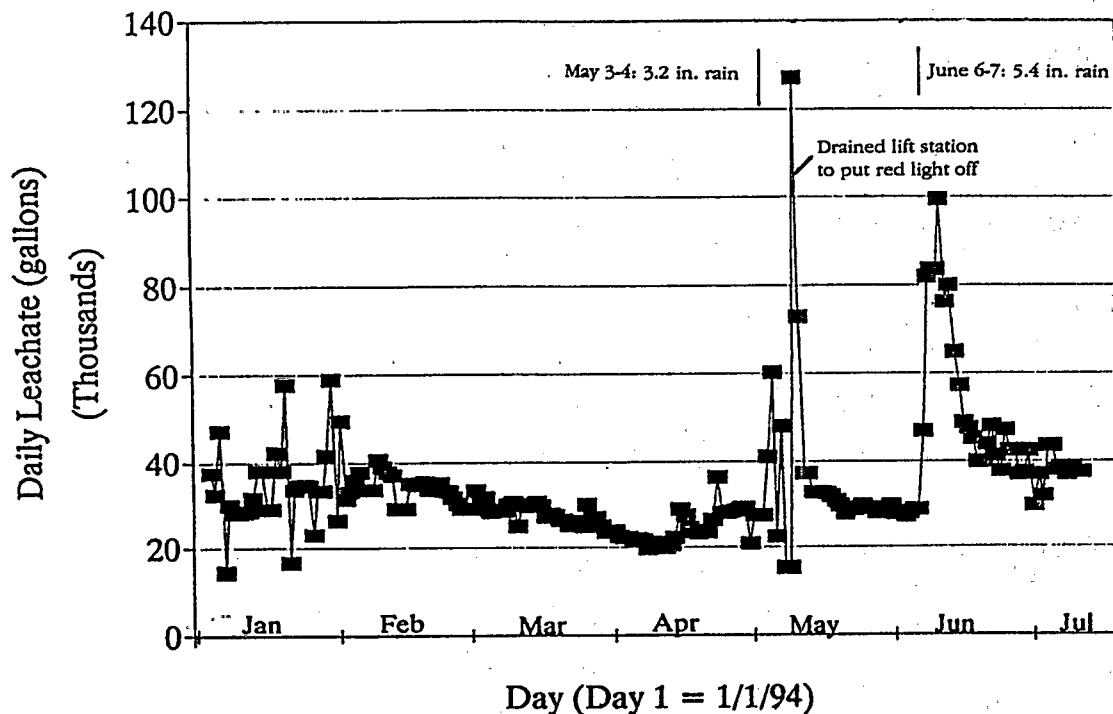

Figure 17. Leachate generation— injection schedule.

Figure 17 presents a plot of leachate return during the most recent year and indicates the volume and times of leachate recirculation by injection. The return flow does have an increased volume of flow at return times which correspond to the injection periods. After injection, there is a delay and then a high return rate. Some of these spikes in flow also correspond to rainfall events that occurred during that same period. The return flow increased during the last year as a result of injection into lines 1 through 9. This resulted in a relatively constant return volume, which results from the stored leachate in the ponds on the top of the landfill. The ponds appear to contribute about 12,000 to 15,000 gal/day of return

leachate as a baseline flow to the leachate collection system and an additional 15,000 to 20,000 gal/day is returned from the injection line system depending upon the injection history (see Figure 18).

One interesting observation is the relationship of leachate recirculation and the concentration of volatile fatty acids (VFA) in the returned leachate. The raw leachate is routinely monitored for the concentration of VFA (see Figure 19). During 7 months of operation, no leachate was injected into the landfill because of the recovery efforts from the heavy stormwater volume. During this period, the ponds were filled with waste, and they no longer functioned to add to leachate flow. Prior to that time, the concentration of VFA had consistently been in the range of 500 to 1,500 ppm with an average of approximately 1,000 ppm. During the period of



landfill. Those samples have been analyzed for residual volatile solids and biochemical methane potential, and the data for decomposition rates as a function of time indicate substantial differences in control areas and recirculation areas. The average half-life for biological decomposition of the degradable fraction solid waste in the landfill under the pond area has been decreased to less than 2 years with a projected time to stabilization of a landfill with full recirculation certainly less than 4 years. These results appear to confirm measurements reported earlier by Pohland (7) and Ham (9, 10) on laboratory measurements. The data indicate that the rate of biostabilization under the ponds with constant passage of leachate is much higher than in the injected area where leachate is added, and then allowed to stand in a semiquiescent condition.

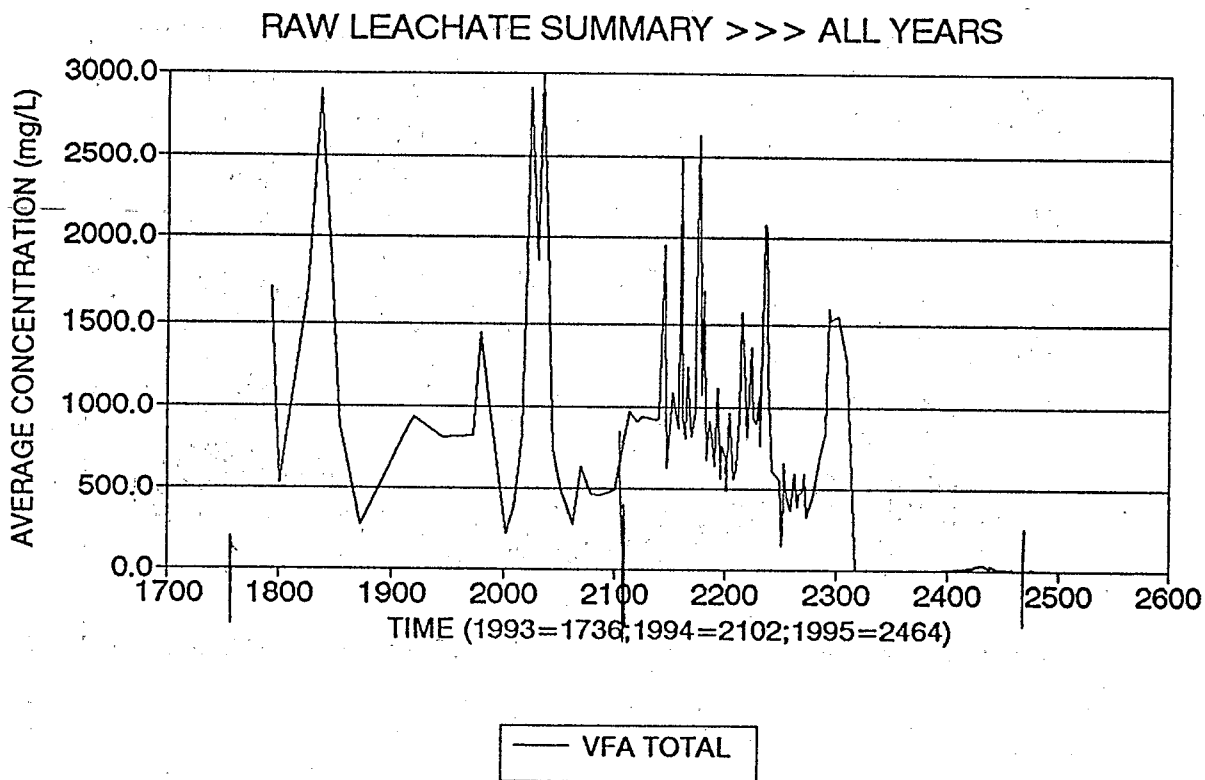

**Figure 19. Volatile fatty acids by GC/FID.**

The system has been operated to manage the flow of leachate with a much smaller storage volume than would normally be needed on a comparable site. This was accomplished primarily by using ponds on top of the landfill in which we were able to store from 1 to 5 million gallons of leachate at any given time. That's not necessarily a preferred means of recirculation of leachate, but it certainly offers some advantages that other means of recirculation do not. Major advantages include the increased rates of stabilization and having the ponds as a temporary storage for large return flows in a system with inadequate

stormwater control. One of the current focuses of the ACSWL research is directed toward determination of the operational system, which will allow the injection system to function more like the pond system for leachate circulation. This entails more frequent periods of injection into the injection lines and construction of larger infiltration galleries.

This work is ongoing at the present time. The work has been supported by the U.S. Environmental Protection Agency (EPA), the Florida Center for Solid and Hazardous Waste Management, and Alachua County. A large number of graduate students including Mark Triplett, Charles Bartlett, Hyung Jib Lee, Peggy Olson, James Nelms, Mike Ryan, Randy Sillan, and Anne Lerner contributed to the work effort in these studies.

## References

1. Miller, W.L., J.F.K. Earle, and D. Reinhart. 1994. Leachate recycle and the augmentation of biological decomposition at municipal solid waste landfills. Annual report to Florida Center for Solid and Hazardous Waste Management (June 1).
2. Townsend, T.G., W.L. Miller, H. Lee, and J.F.K. Earle. 1995. Leachate recycle infiltration ponds. *J. Environ. Eng. ASCE* 121(6):465-471.
3. Bartlett, C. 1991. Application of the HELP Version 2 model to an open municipal solid waste landfill. M.E. thesis. University of Florida.
4. Schroeder, P.R. 1989. User's guide for HELP Version 2. USAE Waterways Experiment Station, Vicksburg, MS.
5. Hatfield, K., and W.L. Miller. 1994. Hydrologic management models for operating sanitary landfills. Final report to Florida Center for Solid and Hazardous Waste Management (November 30).
6. Pohland, F.G. 1979. Leachate recycle as a management option. *J. Environ. Eng. ASCE* 106(6):1,057-1,069.
7. U.S. EPA. 1975. Sanitary landfill stabilization and leachate treatment. EPA/600/2-75/043. Cincinnati, OH.
8. Leckie, J.O., J.G. Pacey, and C. Halvadakis. 1979. Landfill management using moisture control. *J. Environ. Eng. ASCE* 105(2):337-355.
9. Hartz, K.E., and R.K. Ham. 1983. Moisture level and movement effects on methane production rates in landfill samples. *Waste Man. Res.* 1:139-145.
10. Bookter, T.J., and R.K. Ham. 1982. Stabilization of solid waste in landfills. *J. Environ. Eng. ASCE* 108(6):1,089-1,100.

## **Incorporating Bioreactor Techniques Into Daily Operation of a Landfill**

---

Richard P. Watson  
Delaware Solid Waste Authority, Dover, Delaware

---

The concept of operating a landfill as a bioreactor has been studied and tested for over 20 years. Several laboratory and pilot-scale projects have been conducted and papers published, but unfortunately, few full-scale landfill bioreactor projects have been implemented or documented. Operating a landfill as a bioreactor under the current Subtitle D and state environmental regulatory requirements is difficult but possible in Delaware. Not all states are as flexible, though. The benefits of operating a landfill as a bioreactor include the acceleration and control of the biodegradation process and the increased density of the waste.

The Delaware Solid Waste Authority has operated landfills since October 1980. Leachate recirculation and bioreactor operating techniques have been designed, constructed, and implemented since that time. Optimizing the operation of a full-scale landfill as a bioreactor requires balancing the practicality and expense with the benefits to be derived.

The design, construction, and operation of a bioreactor can be more easily optimized on a smaller scale. It is far easier to have better control over a bioreactor in the laboratory than on a pilot scale, and likewise, it is easier to have better control on a pilot-scale bioreactor than on a full-sized landfill. Keeping this in mind, this paper will first look at how one would best operate a laboratory-scale bioreactor and then try operating a full-scale landfill in the same manner to the extent where it is possible, practical, and where any added expense to do so is evaluated against the benefits that can be derived by operating in this manner.

A laboratory-scale bioreactor would include but not necessarily be limited to the following features or techniques to optimize its operation:

- Complete mixing
- Moisture addition
- Aeration or oxygen depletion
- pH adjustment
- Nutrient addition
- Temperature control
- Sealed container with defined boundaries
- Accurate and representative sampling
- Accurate measurement

Complete mixing in a bioreactor would not only include some manner of stirring to ensure even distribution of moisture, oxygen, nutrients, etc., but would also strive to make the waste mass as homogeneous as possible. The particle size of the waste must conform to the size of the reactor and the mixer for effective mixing and homogeneity to occur. Therefore, it would be advantageous to minimize the particle size, which would increase total surface area and

---

allow more complete mixing, both of which would accelerate and/or optimize a bioreaction. Preprocessing of the waste, such as shredding, would be desirable.

Moisture addition controls on a bioreactor would allow optimization of the water necessary for the bioreaction. Typical waste received at a landfill does not contain sufficient moisture for optimum bioreaction. The bioreactor may have several inlets for the introduction of moisture for even distribution.

If it is desired to operate the bioreactor in an aerobic mode, the inclusion of an aeration device would be necessary. A fine bubble diffuser may be considered for this purpose in a laboratory-scale bioreactor. The most efficient and complete distributor of oxygen to all parts of the reactor would be the desired goal.

Conversely, if it is desired to operate the bioreactor in an anaerobic mode, the exposure of the reactor to the atmosphere or an oxygen source would need to be eliminated. On a laboratory-sized bioreactor, this is relatively easy to do.

It should be noted that I do not advocate the operation of a landfill either in the aerobic or anaerobic mode. Landfills in operation typically have an aerobic zone near the surface and an anaerobic zone deeper in the fill. If it is desired to operate a landfill as an anaerobic bioreactor, then measures must be taken to reduce or eliminate the presence of oxygen near the surface of the fill.

To help control the rate of the bioreaction, pH adjustment may be required. The bioreactor may have several inlets for the even distribution of chemicals to raise or lower the pH as required.

If the waste mass is nutrient deficient, the addition of nutrients such as phosphorus or nitrogen may be desired. Again, it may be desirable to have several inlets in the bioreactor for the even distribution of nutrients.

The control of temperature in a bioreactor can be extremely helpful in optimizing the bioreaction. Although bioreactions can proceed in generally wide temperature bands, they run at much faster rates at the optimum temperature range of 45°C to 65°C. A laboratory-scale bioreactor already has the advantage of operating in a climate-controlled building. In addition, if necessary, it is very easy to insulate and heat a laboratory-scale bioreactor.

A laboratory-scale bioreactor consists of a small container that can be sealed and calibrated as required. This allows for very good control of the bioreaction.

Due to the small scale of a laboratory bioreactor, it is relatively easy to obtain accurate and representative samples. Likewise, it also allows easy measurements of the contents and of the amounts of water, oxygen, nutrients, etc., which are added to the reactor.

As stated previously, the benefits of operating a full-scale landfill as a bioreactor include the acceleration and control of the biodegradation process and the increased compaction density of the waste. Acceleration of biodegradation in a landfill could:



- Lessen risk in the case of liner system failure
- Increase the production of landfill gas
- Provide a method for using and treating leachate

No one knows for certain what the effective life of a landfill liner system will be. Current design requirements under Subtitle D and most state environmental regulatory agencies dictate that landfills must be constructed to "entomb" wastes. Waste placed in a landfill under these conditions will biodegrade at extremely slow rates, which then forces more reliance upon the longevity of the liner system. Therefore, it may be very advantageous to accelerate the rate of biodegradation in a landfill to hasten rendering of waste and leachate to a relatively inert condition. This would reduce the risk of environmental damage in the long term due to the uncertainty of the effectiveness of the liner system.

Accelerating the biodegradation process would also increase the production of landfill gas, which could be beneficially used as an alternative to natural gas or as a fuel for internal combustion engines that can produce electricity.

Leachate could be used to help accelerate the biodegradation process. It could provide the additional moisture, nutrients, or pH adjustment needed. Using leachate in this manner would avoid the expense of having to treat or dispose of the leachate. Continuously recirculating leachate back into the landfill bioreactor would also provide a means of pretreating the leachate.

Operating the full-scale landfill as a bioreactor would increase the density because the waste particle size would be smaller. The decomposition of waste before placement of the final cap would also reduce the total mass to be landfilled. This would provide the benefit of using less landfill volume per ton of waste received, thereby extending the useful life of the landfill.

Incorporating bioreactor techniques in a full-scale landfill could be accomplished as described below:

- **Complete mixing.** To reduce the particle size of waste, shredding or trommeling may be used. This would also provide a way to enhance the removal of metals, plastic bottles, glass, and other items that will not biodegrade and are recyclable. With the reduced particle size and removal of inert materials, a more homogeneous waste that can be more readily mixed by conventional equipment is possible. Mixing for an aerobic bioreactor may be performed using a front-end loader to turn over the pile or even a windrow compost turner machine. Shredding or trommeling would provide the required mixing for an anaerobic bioreactor.

To keep the waste in the landfill bioreactor as homogeneous as possible, the goal would include eliminating soil cover if possible. A typical landfill may use between 15 and 30 percent by volume of soil cover. This would cause severe problems to ensure complete mixing and homogeneity. The use of moveable geosynthetic covers or foam covers would help address this problem. Alternate covers such as these require regulatory approval, however. The alternate

covers may not provide sufficient fire protection or odor control and may need to be supplemented with soil.

- **Moisture addition.** In a full-scale landfill bioreactor, moisture addition typically is provided at least in one fashion involuntarily by rainfall events. To have full control of the rate of moisture addition, one would have to provide a roof or cover over the entire landfill. Moisture could be added by using leachate from the bioreactor and from other landfill areas if necessary. Effective addition of moisture could be accomplished by injection into the trommel or into the waste mass after it has been shredded or by spraying it onto the waste mass at the landfill face. In a closed landfill, cell moisture addition could be injected into wells or pumped into seepage beds.
- **Aeration or oxygen depletion.** In a full-scale landfill bioreactor, aeration of the waste mass could be achieved by creating a compost pile and turning the mass periodically with a front-end loader or a windrow compost turner machine. Another method used by a landfill near Albany, New York, was the injection of air into the waste mass through perforated pipes into the compost pile. This aeration and composting stage must then be followed by the landfilling stage, which would operate under anaerobic conditions. When the landfill bioreactor is to be operated in an anaerobic state, the use of a foam cover may be desirable to provide oxygen-deficient conditions and not consume space as a soil cover would.
- **pH adjustment.** In a full-scale landfill bioreactor, pH adjustment could be achieved by spraying or applying the chemicals directly onto the landfill face. The chemicals could also be added in the same manner as the moisture described above. The pH of leachate could be adjusted, then it could be added for both moisture and pH requirements. Due to the large quantity of the waste mass, any adjustment to its pH would require significant quantities of chemicals.
- **Nutrient addition.** In a full-scale landfill bioreactor, nutrient addition could be achieved by applying the nutrients onto the landfill face. If in a liquid form, the nutrients could also be added in the trommel or after the shredder and could be added to any leachate that is recirculated into the bioreactor.
- **Temperature control.** In a full-scale landfill bioreactor, temperature could be controlled to some degree by covering the reactor with soil or alternate cover. Also, by virtue of its size, the landfill provides its own insulation. Controlling the bioreaction energy also controls temperature on this scale.
- **Sealed container with defined boundaries.** In a full-scale landfill bioreactor, two scenarios are possible. The first would be a closed landfill cell. The container in this case would be sealed with defined boundaries. Mixing would be impossible at this stage. Moisture addition, pH adjustment, and nutrient addition would be limited to injection methods, including recharge wells or leachate fields within the landfill. The second scenario would be an active

landfill cell where waste is added each day. The best available methods for containerization would be the use of foam or geosynthetic covers in the subcells.

- **Accurate and representative sampling.** In a full-scale landfill bioreactor that consists of a closed landfill cell, accurate and representative sampling of waste is expensive and difficult yet is necessary to determine the status of the bioreactor. Accurate and representative sampling of solids could be done by placing and retrieving time capsules of waste or by keeping very descriptive waste placement records so that representative samples could be excavated at later dates. Another method for retrieving samples is the use of specialized drilling rigs. This is very expensive and may not ensure a truly representative sample.

Accurate and representative sampling of liquids and gas is much easier and less costly. Leachate and landfill gas collection systems that are installed in most modern landfills allow retrieval of representative samples.

- **Accurate measurement.** In a full-scale landfill bioreactor, two scenarios are possible, as described previously. The first would be a closed landfill cell. Measurement of the quantity and quality of leachate and landfill gas could be done fairly accurately if a tight final cap exists. If a representative sample of waste could be obtained, it could also then be accurately analyzed. The second scenario would be an active landfill cell where waste is added each day. In this situation, an accurate measurement of the quantity of landfill gas is almost impossible because the "reactor" is not sealed. A sample of landfill gas may be obtained but is unlikely to be representative of the entire reactor. Conversely, an accurate measurement of the quantity and quality of leachate might be possible because the landfill leachate collection system would be fully functional in this scenario. Waste in this reactor would be in different stages of decomposition depending on its place within the reactor and the length of time it had been there.

Although there are many good reasons to operate a full-scale landfill as a bioreactor, there are some practical obstacles to overcome, including:

- Regulatory requirements
- Economics
- Odors

Regulatory requirements may not allow operation of a full-scale landfill as a bioreactor in some states. For example, recirculation of leachate back into the landfill is not allowed in some states. Also, the use of alternate cover materials that do not take up landfill volume, such as foams or geosynthetic covers, may not be allowed. More stringent liner systems may be required (as they are in Delaware) if leachate recirculation is going to be used. This increases costs.

To operate a landfill as a bioreactor, a substantial investment may be required for the additional equipment and labor needed. The landfill owner may not be able to afford the short-term investment for the future benefit.

Operating a full-scale landfill bioreactor, especially in an active, open landfill cell, has the potential to cause odors, which may be a problem if there are residences nearby. Leachate recirculation may have to be postponed until the cell is closed or until an active landfill gas collection system is operating.

In conclusion, bioreactor techniques may be incorporated into the daily operation of a landfill to help accelerate the biodegradation process, reduce the risk of liner system failure, increase the production of a potentially valuable resource of landfill gas, reduce leachate treatment costs, and increase the useful life of the landfill. In many cases, these benefits would outweigh the costs of implementing the bioreactor techniques.

## **Landfill Gas Enhancement Management**

---

John G. Pacey  
EMCON/FHC, Inc., Pebble Beach, California

---

### **Abstract**

There is considerable apprehension amongst a small but growing sector of professionals and regulators concerning whether U.S. waste should be deposited in environmentally secure landfills and left in their dry state to slowly decompose over the years. The need to manage and protect these secure repositories over the decades will fall to future generations; it is costly protocol and could lead to unwanted and unnecessary consequences.

This paper addresses not a new idea but one that has been demonstrated, discussed, and debated for several decades and is gaining more favor as we have finally achieved relatively secure landfills. Secure landfills finally give this industry an opportunity to work within the secure landfill framework to manipulate the decomposition cycle of the deposited refuse by amending composition, moisture, and selected parameters to rapidly decompose the refuse within a decade or two, thus removing the concern for long-term security, shortening the postclosure management program in numerous areas (e.g., monitoring of leachate and gas, regrading, and erosion control). Additional benefits include generation of more landfill gas (LFG) at higher rates than the average landfill thus fostering a better opportunity for a gas utilization project, rapid stabilization of the completed landfill allowing earlier beneficial use of the property, possible reuse of some of the landfill to receive additional refuse as space will rapidly become available during the filling cycle due to earlier rapid settlement of the initial refuse. These are but a few of the more obvious benefits, but the underlying theme is to remove this specific potential long-term worry from future generations.

This paper presents a discussion of the management options and goals relative to the use of a landfill as a beneficial bioreactor.

### **Introduction**

With the advent of the environmentally secure landfill, it is now possible to consider managing the contained waste in an effort to produce significant social, commercial, and environmental benefits, assuming that regulations and regulators are cooperative. This paper presents management goals associated with use of the landfill as a bioreactor; it proves some discussion based on experience gained from literature reviews, management of associated demonstration projects, and many relevant discussions with peers on this specific subject matter.

Management has many definitions; the following is specific to this paper:

management of a municipal waste landfill for the purpose of changing its LFG generation and extraction quantity and/or quality involves implementation of actions to improve the landfill's gas generation/extraction rate and yield and is achieved by controlling, directing, conducting, or administering the refuse composition or conditions, or the landfill operations to accomplish project goals.

One additional management goal associated with this activity is the use of the landfill as a leachate treatment bioreactor where many of the same management considerations and options are equally applicable.

It is important to recognize that an LFG enhancement project can address various goals, including but not limited to 1) enhancement of the LFG generation rate and total gas yield, 2) achievement of significant refuse volume reduction, 3) achievement of rapid refuse decomposition/ stabilization, 4) utilization of the refuse as a wet digester for leachate treatment, or 5) achievement of a combination of these goals in one project. Each of these goals is presented, followed by a discussion of some of the issues and management approaches.

All goals involve the addition of significant liquids to the refuse, thereby increasing leachate and gas generation rate and quantity. For such projects to be environmentally acceptable, it is necessary that environmental security and compliance be maintained. Leachate quality may be adversely affected, only during the early portion of the management program. It is generally agreed that management of such projects will attempt to minimize related costs, and thus, most efforts will probably try to minimize costly exotic or unusual operational protocols.

The parameters most commonly addressed to achieve the desired goals are readily identifiable. These include but are not limited to 1) liquid additions, 2) nutrient, pH, and temperature management options, and 3) density, particle size, and refuse sorting/separation management options. The issues associated with each parameter must be carefully researched and judgments made related to the cost/benefit, environmental compatibility and benefits, and landfill operational compatibility and desired performance.

## Goals

### *Goal 1            Management To Achieve an Increase in Landfill Gas Generation Rate and Total Gas Yield*

This goal is achieved by improving the anaerobic decomposition environment within the refuse. It can be enhanced by judicious management of the parameters that optimize the decomposition process, most notably liquids. Of secondary importance is management of nutrients and pH; temperature has also been considered in recent demonstration projects (Brogborough Landfill in England and Central Landfill in Yolo County, California). Temperature management is relatively expensive compared with other enhancement options.

---

The Mountain View Demonstration Project (see Table 1) embraced this goal; its purpose was to enhance landfill gas generation rate and total gas yield. Literature research and laboratory study for this project were completed by Dynatech in the late 1970s, followed by a field demonstration project managed by EMCON from 1980 through 1985 (1). It was recognized at that time (as a result of field and laboratory information) that LFG generation rate and the total yield could be increased significantly by selected management activities. The most effective and hence important variable to manage was liquids addition. Nutrient addition (to provide for needed bacterial trace elements) and pH addition (to provide a near-neutral internal environment) were managed as well as liquid additions.

The Mountain View Project considered liquid additions in three forms: 1) as a slug of water applied over a very short period at completion of cell construction, 2) as a limited amount of liquid added as a component of sludge during the cell construction activity, and 3) as an infrequent addition of recycled leachate to represent leachate recirculation. While not a planned management activity, it was observed that all cells gained liquid by lateral or basal inflow from surface or ground water during the project duration. Sewage sludge from a nearby sewage treatment plant was introduced in several cells, as was buffer in the form of calcium carbonate. Sludge addition was a normal practice at this landfill as was the method of its addition to the refuse.

This demonstration project was generally similar to normal landfill operations at the associated landfill: it differed in that no daily cover was utilized in constructing the 50-ft-deep refuse cells, and calcium carbonate was added in several cells. The cells were constructed over a period of 3 months, and it took another 3 months for the instrumentation and final cap to be installed.

The Mountain View results were extremely encouraging, even though there were problems with gathering all gas flow information and there was infiltration of external waters during the course of the project. All cells demonstrated a very high rate of LFG generation ranging between 0.25 and 0.60 scf of LFG/dry lb/yr. The project was terminated due to lack of funds and the need to complete the fill in the demonstration area, after 5 years of time. Yet the cells had generated between 0.61 and 1.48 scf of methane/dry lb.

### Issues

The Mountain View Demonstration Project results were remarkable as they demonstrated a rapid rate of gas yield and potential total yield in every cell based on actual measured data. Yet the demonstration cells were different in their construction than the adjacent landfill; the difference was in the rate of fill, absence of daily cover, and the final cap (Hypalon versus soil). Temperature in all cells was initially in the range of 35°C to 40°C and increased steadily for about 2 years, after which they were relatively stable. Temperature in Cells A, B, C, and E reached 55°C to 60°C; temperatures in Cells D and F were relatively stable in the range of 45°C to 55°C, even though these two cells were the apparent high generators. The inability to record flow data from certain cells for an extended time was, and remains, a

**Table 1. Summary of Cell Construction Characteristics and Performance: Mountain View Controlled Landfill**

|   | CELL  |       |       |       |       |        |
|---|-------|-------|-------|-------|-------|--------|
|   | A     | B     | C     | D     | E     | F      |
| Refuse deposited (dry tons)                                 | 5,500 | 6,120 | 5,380 | 6,610 | 5,530 | 6,220  |
| Additions   | sbwr  | sb    | sbw   | b(w)  | s(w)  | (none) |
| Moisture content (%), after construction wet weight basis   | 46    | 32    | 44    | 28    | 32    | 26     |
| Moisture content (%), after water addition wet weight basis | 69    | 54    | 50    | 33    | 45    | 40     |
| Porosity (%)  | 50    | 49    | 50    | 49    | 51    | 48     |
| Void ratio  | 0.98  | 0.97  | 1.01  | 0.95  | 1.05  | 0.92   |
| Unit landfill gas yield (scf/dry lb)                        | 1.28  | 1.09  | 1.43  | 2.61  | 1.09  | 2.23   |
| Unit methane yield (scf/dry lb)                             | 0.72  | 0.62  | 0.81  | 1.48  | 0.61  | 1.23   |
| Carbon conversion (%)                                       | 19    | 17    | 22    | 40    | 16    | 33     |
| Average generation rate (scf LFG/dry lb/yr)                 | 0.29  | 0.25  | 0.33  | 0.60  | 0.25  | 0.51   |
| Total LFG generated (million scf)                           | 11.1  | 9.7   | 11.9  | 26.4  | 8.4   | 22.3   |
| Average cell settlement (ft)                                | 6.7   | 7.2   | 7.6   | 4.2   | 7.7   | 6.1    |
| Leachate level (ft)   |       |       |       |       |       |        |
| Day 100   | 15    | 1     | 18    | 1     | 1     | NA     |
| Day 500   | 24    | 2     | 24    | 4     | 3     | NA     |
| Day 1,000   | 42    | 12    | 32    | 5     | 12    | 6      |
| Day 1,600   | 39    | 16    | 37    | 7     | 20    | 16     |

**Notes:**

1. Refuse deposited does not reflect buffer added (10 tons if added).
2. Additions: s is anaerobic digester sludge; b is buffer (calcium carbonate), approximately 10 tons; w is 60,000 scf of water; (w) is 8,350 scf of water (to reach field capacity); r is recirculation of leachate.
3. Calculated ultimate yield is 3.74 scf CH<sub>4</sub>/dry lb of refuse.
4. Cell A received an initial loading of 61,000 cu. ft in 72 hours, and recirculation commenced 1 month later. Cell C received 60,000 cu. ft over a 26-day period. Cell D and E received 8,300 cu. ft of water over a 14-day period about 6 months after the start of monitoring.
5. Initial cell refuse depth was 50 ft; most of the leachate was created by natural water infiltration.



puzzle. The gain in moisture (leachate level) over the demonstration period was not planned; efforts were made to discourage this from happening, but it did happen.

Mountain View demonstrated a successful, albeit not fully explainable, positive project. It is the most thoroughly documented and illustrative enhancement project yet completed.

## *Goal 2            Management To Achieve Rapid Volume Reduction*

In this approach, the landfill is used as a true anaerobic bioreactor. Management seeks to achieve a highly efficient optimal digester activity that will achieve rapid decomposition, thereby allowing the landfill capacity to be used more efficiently and effectively. If space is adequate and decomposition is rapid, then the capacity space might be used more than once during the landfill operation, which would extend landfill life.

The underlying consideration is that the organic fraction of refuse decomposes, and given adequate time, the organic fraction can be reduced to 25 to 50 percent of its volume. If the decomposition cycle can be altered from 20 to 50 years downward to 5 to 10 years, then some interesting and significant possibilities exist for extending the operational life of a landfill.

### Approach

The goal can be achieved by shortening the decomposition cycle. It would seem most appropriate to add liquid during construction; rainfall infiltration might be utilized as a component of the liquids management activity. Addition of liquid during refuse placement would initiate the methanogenic stage at the earliest time. This is also the best way to accomplish relatively uniform liquids distribution and achieve liquid equilibrium at perhaps the lowest cost of all the options. It is also possible to add calcium carbonate and sewage sludge during construction if pH control and/or nutrient addition management is to be included.

If part of the goal is to increase the site capacity efficiency, then a program of sorting/separation may be practiced to isolate the rapidly and moderately decomposable fractions for wet digestion management. If the program is restricted to a normal landfill program, then the management protocol would be very similar to that used for rapid refuse stabilization.

As mentioned above, one of the primary benefits from this management option is the improvement in site life and capacity available for waste volume receipt. If the results are that the site can achieve a realistic net gain in useful capacity of 10 to 25 percent or more during its operating life, then the economic and utilization rewards may be very significant. If rapid volume reduction is achieved, the stabilized landfill should also be environmentally stable. Portions of the landfill may be stabilized and ready for development prior to final closure. This should result in significant shortening of the postclosure monitoring and maintenance program and should facilitate overall site development relatively early.

### *Goal 3 Management To Achieve Rapid Refuse Stabilization*

This is a goal developers and landfill owners may seek to meet in order to shorten the length of postclosure activities and return the landfill to suitable end-use earlier than normal. A shortened stabilization time, whereby the organic fraction of the refuse has achieved most of its decomposition activity, will result in many environmental and postclosure cost savings and landfill performance benefits.

#### Approach

The approach is similar to that for achieving volume reduction, but the principal element is rapid site stabilization and end-use. Increased site life may not be a management objective. Liquid additions and other parameter management activities should be considered in the same light as for the volume reduction goal.

The Sonoma Demonstration Project (1971 through 1973) was patterned after this approach. The principal goal was to look at moisture management as the means to accomplish rapid stabilization of the refuse. Leachate parameter stabilization and settlement were the two main criteria for determination of the accelerated decomposition cycle.

### *Goal 4 Management To Achieve Leachate Treatment*

#### Goal

The goal is to use the refuse as a wet digester, similar to a trickling filter, to control pH and effectively remove and/or reduce the organic and inorganic product in the leachate as a means of partial leachate treatment. In this sense, the landfill refuse is a component of the leachate treatment system.

#### Approach

Leachate production is generally minimized in current and future landfills as an operational goal so as to minimize the associated treatment and environmental cost and liabilities. Leachate recycle projects may have this same goal or may expand the program to be a combined partner with one of the other enhancement goals. The leachate will be stored, transported, perhaps amended, perhaps receive temperature increase, then be reinjected as the leachate is recycled. Liquid makeup will probably be necessary to maintain the desired recirculation dosage, particularly where the landfills are in semiarid and arid regions and where the landfills are filled and covered in a few years and external liquids are not added during operations. The landfill of today is operated to minimize rainfall infiltration and restrict liquids addition. It is therefore probable that a leachate recirculation project will need considerable liquid makeup during operations, even in the wettest of regions.

The leachate recycle goal is the most aggressive of the liquid addition management options insofar as the management of a given quantity of liquid in a unit volume of refuse. The leachate recycle area might be limited to a small and environmentally secure portion of the landfill. The area selected may be sufficient to treat only the amount of leachate actually generated by the landfill operations and postclosure activity.

### Issues With Goals

The many questions related to these goals involve when to add moisture, nutrients, practice pH control, manage temperature, etc. Should the refuse be presorted to remove the inorganics and slowly decomposables? Should the nondecomposable fraction be recycled or disposed of in a site monofill? Should the decomposed product be mined and used for soil amendment, compost, or nonstructural fill?

Major issues associated with liquids management for each of the goals include the character of added liquids and the quantity, operation protocol, and timing of liquid addition. The liquid may range from relatively pure water to contaminated water, sewage sludge, septic tank pumpings, and other nonhazardous liquids. LFG condensate and leachate, even though they originate in the refuse, are not recognized by the U.S. Environmental Protection Agency (EPA) and water boards as being generically acceptable liquid additions even though they may be derived from the refuse. Even relatively pure water may not be allowed to be added to refuse in some states. Federal consideration of liquid amendments under 40 CFR, Section 258, may be relatively permissive if the purpose can be demonstrated to be "beneficial." Leachate recycling is acceptable in many states with some qualification.

Another liquid management issue is when and how to add the liquid; such discussion is subject to considerable individual preference.

Figure 1 presents the relationship between refuse density, water content, and saturation; it also suggests the approximate range of field capacity. Field capacity occurs in the moisture content range of 35 to 50 percent, with full saturation in the range of 40 to 55 percent, dependent upon placement density. This chart can be used as a guide for the quantity of liquid needed to achieve management goals. To achieve the goal of having a modest liquid movement together with a field capacity condition, management might elect to add only 300 to 350 lb of liquid/yd<sup>3</sup>, while at the same time managing the base hydraulic head to comply with regulations. If the goal were to practice leachate recirculation, then it would be appropriate to determine a rate of application that would optimize leachate treatment. This could be done in an area of the landfill reserved for leachate recycle if this were the only purpose for the recycle. If the goal were to stabilize the entire mass of refuse quickly, then it might be appropriate to continuously move a small amount of liquid through all portions of the landfill, although probably in a phased program. In this case, the amount of liquid would be in excess of 350 to 450 lb of liquid/yd<sup>3</sup> and makeup liquid would be necessary. By phasing the program, less liquid would be needed in total.

As a result of projects such as this, we now know that there are operational issues involved with liquids management (timing, quantity, quality, uniformity of application, and rate of application) that must be considered in developing the desired results.

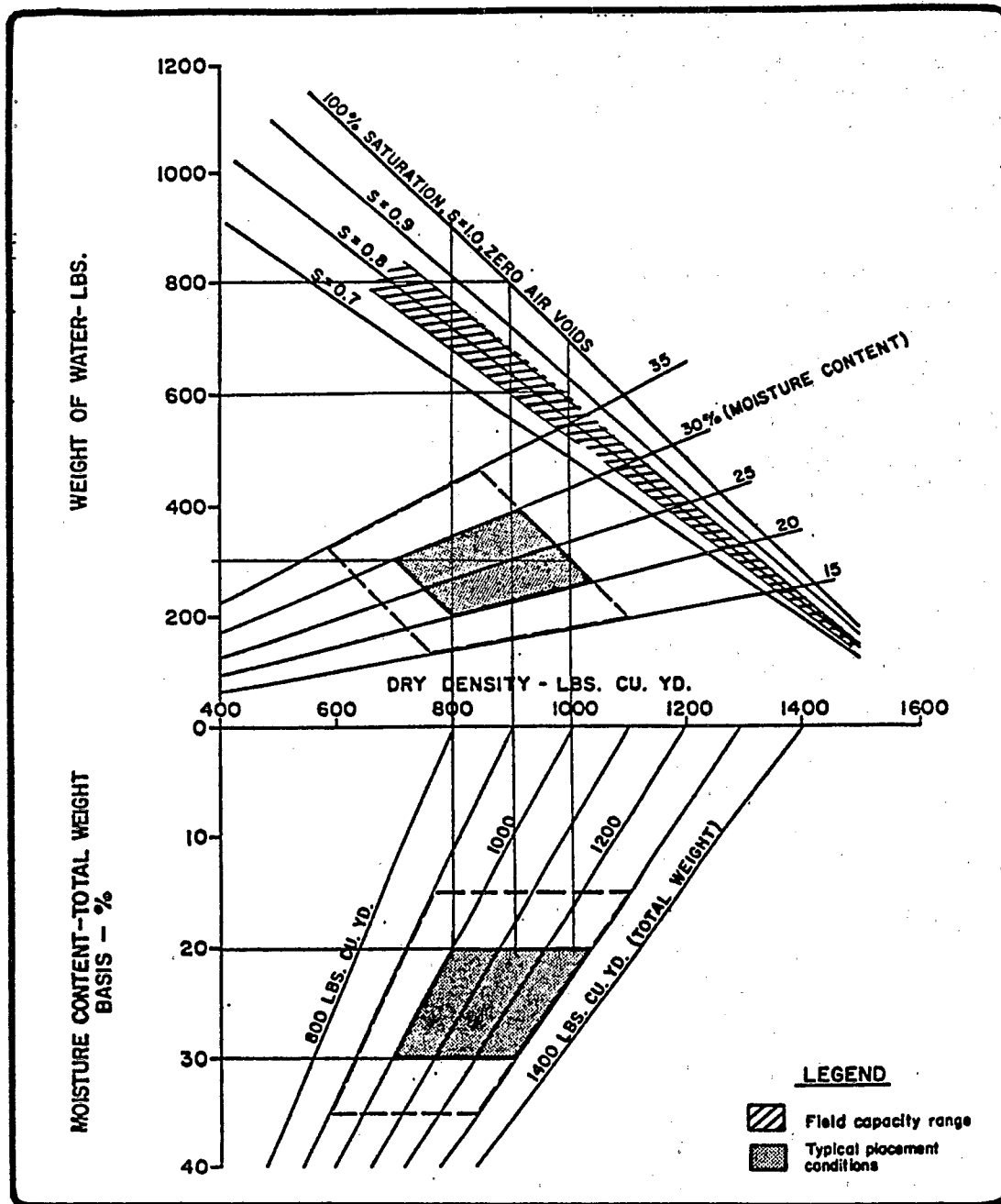

Figure 1. Relationship between refuse density, water content, and saturation.

A modification option to increase the LFG yield and rate per unit mass is to increase the organic composition by removal of inerts and slowly decomposable organics. The process can be more efficient if the refuse character is modified to remove most of the inerts and slowly decomposable organics (plastic, rubber, textile and tree limbs, roots and trunks). The program could then be reduced to a wet composting activity. The cost of sorting may be prohibitive and is subject to study on a case-by-case investigation.

### **Conclusion**

The environmentally secure sanitary landfill presents an opportunity for management of the refuse composition, operations, and design in such a manner as to cause rapid decomposition of the refuse so that the issues and liabilities of long-term care and maintenance are removed from the worries of future generations. This paper presents some of the goals associated with enhancement of refuse decomposition together with some of the issues and many of the benefits. The landfill bioreactor can be used to increase gas generation (yield and rate), increase settlement and stabilize refuse in a timeframe of 5 to 15 years, reduce postclosure monitoring and maintenance activities and costs, and increase landfill site life in most instances.

### **References**

1. EMCON. 1985. Controlled landfill project, Mountain View, California. Fifth Annual Report. Submitted to Pacific Gas and Electric Company and Gas Research Institute.

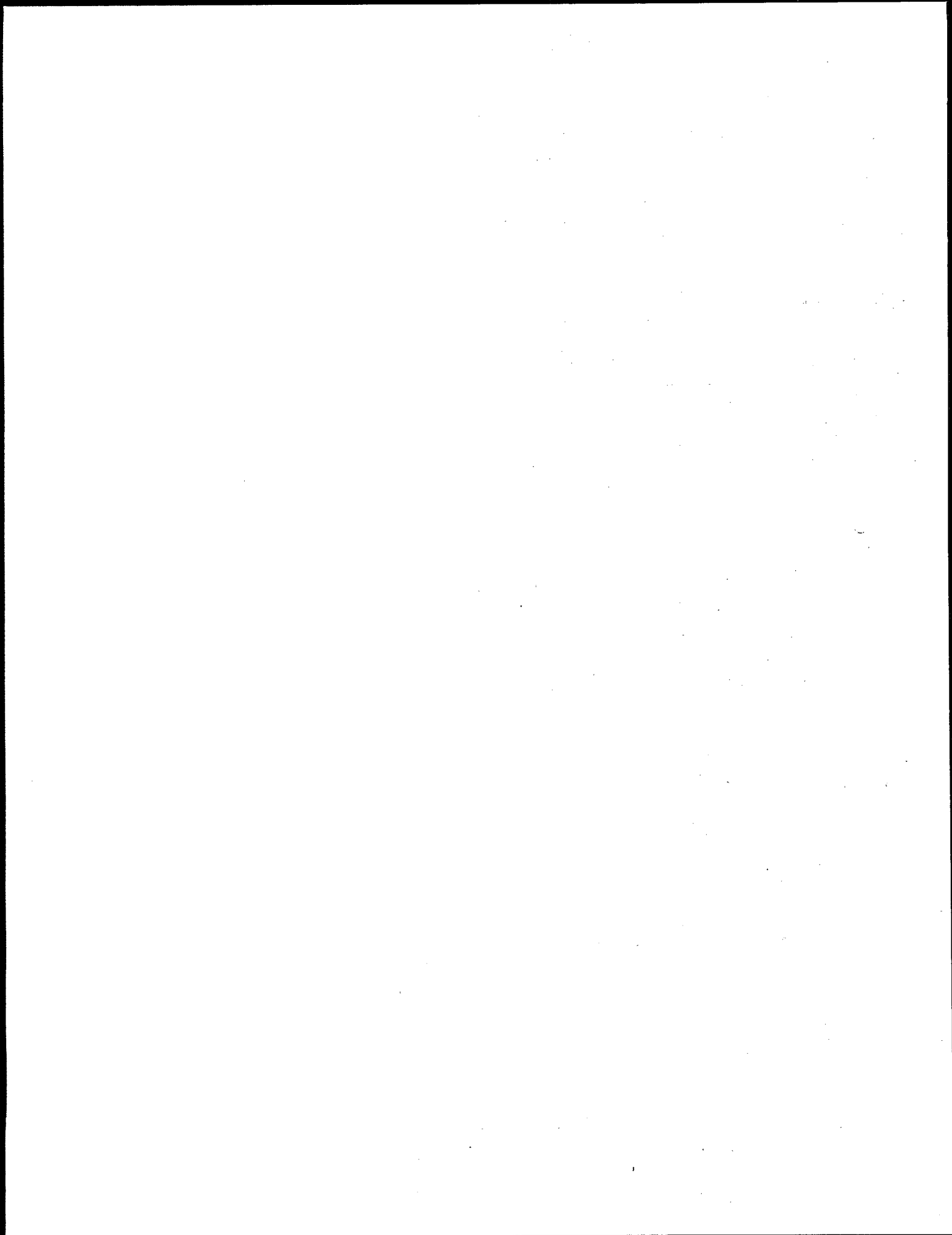

# **Landfill Leachate Recirculation From an Owner/Operator's Perspective**

---

Jeffrey M. Harris

Browning-Ferris Industries, Inc., Houston, Texas

---

## **Abstract**

This paper presents a discussion of leachate recirculation in a sanitary landfill from the perspective of an owner/operator. Numerous studies have been performed on the theoretical aspects of recirculation, and most have concluded that it is an advantageous procedure to optimize the performance of a sanitary landfill and minimize long-term environmental impact. As is often the case, however, the transition from laboratory study to field implementation faces many obstacles. Full-scale recirculation at an active landfill poses some unique challenges to designers and operators. Regulations, climate, cost, operations, and operator attitude are a few of the constraints that may dictate the form a site-specific recirculation program takes. This paper focuses on the benefits of leachate recirculation from an owner/operator's perspective and various operational issues of particular concern to a landfill operator. The paper also presents two case histories of field-scale recirculation projects, one using simplistic techniques, and the other using a more rigorous, documented, systematic approach.

## **Introduction**

Recirculation of leachate is a topic that has received a high level of interest in the past few years. Much work has been accomplished in laboratory and small-scale studies that seems to verify the effectiveness of the concept. While a few states allowed leachate recirculation in past years, most disallowed it until the Subtitle D regulations (1) established a consistent regulatory framework. Now that regulatory acceptance is more common, landfill owner/operators are striving to install efficient, cost-effective systems. This paper considers the subject of leachate recirculation from the perspective of a landfill owner/operator. Owner/operators are typically driven by operational and economic considerations. For both private and public landfills, the first goal is to place and cover trash in an efficient and environmentally secure manner. Private operators are also concerned about the profitability of the operation.

## **Why Recirculate Leachate?**

The potential benefits of leachate recirculation to an owner/operator are much the same as those demonstrated in laboratory studies. Some of these are listed below:

- Reduction in the cost of leachate treatment and disposal.
-

- Increased quantity and quality of landfill gas for use in energy recovery projects and early stabilization of the landfill.
- Enhancement of landfill settlement and possible opportunity to recover air space.
- Early stabilization of the landfill leading to reduced closure accruals, postclosure time, and cost.

The final item on the list above, early landfill stabilization and control of closure costs, is probably the major driving incentive for owner/operators to pursue recirculation. The long closure periods required under current regulations create a significant cost liability for owners.

### Concerns Related to Field-Scale Implementation of Recirculation

There are some valid concerns about implementing a recirculation program at an operating landfill. For example:

- Some regulators and regulatory agencies, accustomed to years of enforcing regulations that prohibited recirculation, are now reluctant to approve permit modifications that allow this form of leachate management. Some regulators seem to feel that recirculation is a ruse by owner/operators to avoid leachate management costs.
- Operating landfills are difficult environments for in-fill recirculation system components. Typical operations involve heavy equipment such as scrapers, dozers, and compactors moving across the active area of the landfill. The view from the operator's seat of this type of large construction equipment is such that operators often cannot see vertical obstructions such as manholes or settlement plate access tubes. Further, vertical structures that are designed to be extended upward as the landfill height increases make it difficult to place and compact trash in the vicinity. Heavy equipment loading may also tend to crush piping system components that are installed as filling progresses.
- There is some concern that the initial result of recirculating leachate will be an increase in the concentration of contaminants that may preclude utilization of existing agreements with publicly owned treatment works (POTWs). Some evidence lends credence to this argument. A BFI San Francisco area landfill that recirculated leachate by application to the working face over a period of several years found that concentrations of certain parameters exhibited a steadily increasing trend to the point that one or more parameters exceeded the POTW industrial waste acceptance criteria. The landfill operators felt that the recirculation practice was worsening this condition, and they temporarily stopped. There has not been sufficient time yet to determine if the trend will gradually reverse.



- Leachate outbreaks along above-grade sideslopes are a perennial concern for landfill operators. Many operators are concerned that recirculation may exacerbate the problem with outbreaks, particularly if a relatively impermeable daily cover was used during construction of the landfill.
- Odor may be a concern for recirculation systems that use direct application to the working face or infiltration trenches.
- Economic issues are often a concern. The landfill business has become extremely competitive and cost sensitive in recent years. Some operators feel that investing the money to construct and operate a recirculation system will cause them to be noncompetitive with other area landfills that do not recirculate. Another, opposite problem can result from economic pressures. If a landfill operator is struggling with the high cost of leachate management and perceives that recirculation of 100 percent of the leachate generated will result in a zero disposal cost, there may be a tendency to put too much leachate back into the fill. Operators must be educated that for most areas east of the Mississippi River with annual average precipitation in the 30- to 40-in. (760- to 1,016-mm) range, recirculation probably will not be an answer for all of the leachate generated and other treatment/disposal options must be available.
- Landfills, like most other businesses, tend to operate with lean staffs. Each "new" system (e.g., gas collection, leachate collection, storage, treatment, recirculation) tends to increase workload on an already strained staff. Alternatively, hiring additional staff increases overhead costs.

In addition to the potential concerns listed above, some site operators also may be resistant to institute a program of leachate recirculation. Possible reasons for this reluctance include resistance to change, the feeling of "just another thing for me to worry about," and other operational concerns, either real or perceived.

### **Need for Ranges of Systems**

While engineers and scientists have struggled with designing a recirculation system that optimizes the distribution of liquid throughout the waste mass, it is also important to understand that there will, of necessity, be a wide range of systems to apply to various economic, climatic, and operating zones. From an economic standpoint, for example, landfills in some areas of the United States currently have tipping fees in the range of \$12/ton to \$16/ton. Others, in highly urbanized areas of the northeastern United States, have tipping fees in the \$40/ton to \$60/ton range. Also, the cost of treating and disposing of leachate varies from site to site, ranging from less than a penny per gallon to nearly 30 cents per gallon. The relationship between leachate cost and tipping fee is crucial. As the cost of leachate management increases as a percentage of the tipping fee, a strong incentive develops to implement a cost control program, which may include recirculation. In other cases, where leachate is managed for a very low unit cost, the cost of installing, maintaining, and operating a recirculation system may exceed the cost of the current leachate management option. While

this may be a short-term rather than a long-term outlook, budget performance is judged on a short-term basis.

## Case Histories of Leachate Recirculation at Two Operating Landfills

### *Case History I: Tessman Road Landfill*

BFI owns and operates the Tessman Road Landfill, located near San Antonio, Texas. The climate in the area is relatively dry with an average annual precipitation of 28 in. (711 mm). Mean annual Class A pan evaporation is 80 in. (2,032 mm), and mean annual lake evaporation is 56 in. (1,422 mm). The landfill began recirculating leachate in late 1994 after receiving approval of the Subtitle D modification package from the Texas Natural Resource Conservation Commission. The Tessman Road Landfill has a Subtitle D single composite liner consisting of 24 in. (610 mm) of compacted clay and a 60-mil (1.5-mm) high-density polyethylene (HDPE) layer. Leachate from each cell flows via collection pipes to a sump. Leachate is removed from the landfill using sideslope riser pipes and submersible electric Grundfos pumps rated at 30 gal/min (114 L/min). The sideslope riser surface completion includes a 4-in. (100-mm) discharge hose from the submersible pump with a quick connect fitting at the top of the slope. A flexible 4-in. (100-mm) hose is connected and routed to the infiltration trench, and the leachate pumps are manually started. The leachate pump level control system is designed to operate in a manner that keeps the head on the liner to 12 in. (300 mm) or less.

The site chose a recirculation method that could be implemented immediately with minimum expenditure of capital. Leachate is pumped from the landfill sumps directly to an infiltration trench located above and behind the working face. The landfill area where recirculation is being practiced is currently about 30 ft (9,144 mm) above ground level. The infiltration trenches are dug daily, except on wet or rainy days. The trenches are cut with a track-mounted backhoe or a dozer. The trenches are typically 4 ft (1,200 mm) deep, and while the length varies, trenches are typically 40 to 50 ft long (12,000 to 15,000 mm). The trenches are kept well away from the aboveground landfill sideslopes to minimize the potential of sideslope seepage. The trenches are backfilled and covered with daily cover at the completion of the recirculation and prior to the end of the day's operation. Because the landfill is continually filling, the trench location progresses across the width of the landfill and continues at various vertical intervals as the landfill height increases. The downside of the infiltration system is that once the trench is backfilled and covered with additional trash, no additional liquid application can be accomplished at this level.

Site personnel maintain a log of recirculation activities. The amount of leachate recirculated varies, but it averages 5,000 to 7,000 gal (18,900 to 26,500 L) for each day of recirculation. Recirculation is accomplished on an as-needed basis (to maintain leachate head over the liner to less than 300 mm) but typically occurs two to three times per week. To date, the site has not experienced any odor or ponding problems.

## *Case History II: Lyndhurst Landfill*

BFI owns and operates the Lyndhurst Landfill, located near Melbourne, Victoria, Australia. Site personnel have tried several forms of recirculation in past years, so BFI decided to implement a formal trial program. The project was funded (approximately U.S. \$150,000) by the BFI Corporate office to avoid any financial disadvantage to the site. The Department of Civil and Agricultural Engineering of University of Melbourne was engaged as the third-party technical advisor.

A discrete disposal area known as Cell 3A was chosen for the test program. The cell dimensions are approximately 560 ft by 246 ft (170 m by 75 m). The cell depth averages 36 ft (11 m) with 3H:1V sideslopes. The liner consists of 3 ft (1,000 mm) of compacted clay with a permeability of  $1 \times 10^{-7}$  cm/sec. Above the base liner is a leachate collection system consisting of 1 ft (300 mm) of granular material with 3.5-in. (90-mm) diameter slotted pipes at 50-ft (15,000-mm) centers. Total annual rainfall is 33.6 in. (854 mm). The mean annual pan evaporation is 48 in. (1,227 mm). On average, potential evapotranspiration exceeds precipitation except from May to August.

Prior to filling, the cell was divided approximately in half, with one half being a nonrecirculated control cell, and the other half having leachate recirculation. Each half of the cell is served by a separate collection system and sump. A compacted clay divider berm was constructed in successive lifts to segregate the two cell halves. The cell was filled with select municipal solid waste (no industrial or special waste) over a period of about 18 months. Settlement plates of 24 in.<sup>2</sup> (600 mm<sup>2</sup>) were installed at 6.5-ft (2-m) vertical spacing. The location of each settlement plate was carefully surveyed and documented. At the completion of filling, a borehole will be drilled to each plate and a casing installed so that regular elevation surveys can be conducted. Original plans called for a 1-in. (25-mm) steel pipe to be welded to the settlement plate and extended upward as landfill filling progressed. The survivability of the vertical obstruction in a landfill environment was questionable, however, and the drilling option was selected.

The original design intention for the recirculation system was to construct horizontal trenches at three elevations within the cell. The trenches were to be filled with a slotted pipe and a granular backfill. Site operators determined that this plan caused difficulties with normal landfilling activities and revised the design to incorporate horizontal trenches only in the final lift and a series of drilled recirculation wells. A total of 16 recirculation wells are proposed at an approximate installed cost of \$1,450 each.

Moisture measurement in a refuse cell is a critical parameter for optimization of leachate recirculation but not an easy one to measure in the nonhomogeneous waste mass. The University of Melbourne proposed using a neutron probe inserted through an in-situ aluminum access tube for measurement of moisture content. The probe was calibrated to leachate from the cell. Initial laboratory testing indicated that the high-salinity leachate did not have any significant effect on the neutron probe count as compared with the test carried out with fresh water. Field calibration of the neutron probe, however, was less successful as the determination of volumetric moisture content of the refuse was complicated by many factors, including the composition and degree of compaction of the wastes. Establishment of a site-specific calibration curve has proven difficult.

For further water balance calculations, an on-landfill automatic weather station was installed. This weather station records rainfall, humidity, solar radiation, and wind speed. All surface water runoff from the test cell will be directed to a single discharge location and measured.

Recirculation is expected to begin in summer 1995.

### **Future Developments**

Leachate recirculation is one of many management tools that will likely be used by owner/operators to reduce the cost of leachate treatment and disposal. It is reasonable, however, to expect that other techniques will also be developed. For example, there is considerable current interest in planting fast-growing trees on the cap of a closed landfill. Poplar and willow trees are varieties often mentioned. While this option would require approval of an alternate cap design, some preliminary studies seem to indicate that a well-designed tree installation can uptake most of the moisture falling on a landfill and prevent it from becoming leachate.

Another development of considerable current interest to owner/operators is the use of landfill gas to evaporate leachate. This option destroys the organic fraction and eliminates the necessity of offsite discharge of liquids. This, possibly in conjunction with recirculation, could dramatically reduce or eliminate leachate requiring offsite management.

Alternative materials, such as chipped tires and pulverized glass recovered through recycling programs, may be used to construct recirculation system components. These types of materials can replace expensive granular materials and provide a beneficial use for the recycled commodity.

### **Conclusion**

Leachate recirculation has been successfully proven in laboratory studies for some time. Now that Subtitle D regulations are in effect, and with them the threat of environmental impact due to leaking landfills minimized, it is time to develop "smarter" waste disposal alternatives. It seems senseless to entomb municipal waste in dry encasements that will stay virtually unchanged for decades. This is not a wise environmental management choice, nor is it a prudent financial choice for owner/operators. We can be certain that new challenges will arise as the technology becomes more widely accepted in the field. We, as engineers, landfill designers, and regulators, must do our part to make recirculation and other advanced landfill management tools a functional reality that is mutually acceptable to the owner/operators, regulators, and general public.

## References

1. Solid Waste Disposal Facility Criteria, Final Rule, 40 CFR Parts 257 and 258. 1991. Federal Register 56(196): 50,978-51,119. October 9.
2. Lu, J., et al. 1985. Leachate from municipal landfills. Park Ridge, NJ: Noyes Publications.
3. U.S. EPA. Containment of heavy metals in landfills with leachate recycle. EPA 600/9-81-022a. Washington, DC.

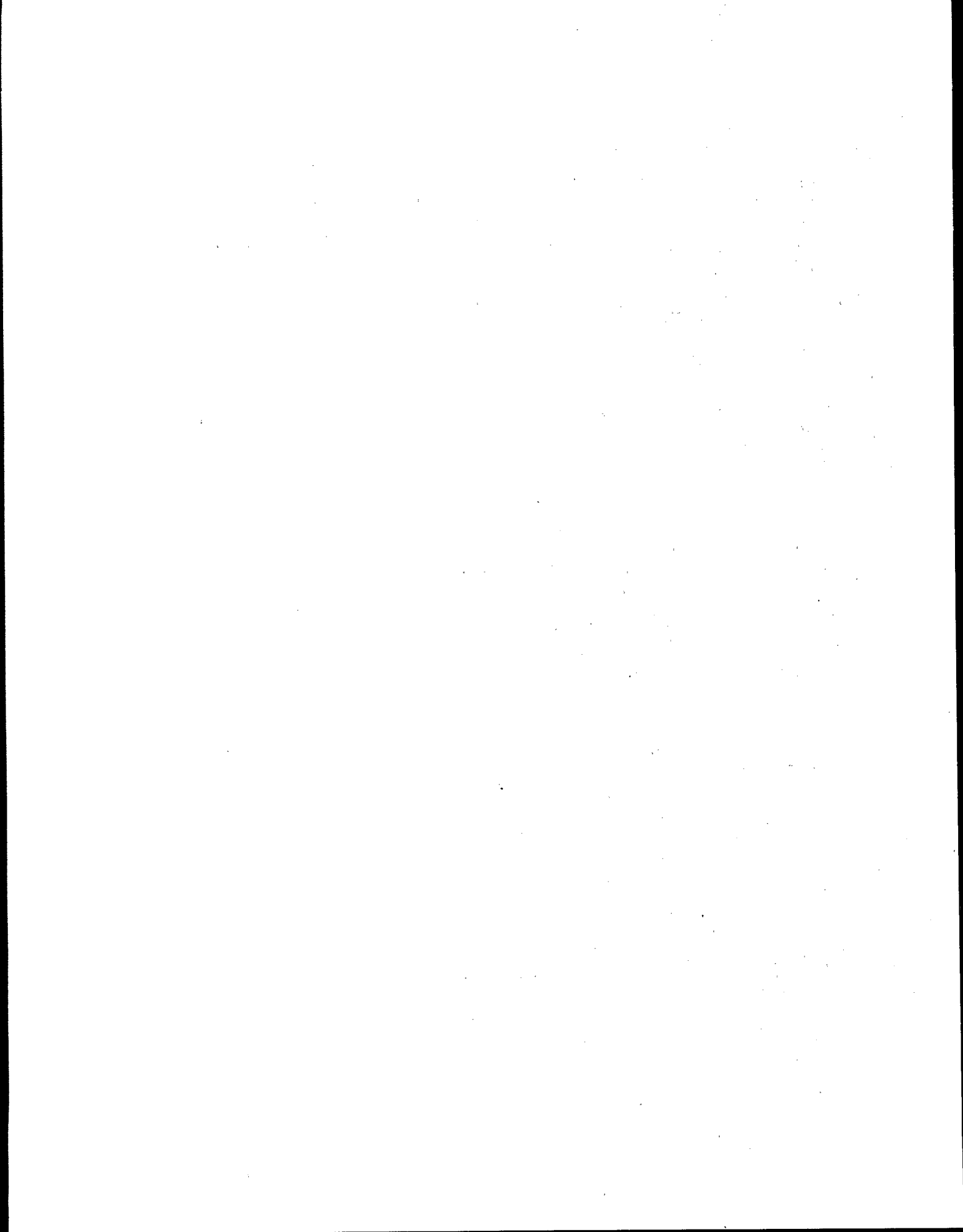

## Panel Discussion

---

The text that follows was transcribed from a question and answer session held in the evening of the first day of the seminar, March 23, 1995. The discussion was informal, and the following text has been edited for readability. Bracketed text has been modified. It is believed that the essence of the comments remains; however, participants in the discussion session have not reviewed the editing of this summary. Mention of commercial products or trade names does not constitute endorsement. The remarks are the opinions of the panelists, not necessarily those of the U.S. Environmental Protection Agency (EPA). Refer to the speaker list in Appendix A or the attendee list in Appendix B to determine the affiliation of each identified speaker. "Questioner" and "Panelist" are used when the speaker is unidentified.

### Questioner:

[How can I convince my client to implement leachate-recirculating municipal solid waste landfills?]

### Campbell:

The finance issues [associated with postclosure monitoring can influence the decision to implement bioreactor technology and can be influenced by regulators in the United Kingdom process]. If you start looking at what the costs are for long-term monitoring, over 50, 60 years, maybe, on a monthly basis, for gas migration, leachate monitoring, whatever it is, and you look at what that's going to cost you, I reckon if you can save 20 or 30 years, it's worth it.

### Questioner:

Yes, but I have to be able to tell him that he's not going to have to monitor forever? What I'm saying is that, if we do this now, that's going to allow you in the future to reduce your monitoring. I don't know that I can say that. That's more a regulatory issue.

### Campbell:

No, I think it's the operators' responsibility, and the operators have got to realize that is the reality of life. We would not allow an operator like that now in the U.K. We have some called "fit and proper" people. You cannot be an operator of a landfill unless you are going to take on those responsibilities. It's got nothing to do with regulators, and all that guidance is coming from the operators. The large companies that we have in our country [are] the people setting the regulations and guidelines, not our regulators. It's a very different situation in [the UK than in the United States].

**Panelist:**

I think I'd like to offer one suggestion to you. I think the esoteric arguments about recirculation are great for meetings like these about the long-term reduction and liability, but for a client like you have, I think you just have to look at the bottom line. Every gallon of leachate that he extracts has to be dealt with in some manner. Presumably, he'll treat it at an offsite POTW [publicly owned treatment works] or do something that has a definitive cost with it. If you can somehow make the argument that recirculation will either offset that cost or that he may actually gain air space by proper management using recirculation techniques, my feeling is that's the argument that would convince him. It's short-term economics probably more so than long-term environmental benefits.

**Questioner:**

That's the kind of things I'm looking for. For example, if you recirculate the leachate, supposedly you won't have as much to treat or to haul to a POTW. Are there good estimates? I know it varies from site to site and from locale to locale, but could I say to him, you'll save 50 percent, you'll have to treat 50 percent less leachate or 40 percent less leachate?

**Panelist:**

Well, Lamar Miller says he's recirculating 66 percent, I believe. I generally use the number 40 percent if I'm doing a cost estimate unless you're in a very dry climate like Arizona or California. The newest version of the HELP [Hydrologic Evaluation of Landfill Performance] model also has a recirculation subroutine in it, and I know the HELP model has a lot of limitations, but it is one reasonably well-accepted argument that you might look at.

**Campbell:**

That's a good point. I hadn't noticed that they had a recirculation model.

**R. Koerner:**

I'm Bob Koerner. I'm pinch-hitting for George, who had to return. I think the leachate aspect certainly is the initial cost factor, but I'd like to talk a little bit about downgradient monitoring wells, the cost of that type of system of the wet chemistry that's involved, and of the fact that the significance becomes more important as time goes on. You mentioned 60 years when the monitor goes; whether it's 60 or 600, it doesn't matter, but as time goes on, the necessity for that monitoring becomes more intense, not less intense. And I think if you [calculate the] time value of money and say that this is a technique by which you need less and less reliance on long-term monitoring, you can make a very poignant argument for money in today's present worth that says this type of system is very value-added to the entire landfilling [approach].



**Panelist:**

Well, I'm not an expert on the regulations, okay, but he monitors the landfill because he has to, because the regulations require it. So will I be able to say to him, well, if you put in this recirculation system, then somewhere down in the future you can either do away with or [reduce] your monitor[ing]?

**R. Koerner:**

It's a dynamic that's happening, and as I go state by state, I see more and more states looking seriously at double-liner systems and less reliance on downgradient monitoring, like New York State, Bob Phaneuf from his group has done. And I think people are beginning to challenge, regulators are beginning to challenge the value of monitoring, who's looking at this data, who's keeping track of it, and is it just a business that's feeding itself, or is it really protecting the environment? And I think we're seeing a shift, certainly in the mid-Atlantic and New England states. I don't know, maybe others have more experience in the western United States and in the southern states. But it's going to take time, it's not here now, but certainly the questions are being asked.

**Phaneuf:**

From a regulatory perspective—Bob Phaneuf, New York State Department of Environmental Conservation—to address your comments on monitoring, land disposal facilities are—we're obligated, even in your state now with the [Resource Conservation and Recovery Act (RCRA) Section] 258 requirements to monitor ground-water quality at land [disposal] facilities. That's a fact of life. Containment systems are there. I think you're still going to always see some form of ground-water monitoring at these facilities, but the extent added is, as Dr. Koerner pointed out, that we can probably minimize some of that. I had dinner with a landfill operator from Idaho, and he said, with the monitoring and the amount of money that goes into this, it's like you get a landfill permit, but you also buy an analytical lab to go along with it. (Laughter.) So there's an awful lot of money that's spent on monitoring. I think that if we get into monitoring at the facility concept of it, we can maybe back off on some of that and minimize some of that analytical cost. As far as convincing somebody—you know, why should I even consider the concept of landfills as a bioreactor? Because quite frankly, a lot of our reactions here as a regulatory agency are from what we see in trying to site these facilities. We'll have the lay public out there bringing up the hermetically sealed chicken pot-pie concept here of the facilities. You know, how long is the liner system going to be functional? I mean, I've been on the phone with Dr. Koerner a number of times asking him, well, how long is it going to be functional? Because I know I'm going to be put on the hot seat when I go to a landfill here. And these issues do come up, and they're real issues. You use a forum such as this to say, hey, this is something that's potentially an issue, the long-term has that, so these things have to be looked into.

**Leszkiewicz:**

There are two things that are happening simultaneously here, now. One is the evolution of the technology and the application of the bioreactor concept to landfill management. The other is the tailend of the jury coming in on the dry-cell technology, which is the driving force behind this. And as I said early in my presentation, the assumptions that a lot of people have made based on our historical evaluation of our experience in landfills have been that if you create this entombment process but have enough moisture in it at the time when you zip it, it is going to continue by itself to cook out, and you don't have to worry about the long-term issue. But if we start getting a lot more data [from] other landfills, it's starting to show us that as soon as we zip it up, we freeze-dry it. A lot of people are going to start saying, "Uh-oh!" "What are we doing?" "Are there other options?" "What should we be looking at?" And you have another option in the process of being developed.

**Pacey:**

I'd like to respond, also. John Pacey, EMCON/FHC. What you see here is a group of forward-thinking, sometimes some entrepreneurs, some regulators, people that have an idea that we all like. The [problem] is, unfortunately, we're a small group. What's been put in place, as far as regulations and actions, is the use of double-liners, composites, double, triple composites. And to change that is not going to be an overnight activity. So if you go back and talk to your clients, you can tell them you were out here with a creative type of a group. Things are going to happen in the future, but if you try to go on and tell the regulators today that you're going to cut down your monitoring timeframe, I think you've got a battle on your hands. You may be able to do it. All of us think we can, and we're going to be trying, but I don't see it here today. So while you're trying to make that quick change, if you will, to your client and give him some enthusiasm and some encouragement, I'd like to see you do that, but I'd like to also see you keep the practical. If you can find someone who's doing a lot of these [things], my hat's off to you. I don't know very many that are doing these things and in all states. There are a few states that are receptive to discussing it, but you're still asking for variances. I believe [Dr. Reinhart has some interesting statistics on the implementation of this technique], don't you Debbie?

**Reinhart:**

Yes.

**Pacey:**

Didn't you say there were only seven states that didn't consider it? I don't think you said there were only seven states that wouldn't allow it.

**Reinhart:**

Yes.

**Pacey:**

So do you feel that, from your knowledge, there are 43 states who would allow you to go ahead with leachate recirculation today?

**Reinhart:**

That's what they told me.

**Pacey:**

Yes, but you've got to have a fair answer or you've got to have a site-specific type of thing, I believe. I was just down looking at one in the Suffolk area, the Sybsill Landfill there, which was an interesting landfill that they—growing fast, and I think it's a battle. It would be a big battle, and a lot of clients just don't want the headache of a big battle.

**Fagan:**

My name is Dennis Fagan. I'm an environmental consultant from Elmira, New York. The question is somewhat directed toward the gentleman from EPA, but I'd certainly solicit comments from our distinguished panelists. Today, we heard some comments regarding the impact of caps, the timing of caps relative to the waste-stabilization process. I have heard in the past that the reason [the federal regulation] requires caps to be as extensive there as the landfill liner system is due to the bathtub effect. And yet with some of the work that George Koerner has done regarding what I would term second-generation leachate collection-system designs, it seems that EPA is totally ignoring the ability to remove leachate, the essence of a liner system, the leachate-removal system design of not having had the primary liner system to minimize the leakage potential. Why in God's name do we have to go with the extensive caps that EPA is requiring with their regulations?

**Miller:**

Let me [preempt my] compatriot from EPA. Hi. Lamar Miller. I don't know whether you remember my introduction or not, but I've spent a long time at EPA. And I'm no longer with EPA. (Laughter.) Let me rescue our friend from EPA. The question that you state to EPA is very similar to a couple of examples that I give my students on occasion, which is to say, if somebody wrote a letter to some professor of English at the University of Florida, and we have 6,000 professors on that campus, that does not immediately mean that I, over in the College of Engineering, would know what that letter said. It is equally fair to say that the

Office of Research and Development (ORD), which our friend down here represents, is not necessarily the most influential leverage, if you will, on the development of regulations at EPA. Now, while we would all like to believe that he might be, it's just not the case that it always is, because the laws are not written in a way to allow that to happen. Your congressman and mine write laws that require regulations to be done in 180 days. It's not going to be fair to ask ORD why the regulatory-development people do something that doesn't make sense. It's only fair that I say that in defense of our compatriot from the Office of Research and Development. The regulations are not made with a lot of advance knowledge. (laughter)

**Fagan:**

My question was not meant to be personal in any way.

**Miller:**

I understand that. It's kind of like people tell me on occasion, when I was at EPA, "Oh, the White House called." No, it didn't. Houses don't make telephone calls. And EPA doesn't have an opinion; somebody in EPA has an opinion. And you have to focus on where you're talking about the problem is. And the problem is in the Office of Solid Waste and Emergency Response, the people who make the rules under RCRA. It's not anywhere else. That's where the problem is.

**Carson:**

Let me follow that up, Lamar. We'd like to think we're part of the regulatory process from time to time, and I think what we're trying to do, not only with this meeting but with our studies, is to prepare the information that you need to defend influencing such a regulation. In fact, this work was going on when the regulations were being prepared. So it's just a matter of being in sync with when the regulations are being written, and I think that we influenced the regulations enough so that there was a slight provision for the consideration of what we've been talking about here. But a lot of work's been done since the regulation was written quite some time ago, so part of what we're doing here tonight and what we're going to be doing later in the year is to compile the technical information that will support our position for any future regulations.

**B. Koerner:**

If I can add to that...I think covers of landfills are being driven right now on the basis of subsidence arguments. I think many of the sites that I see, both RCRA and, obviously, Superfund sites, the main concern of regulators and engineers is to assess what will be the settlement profile from the time the cover is put on—total settlements and differential settlements. I think very few people are looking at the amount of liquid to be added for such things as the conference today is addressing. And so I think a certain amount of education as

to the waste degradation is missing in the cover scenario that has been put out by EPA, and the clarification of a year and a half ago. They have mainly been driven on subsidence kinds of arguments. Now, they're related to what we're talking about today—obviously a quick subsidence, like with leachate recycle, or a slow subsidence, but the main driving force in the caps right now and the design of those caps is subsidence.

**Phaneuf:**

Of course, I asked that question when we were looking for an EPA approval of our regulations back during the rulemaking process, and as Lamar pointed out, they came up rushed with the [RCRA Code of Federal Regulations Section] 258 regulations and basically didn't have a good reason why they were so concerned over this bathtub concept when you have a leachate collection removal system that's there and functioning. And I don't think they really understood how to deal with it, where people are going to be monitoring these things, where they're going to be checking for leachate accountability. I think when you see the whole package together, it came across that it worked out that way. Allen Geswein—he was here earlier today, from [EPA's Office of] Solid Waste in Washington, one of the fellows that helped draft the 258 federal regulations that had that requirement in there; and I just kind of nudged him on the way out of the room and said, "Gives you a lot to think about," and he goes, "Yeah, it does." So I think they're [considering] subsequent changes and so forth. We allowed in our regulations, with the leachate accountability being documented, that if you want to defer placement of the final cover, we can do it. There's financial-assurance requirements and other things that have to be looked at. We're by no means saying it's not going to be a hurdle for somebody to do it because we're obligated to [meet or exceed] the minimum federal regulations.

**Panelist:**

I'll just add a little bit of perspective. Okay. I kind of got off the subject, but...One thing about the cap is that there's a certain gas element involved there, too, and if you're going to recover methane from a landfill, then you almost need a cap. And notwithstanding Jerome [Leszkiewicz]'s paper this morning about the moisture content and so forth and when that occurs and how beneficial that moisture is, just putting a cap on doesn't necessarily exclude—I mean, it may, in today's regulatory scene—other ways of getting moisture in, but... That, [it] seems to me, is a battle that kind of needs to be fought in parallel with the cover battle, and I'm not saying that the permeability issue isn't one that's kind of silly and needs to be fought, but...There are reasons for having the cap there that make a certain amount of sense—and get in the way of fighting that battle. Maybe a better battle to fight would be one that allows us to put liquid in the landfill if it serves a benefit to the environment. And the cap is necessary to either recover gas or to help prevent its migration.

**Fahey:**

My name is Bob Fahey, and my company's name is Bioactive Landfill Technologies. And I think that perhaps one of the key points made today was made by Dr. Pohland in his last

presentation with the chart showing that this process of using the landfill as a bioreactor, combined with landfill mining, is the least cost. But I think, from the standpoint of EPA, that the opportunity to inspect that geomembrane after each batch of waste is processed would provide the best assurance that we're protecting the ground water. And I think that's what's going to be the major element about moving into this type of technology. Thank you.

**Robbins:**

Greg Robbins, New York State Department of Environmental Conservation, and I'd like to direct this to Dr. Koerner. I was wondering what your thoughts are on the long-term stability of geonet drainage systems and how they're affected by the heat and pressure of the landfill that's been somewhat developed?

**B. Koerner:**

Okay. The geonets that are being used, for instance, in New York State are basically secondary leachate-collection systems or leak-detection systems. They also have been used in other states for primary leachate collection in landfills. Number one in your question is how they're performing. There is some literature available, primarily a paper that was written on insistence by the Pennsylvania [Department of Environmental Regulation] DER, which looked at the geonet leak-detection system and the flow of 10,000 gallons of water from the upgradient to the downgradient side to the sump. And this experiment was conducted for every lift of waste up to 100 feet high, which was the regulated height of that particular cell. And the flow decreased with time, as one would expect, from just intrusion of the adjacent materials. It worked out fine. That's short-term. The second point you raised is temperature. The temperature of the liner—now hear me, of the liner, not necessarily the waste, but the temperature of the liner—is being monitored in Pennsylvania and in California. The Yolo County Landfill that Don Augenstein is working on has temperature-monitoring on it, and George Koerner is doing a waste-management facility in Pennsylvania. And the temperatures of the liner are far lower than we ever expected. The maximum temperature is 28°C, which is far, far lower than anyone [has quoted recently]—I hear numbers of 40°C, 50°C and, in Germany, 60 and 70 and 80°C, and the temperature of the liner is very, very low [in our studies]. Now, there are probably a couple of things that are happening. Obviously, it's cool under the liner, and so that's a [heat] sink; and also, any heat that's raised, that's being generated, is probably going up in the waste. But certainly, high temperatures of liner systems are not what the situation is seeing right now. And then the third point you mentioned, high landfills—there's a whole new generation of nets coming out right now, the manufacturers are advertising them, and they do not have the rollover effect that we see at approximately 150-foot-high landfills and things like that. So the industry is responding to megafills and very high landfills. I think geonets are for real. Within certain constraints, obviously.

**Robbins:**

Thank you.

---

**Guilfoy:**

My name is Mike Guilfoy. I'm with the New Hampshire Department of Environmental Services. Before I ask my specific question, I'd like to share with this gentleman here who asked about how he could sell this to his client by telling you what our experience has been in New Hampshire with leachate recirculation. The landfills that were recirculated, the reason they were doing this is because they were saving quite a bit of money by recirculating. These landfills were in [remote] areas where if they weren't recirculating, they would have to truck the leachate considerable distances to get to a treatment plant. And so it was a lot cheaper for them to recirculate as much as they could back into the landfill and only truck off what they had to. Another thing that we're seeing quite often is that owners and operators want to try to limit their long-term liability. And once a landfill is capped, the owner/operator still owns it. You know, our regulations say it has to be monitored for 30 years, but if the landfill is a problem or is potentially a problem, you know, that's not a timeframe that's set in stone. Our regulations say that when you demonstrate that your landfill has effectively stopped producing leachate, then you can get out of that rule. And so a way to do that, people are realizing, is through recirculation. And I think those two factors really are, at least in New Hampshire, what drove the push toward leachate recirculation that we saw over the last couple of years. Now for my specific question, and I'll just throw it open to whoever. And this is just a practical operational question. In a typical municipal solid-waste stream where a lot of the waste is bagged, and let's say that the waste isn't shredded, would leachate recirculation not work in that situation where the bags are just thrown in and compacted over? And the bags do get broken somewhat as they're driven over, but they're essentially still intact. Is shredding absolutely necessary for this?

**Pacey:**

I'll take a shot at that. John Pacey. Shredding is normally not practiced because that adds tremendous costs. What we might call flailing or trying to break it down by placing refuse in thin lifts, having equipment come along with the treads that would break it up or chew it up pushing it uphill, for instance, running a crawler across it, or the compactors that have the [rippers] or the spike-type things. Try to break down the refuse, don't put in 5-foot lifts or 8-foot lifts. Spread it in 1-, 2-foot lifts, and try to make an effort of breaking it down. You can still recirculate in where you have the bags; it's just not as effective. You're missing a lot of it.

**Miller:**

John's quite right. It's not usually the practice to shred. I had this discussion at dinner tonight. Why should we shred? It costs a lot of money, and it's a lot of trouble, and it's a maintenance problem. And all of that's true, but if you're ever going to do anything with the material, like try to reclaim it, you're going to have to process it anyway. You're either going to process it upfront or at the end. You take your choice. It will work if you put it in small lifts—we do, at Alachua County [Florida]. We are getting good degradation results—in fact, better than most people on this panel thought we would be getting, including me, at this stage. So, it works without shredding; I just think it would be better if you did. At least to open the bags, and when I'm talking about shredding, and I think you probably should define

that—a lot of people talk of, you know, half-inch pieces of material or something. I'm just talking about opening bags and, say, you know, 12-inch pieces, 6-inch pieces, or whatever, just breaking things up. Not tearing it up into little small pieces. I don't think that makes a significant difference, but getting those bags open does.

**Leszkiewicz:**

I'll just add to this. If you recall the slide that I put up of the municipal solid waste in Ottawa, Canada, you saw a very high percentage of waste coming out of the packer trucks. It was in plastic trash bags. Their process of operating the landfill—they place, as I said, an 8-foot lift, it's a daily lift. They spread that in no more than 2-foot-thick loose thicknesses when it's pushed out. They run over it with a compactor with a ribbed drumwheel with about 6- to 8-inch-deep ribs in the drums. Not pleated drums, which will stab the bag and then the bag will just hang on the cleat and run with it—this tends to tear the bags. And operating with that thin a spread lift as they do and making four to six passes, they went back in, excavated, and checked themselves, and they were getting about an 85-percent bag breakage rate, which was pretty good. So, they didn't get them all but they got a high percentage of them where they tore them open enough that water would get in and out in the process of being subsequently covered in the landfill. So you can get a high degree of breakage, but it takes [care] in the operation. If you are operating and pushing 4 feet of waste out in front of you and running over it two times to get your compaction, you're not going to get the bag breakage.

**Harrison:**

My name is Steve Harrison. I'm with a regional landfill company in Washington State. And my question is regarding systems that will actually work, actually operate on a full scale. The industry is generally going to these huge regional landfills like ours, and it seems that getting the liquid in the landfill effectively is a huge obstacle we haven't overcome. I thought that by adding wastewater at the working face and bringing it up to maybe slightly above field capacity, we'd be ahead of the game, and here I'm learning that will only work for a short time, and eventually it will—shortly after we put the cap on—it may dry out. I don't see a system, at least at this large scale, of injecting water that's going to work, or at least I haven't heard anybody say they have a large injection system that wets 60 percent or 80 percent of the waste. It's a very difficult mass of material to wet uniformly, especially with the larger landfills. And on top of that, the other systems that have to go in the injection pipes themselves or the gas-collection lines, et cetera, they're going to be in a very aggressive environment when this large landfill begins to settle on a big scale. And I just wonder what anybody's level of confidence is that we're going to come up with reasonably cost-effective systems to actually make this work on a big scale. Thanks.



**Miller:**

I don't have any problem believing that the system that we're using at Alachua County is working and that we are, in fact, wetting better than 80 percent of the area that we're trying to wet. I would also say that if you're interested in achieving the highest possible rate of wetting and the shortest period of time for decomposition, that we would do some things differently. The ponds that we used to start with worked extremely well, but they have certain drawbacks, and everybody, I think, probably understands problems with ponds. One is, rainfall falls in, so you gain about as much as you lose. And other things, like, they smell, and you have gas evolution, and people see them, and just seeing them, there's a perception that there's a problem, if you see gas bubbling up. They're not really as bad as a lot of people imagine they are, and they work, but the horizontal-injection system is also working. It's not as fast, it's going to take longer to get the area saturated, and it's going to take some playing with it to determine what the pressures need to be on the injection and the rates of injection. But I don't see any problem thinking that it works.

**Harrison:**

What diameter and how long are these injection [laterals]?

**Miller:**

We have 3-inch pipes and we have 4-inch pipes, and they run from 400 feet to 800 feet in length. They run down the side slope and have a 120-degree angle going out into the landfill. We have not lost but one out of 18, and that one was lost because a compactor went wild and the operator forgot where the pipe was. We haven't had any problems, and that was on installation, that was before we used it. It wasn't because of subsidence or settlement or anything. We haven't lost any pipes for clogging or for subsidence breakage, and we're using [polyvinyl chloride] PVC type. And most of it was not even Schedule-80 type. I don't see that it's the huge problem that people imagine it to be.

**Harrison:**

Right, well, that sounds hopeful. I assume you have a sandy site up there in Alachua County?

**Miller:**

Oh, extremely sandy. Like beach sand.

**Fagan:**

So what do you do where you've got [low] permeability of the sand? What type of [permeability] future do you expect?

---

**B. Koerner:**

Dennis, Fred Pohland and a student of his have an EPA report out on all the alternative daily cover materials, and I think we should all look at these different options and really be concerned about the hydraulic barrier that low-permeability soil will give at every lift. And in my mind that's the real killer of the movement of leachate through the system. And that requires regulatory assessment as to what is the technical equivalency of one of these myriad of different alternative daily cover materials with 6 inches of soil. So the regulators really have to work with the engineering community in this regard.

**Pacey:**

I think a couple of other points should be made in reference to your question. Number one is, Jerry gave us some figures today on his estimates. I'm not sure that there would be agreement with Jerry Leszkiewicz's percentages, values?

**Leszkiewicz:**

They're ballpark, intended to basically make a point. Certainly, we don't have enough data to carry it out to decimal points or what have you. So I agree with that, but I think the concept is there.

**Pacey:**

Right. And the second thing is, as far as large-scale applications like you're inquiring about, it's been one of the more difficult things that we in the industry have to [do], is to point to examples. There just hasn't been a lot done [with well-monitored] projects. We've now got, what, about three or four [monitored] demonstration projects that are large scale? You've got some projects, other people have, but you're talking about a massive project. You've got a major landfill up there, and you're going to have to do some experimentation. And what you're going to have to do is get some guidance just to help you, and then you're going to try things.

**Harrison:**

Right, well, I know that, and we're really enthusiastic about it, but I wouldn't get too excited right now about the quantities you've heard because it may or may not be correct. And as I look at these—for instance, the Mountain View [project], which wasn't, obviously, near the scale that you're talking about, nor are any of those—once that was set up, and we had the moisture in there, we didn't have a problem, but we had some infiltration going on over time. You only have, what, 6 inches of rainfall a year up there?

**Fagan:**

Yes, 6.5, it's in that range.

**Pacey:**

So you've got evaporation taking care of most of what you get. So you've got to really go out and get your excess water and bring it in, and you've got that, from what I understand. So your problems are a little bit different. You may take an area at a time as opposed to trying to take the whole mass. And you're phasing, in other words, and you may be able to handle that fine, and you're just...People in the business have got the opportunity to work with things and try something new the next time. And you've got a big enough landfill, I think, to work in phases and develop a managing technique.

**Fagan:**

Are you allowed two questions? (Laughter.) I recently retired as Solid Waste Director of [a county in] Florida, and we recirculated our leachate simply by taking a [backhoe] on top of the fill, digging down as deep as we can, and filling the excavation with tire chips. Then we pumped from the bottom of the cell into the trough that's filled with tire chips. And I think this would probably work whether you have sand or heavy clay. But I would like to make a comment or ask a question of the panel. Back in 1979, when I took the position as Solid Waste Director for [a Florida] County, we had 98 inches of rain that year. And over the years, in trying to foresee what might happen, in 1986 or 1987, I investigated the cost of a packaged leachate treatment, and the price tag was \$2 million. So I checked with the folks that manufacture rain enclosures, the air-supported structures, and for the same price I could get that. So I wondered, if we do put an air-supported structure over the cell while we're in the process of filling it, that would prevent the precipitation from even touching it, then we don't have anything to clean up. And the capital cost was the same.

**Panelist:**

I think your system is a special issue. They had a permit that you couldn't build a new landfill or section within 1,500 feet of where the public had access to it, or something like that. And so that came down to an air-supported structure, and it was a double-entry, and you had to go through the air-lock. And so if the system works, it is built to withstand pretty high winds.

**Harrison:**

But also, you don't have any seagulls, you don't have any blowing paper....

**Panelist:**

But that's also a temporary fix. There comes a point in time where you're done.

**Harrison:**

Not when you're [experiencing] a rainfall [of] 60-some inches.

**Panelist:**

But that structure is going to go away when you're finished with the landfill. Now you've got to—

**Harrison:**

No. It's set up so that you develop it for a single cell—

**Panelist:**

Right.

**Harrison:**

And each cell is identical...

**Panelist:**

So you can move them, yeah.

**Harrison:**

...so you move it from one cell to the next.

**Panelist:**

Right.

**Harrison:**

And the size I was talking about was \$2 million. It was 1,100 feet long and 600 feet wide, and the height of our cell was 95 feet, so it was up about 125 feet. And it was a controlled environment.

**Panelist:**

Now, you've got the emission issue, as well.

**Harrison:**

Yeah.

**Panelist:**

'Cause you've got to have a fair amount of generation.

**Harrison:**

...but as the air comes in from fans at one end, you begin your filling at the other end with exhaust, so that you're working always in the fresh air that's coming in at one end.

**Panelist:**

Okay. You know, it's another concept to take a look at, but when you finish that, again, you've got the dry waste. That's okay 'cause you're trying to get away from leachate treatment. Well, that's why we [introduce] only the amount necessary to make this thing comfortable, the reaction.

**Harrison:**

Well, I think that's the whole concept behind bioreactor technology, anyhow, is to be able to control and throttle the process and make it do what you want it and need it to do. Because right now, we're still in the stage where we're just basically lighting a match and throwing it at it and watching to see what happens, okay? We're getting better, and we're learning more, and we're getting to a point where we can start to effect some control, but when we get to that point where we can actually do that, then we've got the system to where it's marketable.

**Panelist:**

I'd like to point out that the people who are studying the [polychlorinated biphenyls] PCBs in the soil have found out, by adding phosphate they get a much more rapid degradation. Now, wouldn't phosphate increase your—there must be a shortage of phosphate in the stuff as you get it.

**Pohland:**

I guess I should answer that one. First of all, the soil systems are aerobic systems, usually, and they're going to behave a little differently insofar as their ability to break down PCBs. But should they be able to be broken down in anaerobic systems, such as a landfill, there's a sufficiency of phosphorus in the landfill, although it's not expressed in the leachate. It's actually there in a kind of a precipitated way but in reach of the biology that might need to use it. So it's in equilibrium with the liquid phase and in sufficient quality to allow for usual biological activity. But at the surface of the sediments, it's aerobic. So some people say that you ought to cap the Hudson River (laughter) and leave it in place down there at the bottom rather than stirring it up. So they're actually thinking about ways of actually stabilizing the sediments, so they won't be disturbed.

**Bartles:**

My name is Don Bartles, Columbia County Solid Waste Management in Georgia. Is there a placement density that—where you could enjoy the benefits of recirculation moving through that waste mass while at the same time, structurally tie them as you're building? Where you wouldn't want to spend the energy to go high up in placement density and restrict that flow, nor do you want to continue to build structurally on top of it? Is there any number that's come up to the panel that would represent a good placement density to facilitate this operation? Waste-placement density?

**Campbell:**

Let me just make a comment. I don't really have an answer for the local situation, but if you're going to have relatively moist landfills because you're going to have active recirculation, and they're going to be relatively deep—and by that I would probably mean 10, 15 meters, 30 feet, more—my reaction would be that you would get a fairly uniform and fairly tight settlement of that and high density of that waste just naturally. And it doesn't matter what you've compacted it to as dry waste. People relax once the machine's gone, and it's very dry anyway, and it'll be at this—whatever the density is that we can use for household waste. Use my words advisedly, not municipal sort of waste, household waste. We've done a lot of work on measuring this in cells and by excavation, that with wet waste the dry-weight density—and I use that word advisedly—is about 0.8. And that is about the best you're going to get. Wet weight is about 0.95—tons per cubic meter, I'm talking about. Sorry, I don't know what we are in British units. (Laughter.)

**Bartles:**

I appreciate that, but what I was after is once you tip the waste on the operating face and you want to run a compactor over it. Once we get to our capacity, we can't come back there again, so we're trying to place as much waste in that cubic yard as possible, and we'll buy as big a piece of equipment as will let us do that. But it seems to me, though, that maybe this process, this bioreactor, is going to accomplish that volume that we're after in energy production on that waste, through volume reduction, through degrading. And rather than invest that energy and money into compaction with that piece of equipment, what is that waste, pounds per cubic yard, is going to allow you to still do recirculation and at the same time keep you feeling structurally sound where you can build on top of it? If that number happens to be in—I was going by this gentleman here, I think it was 1,150, I believe it was the term you used in your presentation—that's great, that would allow us to keep the same compaction equipment we have and still enjoy more volume. I reckon I was trying to find some comfort in believing that. (Laughter.)

**Miller:**

As I said, I'm probably the least qualified to actually answer it, but I'm also among the least hesitant to just give you my opinion. (Laughter.) I've been trying to convince the director of public works for our county that we ought to quit buying compactors. They don't do any good. All you want to do is spread it out if you've got it broken up and if you're going to run it wet. But if you do, then you don't need all of that heavy energy that you're putting into it because gravity will give it to you as settlement takes place.

**Bartles:**

I appreciate that. And if you would allow just one more question—and I understand the purpose of this session was the anaerobic-bioreactor concept, but is there anything that would prevent EPA or those 47 other—or 43 other—states that wouldn't entertain an aerobic bioreactor? The emphasis is bioreaction in that landfill, rather than just a particular approach, anaerobic or aerobic?

**Panelist:**

Uh-uh, the emphasis was on liquid recirculation. It's the liquids that they're concerned about. It's the controlled liquids, the bathtub, the seepage.

**Bartles:**

I was thinking more in an anaerobic—taking that waste mass and doing the same thing [the panelists] are talking about but using it in an aerobic state versus anaerobic state. And not to debate it at this point, is just as long as EPA is receptive to—it's the bioreactor that you're receptive to, not necessarily the methodology to get that. That's all I was after.

**Panelist:**

I guess I would disagree with that, just from a practical standpoint and also the economic standpoint. If you can imagine a 100-foot-deep landfill, the difficulty it might take to maintain aerobic conditions in that landfill, to aerobically oxidize everything that could be oxidized—it would be a tremendous task. Much more than recycling leachate and pulling gas. So the costs are probably several orders of magnitude above what you would do anaerobically. Anaerobically is very cheap, and furthermore you get a rebate, so to speak, in terms of the energy values of the gas.

**Panelist:**

I think if you ask some of the people here who tried to put the fires out on sites (laughter) where they have overpumped them—moving gas and got air in them—and taken a year trying to put them out. The last thing you should try and do is run these big masses of waste aerobic. Personally, I think you court disaster.

**Panelist:**

That's really the issue 'cause the tendency is for them to want to go anaerobic, and the tendency that the operator has is to try to pull more air through it to keep it from doing that, and then you get localized hot spots, and it just takes off, and you get a fire, and you've got a real problem.

**Bartles:**

I understand. Thank you, gentlemen.

**Phaneuf:**

Just to address that one issue, not to debate the aerobic versus anaerobic, but I think the question was whether or not the regulatory agencies had an issue or concern with that. I think from a federal regulation—and correct me if I'm wrong, Dave or Dennis, if you're aware, too—with respect to the federal regulations, they don't really get into the landfill operation and into the detail [of this]. Nor do the New York State's regulations really get into that to a large degree. The City of Albany Landfill—Dave Hansen, I know, is in the back there, the operation of that facility—Dave, isn't it true that that facility, the concept that you did under that research project was basically operation of that facility aerobically? And then turning it over anaerobic at the end?



**Hansen:**

Yes, well, what we did there—we have the advantage of shredded garbage because there was a preexisting shredding plant. So, shredding is expensive, and not everybody can do it, but it's marvelous, marvelous stuff to work with. It's real nice to work with shredded garbage. But we wetted and shredded the upper 10 feet only, kept it loose, and in one word, the reason you'd do this aerobic pretreatment is air space. Because if you let it cook aerobically, just the top skin, I agree.

I'm afraid of fires. I'd have that whole landfill aerobic today, only I'm afraid of catching it on fire, so we're not doing that. But the upper skin, we kept aerobic for about 30 to 60 days, and then when you compacted it with your standard landfill compactor, you'd get very high effective density—it's not a physical density, as John [Pacey] and I had an interesting discussion about the specific gravity of garbage, and I came into agreeing with him that it rarely exceeds 1.0 for U.S. garbage. But the effect of the loss of mass and so forth in the aerobic scene, you get the easy-to-take organics real quickly. This so-called aerobic retrieval, it's just the top skin was aerobic, not the whole waste mass. But the owner of the landfill, the City of Albany, found, through repeated surveys of independent engineers and so forth, that they were getting much better effective density and that it was cost-effective. So the reason you would consider something like that is that it can be cost-effective in terms of the air-space savings. And as someone pointed out, maybe 20 years from now, the landfill would have settled, anyway, but that's of no economic consequence to the owner. The owner's interested in this year and next year.

**Phaneuf:**

Excuse me, David, if we could just pursue that because I was just wondering. As I understand it, you do that skin, then you come on, and you turn it anaerobic, then you add a new skin, and essentially you're building up an aerobic [system], which you turn into anaerobic, then add another aerobic, and—

**Hansen:**

Right. These aerobic layers were just the top working lift to the garbage. In other words, it was just layered up as it went up. And as soon as we ran over it with a compactor, then it would just be let go anaerobic. The problem—that's the reason we came up with this sprayed-on thing, is, you have to leave it loose at first. You can't compact it day one or you'll be unable to distribute the air evenly. But you compact it on day 30 or day 60, however long you have, you sacrifice the pipes. And we use thin-wall [corrugated polyethylene] pipes, not expensive pipes, the cheap highway-drainage pipes. And you have to cover it—we have to cover it every day. You can't have these big masses of rotting garbage uncovered. So we would spray on this gunnite-like material that we call Posishell. So that's what occurred in Albany.

**Phaneuf:**

And we had issued a research permit to Dave to operate the facility because it was 180 degrees from a conventional landfill operation. It was aerobically digesting the first waste to be put in at the earlier stages, but it was so different we weren't sure of how it was going to go. But we regulated it, permitted it, through issuance of a research trial aspect. So it was permitted.

**Wulf:**

My name is Steve Wulf. I am Solid Waste Director for Kootenai County, Idaho. I'd just like to make a comment. We initially looked at a recirculating landfill 2 years ago, and the reason being is that we had such a long haul for leachate to get it to a POTW. Dr. Pohland earlier said that the operator training is very important with these sorts of systems, and I felt, for the last year I've had a tiger by the tail. Our gas generation was a lot faster than what we were used to. We originally were in a dry-type of landfill environment, and once you went anaerobic the neighbors knew it, and we weren't prepared. The question I have for the Doctor: Have you reviewed any operations manuals for these sort of landfills that might help me develop some procedures that would prevent these problems from happening in the future?

**Pohland:**

That's an easy question. There are none. (Laughter.) But, I think in the gradual evolution of the technology, that this will come hand-in-hand. It must because you no longer have the luxury of time on your side. Because as you say, things can happen very rapidly. And the worst thing, it's not so much the gas production, provided you have some kind of way of managing the gas. But the worst thing that can happen to you, if the whole thing becomes acid and you inhibit the conversion of the acids and the intermediate products to gas. And once that process starts and if you don't control your leachate recycle appropriately, you can continue to saturate more and more of the area with acids and end up with what we used to call "stuck digester" in sludge digestion. So that's why I think you can't create a bioreactor technology without a bioreactor mentality going hand-in-hand with it.

**Warram:**

Good evening. My name is Jim Warram. I'm with the Oklahoma Department of Environmental Quality. My question is directed to Jeff [Harris] since he's an operator and to Robert [Phaneuf] because he's a fellow regulator, but I'd be interested to hear other people's opinions on this. If a landfill is going to decide to be a bioreactor, can—as a regulator, can we look at not requiring them to bulk their liquids and semisolids as required by current regulations? Landfills are not allowed to put in both liquids and semisolids wastes, but if you're going to be a bioreactor, that regulation seems to be counterproductive for what you want. Which would be good for an operator because then they're not filling up their space

with this type of bulky material and they're getting the extra liquid. So I'm curious to hear people's comments on that.

**Miller:**

I don't really care what these other people think about it, but I'm going to tell you what the law says about it. That's a criminal violation, and you can get put in jail for that. (Laughter.) Now, they can tell you what their opinion is about the value of the regulation (laughter), but that's what the regulation says, and EPA has done it.

**Warram:**

Well, I understand it's regulations, but...

**Miller:**

You can't just decide a regulation is not good [and choose not to] follow it.

**Warram:**

Well, I'm not proposing that. I'm just saying, if a facility [operates as a] bioreactor, the regulations [are unclear].

**Phaneuf:**

That's correct, and we have a variance procedure on our regulations. Obviously, if you're going to be recirculating leachate, then that would be the regulatory mechanism to do it, that they get the proper variances and so forth that you need.

**Panelist:**

There is a regulatory requirement. Again, that's a variable thing. The other thing is looking at the operations aspect of that facility. Are you going to start operating this landfill as a service empowerment versus a landfill? So that's an aspect.

**Leszkiewicz:**

We're again, still, at the front end of the development technology. The purpose is to learn how to control that technology and make it do what you want it to do, what you need to have done, in your landfill application. The goal down the road here is to better understand and define the water-balance requirement so we know how much water we need, how much

leachate to recirculate, if we need makeup water, how much, and when to put it in. After we have a better understanding of all that, then we can start looking at, how do we meet that, what ways are there of obtaining these sources of water? And we can start addressing whether or not changing the regulations in certain areas would be of advantage to accomplishing our overall goals. So you've asked the right question, you just asked it too soon.

**Miller:**

I have a comment on that. The language, it's 40 [Code of Federal Regulations] CFR Part 2, 5828. The language specifically bans liquid wastes, okay? It doesn't ban liquids, it bans liquid wastes. And I have been talking ostensibly with people within EPA, about this, and [liquid] wastes are banned, liquid amendments may not be, and I think that's very important for everybody, considering [this operational technique]. And I tried to get more definitive rulings on this but have found that there are quite a few obstacles. At the present time, the question is open, but I think there is definitely the possibility that liquid amendments may be possible, in addition to what is specially permitted in the law. And the law specifically permits the reintroduction of collected leachate to [RCRA Subtitle D] landfills and also the reintroduction of leachate, which is one of the things that would help improve the situation that Jerry Leszkiewicz was talking about. So that's where things are at the present time.

**Panelist:**

And I'd like to correct myself, too, with respect to that. From a bulk-liquid perspective, the gentleman down there is right. I was looking at it from the standpoint of the wet sludge, the sludge that was coming in maybe wet and not quite 20-percent solid. Bulk liquids are handled through wastewater-treatment facilities, and again, a landfill isn't a wastewater-treatment facility. So with that aspect of it, liquid waste should go to wastewater-treatment facilities, and we'd encourage that. Wet sludges, on the other hand, we can deal with that.

**DeHavilland:**

My name is Annette DeHavilland. I'm another regulator from the state of Ohio, the Ohio EPA, and we are one of the 47 states that—our rules are silent as to leachate recirculation. And we are looking at changing our rules to address leachate recirculation. Personally, I am not concerned about how to tell people how to do it; I want to tell people what not to do. And I'd like to have some help as to what would be unacceptable, excessive behavior for leachate recirculation. Bioreactor landfills, for example—how much liquid injection could be too much liquid injection? Any suggestions? (Laughter.)

**Pohland:**

Your number one is very easy. You tell them that they cannot exceed 1 foot of head over the liner. That's very simple.

**DeHavilland:**

How do you monitor that? (Laughter.)

**Panelist:**

The key, I think, that a lot of us would like to see, and we criticize EPA for this all the time, is to go with performance requirements as opposed to prescriptive. You have professionals that are going to be designing these systems. Hopefully, they're registered, they're trained to do these things, hopefully, qualified. And if you give them performance criteria, they know what they've got to meet. Now, the issue we sometimes see is where it's hard for, I think, some people to believe that anybody can design something adequately. And so then they get into prescriptive techniques, such as the 1 foot of—well, the 1 foot is a performance criterion.

**Miller:**

Again, you know, I can't really comment on the local situation, but I would have thought there ought to be some restriction on how close to the boundaries, particularly of mounded sites, that you are able to put this liquid waste in, or liquid returns. He was saying how close you should get to the edge. And I'm just reminded of a very aptly named site called Junk Bay in Hong Kong, part of which fell into the sea about 5 years ago because they've got slippage, and it came out the side and the whole lot just went. And I'm absolutely sure there should be some restriction on the distance from the edges of these mounded sites, but what it should be, I'm not an engineer, I wouldn't know.

**Reinhart:**

Yes. That was the point I was going to make, that this is a hydraulic system, you do have to look at the rate that water can move through the system, and I think this is the kind of data that we're starting to gather. Obviously, if you put in too much water too fast you're going to get ponding, surface ponding. If that's a restriction, that's what you have to look at. So I think we are gathering data on how fast the water's going to move through. And if you're putting too much water and not promoting the right reactions, that's another consideration.

**Leszkiewicz:**

You have that one extreme. If you put too much water in or recirculate too much too fast, you can get a runaway biological reaction you may not be ready to, or have the proper gas-control systems in, to deal with. So that's one end of the spectrum. On the other hand, if you don't put enough liquid in, you may eventually start to dehydrate the waste, and the whole process may start to come to a halt. We don't know where the numbers are yet in that range to effectively address your question, but I think the goal here is, ultimately, to learn the

characteristics and properties affecting this whole bioreactor system and how much water is needed to accomplish what.

**Campbell:**

There is data on the hydraulic conductivity of water through waste, and you can do it by pumping [to] saturated levels and lowering the level and, basically, looking at the water movement. And I know in Europe there's quite a lot, in the U.K. there's quite a lot, of data on hydraulic conductivity. Whether it's relevant to the near-surface as opposed to in-depth, of course, is another matter.

**Pacey:**

I think if you're going to be trying to regulate this without having all of the data in, you're courting the same kinds of problems that we frequently criticize state regulatory agencies and EPA for developing rules before the data's [available]. But if you decide to do that, you should stay away from prescriptive regulations, like the problem we're talking about is having them be at some minimum distance in from the edge of the landfill to prevent seeps out the side of the landfill and rates of recirculation. Given that what you want to do is to prevent seeps, you don't care how close they are to the edge, it depends on how they prepare that edge. And it depends on whether it's covered and whether there's collection and all the rest of it. Don't try to give technical prescriptive numbers to it but give performance standards—"don't release any leachate outside the bounds of this cell," or whatever.

**R. Koerner:**

I'd like to agree with that recommendation. I think it's very important to leave the flexibility to the designer of how to meet that type of a performance requirement. Don't be prescriptive and say—arbitrarily say, 40 feet or 50 feet—'cause there are methods of designing around that. As an example, typically and operationally, what we can do is, before you get to the edge of a landfill you can dig a trench right at the edge to facilitate the drainage from one layer down to the next layer below it. So I would prefer that you leave that up to the designer. And the goal is to control. Let him figure out how to provide that control.

**Panelist:**

They had these trenches in the Hong Kong landfills, and you get 13 inches of rain in about 6 hours, and that'll soon muck it up. (Laughter.) And that's what happened. I mean, they have real problems with water out there, and when you've got a tremendous surface runoff and it's all getting poured from that edge of that landfill—well, just wait!

**Pacey:**

Happens in California all the time, now.

**Questioner:**

One, I think, very interesting example is the Clean Air Act that has been going through now for about 4 or 5 years and got another 5 years to go, I guess. But not soon after it was issued in draft form, the state of Texas adopted many of the draft criteria. And EPA got very upset with that 'cause they've changed two or three times some of the, if you will, prescriptive and performance criteria. So, you get out there too far in front of what's going to—most people are looking at in more details than you are. That's something that was pointed out here: we're still trying to understand everything, and you don't see all the answers here tonight.

**Leszkiewicz:**

I think the best thing that you and the other 46 states can do at this point in time is open the door and encourage research and development of this technology in your state. And that will allow more people to begin to experiment, to contribute to the base of data, and to help us more rapidly get to a point of maybe being able to understand how to do what we want to be able to do.

**DeHavilland:**

Thank you very much.

**Campbell:**

Can I ask Stephen [Harper] a topical question? In your presentation, I may have missed something right at the beginning. I didn't hear what the rationale was for why you had to provide these protection barriers. What was the evidence, if any, of any offsite ground-water contamination or, even worse, pollution? Or was there none, and was it just a regulation? Because that seems to me a rather pointless exercise. If there isn't any cause of pollution, it would seem to me there was ample opportunity for very successful ground-water dilution running through the base of that site that probably wouldn't have caused any pollution. So what was the necessity for what you were doing?

**Harper:**

Well, there was ground-water and surface-water pollution. And here in the United States, we have a thing called a risk assessment in which you take the concentrations of the various contaminants and you use a reference dose and an average person's body weight of 70 kilograms and assume that they're going to eat the soil or drink the water for 70 years. If

---

they do that and one person out of a million gets cancer, then that's unacceptable. (Laughter.) And that was basically the case.

**Campbell:**

But I can understand that for a new site where you can't necessarily easily predict what might happen. But this is an existing site that, I assume, has been monitored or could have been monitored for 5 years beforehand and has a lot of data. Was there gross ground-water pollution?

**Harper:**

Well, I wouldn't call it "gross" (laughter), but it exceeded the risk criteria, and so that's enough to put it in a regulatory circumstance where some action has to be taken. The immediacy of that action isn't always that obvious.

**Campbell:**

And that risk—it still seemed worth it, even if you have to spend however many million dollars it was to [remediate]?

**Harper:**

I can't answer that question.

**Carson:**

Let me add a bit to that, Steve. In that particular case, the city was trying to be proactive, they were going to try to do something in advance of being forced to do something, at which point the cost tends to run away from you. That was the first case. The second part was that this particular location is next to a creek that is one of the largest Corps-of-Engineers cleanup projects in the country. So they realized they were in a sensitive situation politically and also wanted to do something about it, again, proactively.

**Miller:**

Just to have a comment there because it probably applies to some of the audience on various occasions, but our visitor from Great Britain has asked the basis of our system of government (laughter), which is what he's basically done.



**Campbell:**

I'm glad you've got one 'cause we haven't. (Laughter.)

**Miller:**

We in this country have a government of laws and not of men or of opinions. It's not really terribly important what your opinion is, for a man, or EPA's; the Congress tells EPA what they shall write regulations on and how they shall do it. And if EPA differs from the road that the Congress planned, the federal courts hand it back to them. Every time. So, you know, it's not a question of whether it's worth it or not; it's because the Congress said "Do it." And they represent the people. So it's not an opinion question, it's a statement of—they were ordered to issue the rules. [Ben] Franklin was right years ago when he said—and Mr. Churchill was even more right when he came over here and said, "Democracy as it is practiced in the United States is no damn good, but it just happens to be the best form of government so far devised by the mind of man."

**Guilfooy:**

Mike Guilfooy again. This is a design question, so I'll throw it out to whomever wants to field it. Given that you are restricted to 12 inches of head on the liner and there is quite a potential for needing to get a lot of water off that liner very quickly when you're doing leachate recirculation, what kind of rules of thumb do you have for sizing offliner storage for leachate? Is there a multiple of help with the quantities you're going to be recirculating or something that's tied to the size of the facility? Our experience with this has been that no matter what size tank you put in there, it's not enough. (Laughter.)

**Panelist:**

Sizing a tank off the liner which can temporarily store the leachate before you're going to either have to truck it off or recirculate it back up.

**Phaneuf:**

That's a point of controversy, but we did try to tackle that problem in our regulations, and it's still, even though we've got it in the regulations, we look for the amount of landfill that's being built for assessing and doing more-or-less a health-model analysis for that landfill. During an early stage of operation, very little waste is in it, and understanding that, we only build our facilities in phases in New York State and as, I think, throughout most of the country. And what we see typically being built is in the order of, maybe, 5 to 8 acres at a time. That cell there, we looked for 3 months' worth of key flow storage capacity. In other words, the 3 months are what your high flow would be. We looked for that in upstate New York and the Northeast, and this would be different where you're geographically in. We looked for 3 months' worth of storage capacity with some reason. What operators have told

me, because actually that's not enough, but we've seen facilities with at least—if it's 700,000 gallons per acre [or] 700,000 gallons' worth of storage capacity, in that vicinity. That's a manageable amount. Once a tank is full, it's full. So watch your ability to keep that head down and keep up with your leachate production. It doesn't matter if you've got 100,000 gallons of capacity or a million gallons of capacity. Once the tanks are full, you're in trouble. So it's a management aspect.

**Guilfoy:**

Have those regulations been in effect long enough? Had there been facilities built that have been operating long enough so that you can tell whether or not that works?

**Phaneuf:**

Yes, and—and it's a good rule of thumb. And you can add to that, the operators say the same thing that Lamar [Miller] and that you said, that it still wasn't good enough.

**Reinhart:**

I collected some data from operating leachate-recirculating landfills, and I plotted the amount of leachate that was taken off site for treatment versus the amount of storage that was provided. And there was a definite relationship there. The more storage, obviously, the less—the wider the spot in the line, I guess, and the less leachate that had to be taken off site. And I cannot remember that exact number, but it did agree with what the German study on—they had 13 full-scale leachate-recirculating plants, and they came up with a — recommendation on size of leachate, and it was—I think it was something like 10,000 gallons per acre or something of that nature. But, I can give you that kind of information if you come and talk to me. But, you know, it's a lot.

**Miller:**

I would say that if we went by the New York [requirement]—I guess it's a requirement, I started to say "guideline" but it's a requirement, isn't it?—we would have five times more storage than we have. What we did in order to make up for that—because we have 360,000 gallons; if we took the 90 days that he's talking about from our average flow, we'd have to have 1.8 million gallons. So we would have to have five times as much as we now have. What we, in effect, did was to build those ponds, 12 feet deep and 1.3 acres up on top of the landfill, and we stored 3 or 4 million gallons in the ponds.

**Guilfoy:**

Are you anywhere near residences, though? Didn't that cause a real bad odor problem?

**Miller:**

No, I really don't know the answer of how far we are from the nearest residence, but it's at least a mile.

**Guilfoy:**

Oh, okay.

**Miller:**

Close to that, anyway, for the nearest residence. We do have some farming operations closer than that but not residences. And we didn't have any terrible odor problem, anyway.

**Guilfoy:**

And you didn't get any complaints from that?

**Miller:**

No, I can't say that. We did get some complaints. The County Commission got a phone call once a week whether we had odor or not. It's independent of the odor. It's a perception problem.

**Guilfoy:**

Yeah.

**Miller:**

And you are going to get some complaints.

**Carson:**

Lamar, you wouldn't suggest that the surface ponds are the best reintroduction technique to practice right now, though, would you?

**Miller:**

I don't think any of us really like the ponds, and they've all got some disadvantages like odor problems and perception and the rest of it, but they do work. They work very, very well. And if speed and percent of complete saturation is what you're interested in, it's hard to beat that pond.

**Harper:**

I guess I would answer your question with a question, and it kind of relates to what Lamar [Miller] is saying. And the question would be, are you sure your pumps are big enough? Because it takes that water a pretty good time to work its way from the top of the landfill or wherever you put it in back to the liner. We talked about the permeability of refuse, which varies over a couple of orders of magnitude, but basically it's pretty low. And Lamar [Miller] is talking about taking the water and pumping it back up into his recirculation system, and I was going to suggest the same thing. The vertical wells that you put in and the horizontal wells that you put in, if they're empty, have a significant storage volume. And what you have to do is be able to pump the water back out there fast enough to get it back in the well before it comes back at you. And so if you're pumping for certain amounts of time and then you're not pumping for other amounts of time, then obviously, you have some additional storage capacity in your leachate recirculation system. Lamar uses ponds, but I think that the wells that you have serve a significant purpose in that regard, too. So if you're designing one, I guess what I'm saying is, make sure that you think carefully about your pump sizes in order to give you that extra storage capacity.

**Guilfoy:**

Yeah, I agree with that. But the big problem that I have seen is that we don't allow—in the projects that we had, we didn't allow them to recirculate if there were 12 inches of head on the liner. They'd have to get that head off.

**Miller:**

That's the way we did these. I'm not saying that was the best way to, but that's the way we did it.

**Questioner:**

All right, I have a question, and it relates to Jerry Leszkiewicz's talk on water balance today and the fact that water can be a limiting factor, I think, in many circumstances. And my question is, does anyone have information on gas generation beneath geomembrane covers and how that is comparing with gas generation in conventionally clay-covered landfills?

**B. Koerner:**

I recently was asked to walk over a landfill cover and tell the operator where the clay cap ended and the geomembrane began, to which I said, "How can I tell that? It's buried under 3 or 4 feet of soil." And he said, "Let's walk." Sure enough, you could tell from the odor where the geomembrane began. And that same operation decreased its well spacing from 100-foot centers with a clay cap to 300-foot centers with a geomembrane cap with the same capturing of gases.

**Questioner:**

So gas capture was similar, in that case?

**B. Koerner:**

Yeah. Also, one can show slides of geomembranes blowing up out of the cover by the methane, which you would never see for a clay cap, obviously. So I think the anecdotal information—

**Questioner:**

Right, you're probably capturing more of the gas. My question related more to the water-exclusion function of the geomembrane cap, and the one landfill that I'm aware of that I actually had a paper given in 1993 at the [Solid Waste Association of North America] SWANA Landfill Gas Conference—showed a rapidly declining gas generation. And I called them up just about a month ago and found that by now, 5 years after installation, the generation had fallen 60 percent, which seems to me to support the water-limiting conclusions that have been put forth.

**B. Koerner:**

I'm aware of the paper and the data that was collected. That's one of the bits of information that I've had...you know, I think we're going to see a lot more of that kind of information coming as people start to really compare what gas recovery they're obtaining versus what they were expecting to obtain.

**Lomer:**

Good evening. My name is Lloyd Lomer. I'm with Aurora International in Deerfield Beach, Florida. I grow bacteria, that's the main function of our company. This has been a great panel—you've solved all of the problems for the Ohio State regulators in less than 5 minutes. I guess maybe you can answer my question. (Laughter.) Seriously, sitting from this side of the table I would personally, and for some of my cohorts here, like to thank the panel and

the organizers. It's been great. The papers have been to the point, and we appreciate it. Thank you. We have some clients that have untreated leachate, a lot of it. It's just going into the bay now, 12,000 [biochemical oxygen demand] BOD. They're very reluctant to recycle this leachate back into the landfill because of the conditions of the leachate that they perceive as being no good. They would like to see some pretreatment of the leachate before it goes back into a recycle. They don't know what kind of pretreatment is going to be satisfactory, but I need some comments as to all the advantages for recycling. Does it make any sense to pretreat it to get the level down to, maybe, BODs in the 500 range rather than 12,000, or...? Any comments on that, please.

**Campbell:**

I'll make a very brief comment. I know two sites—one in Rio de Janeiro—where they have very large quantities of leachate. Basically, they're not managing a landfill in the first place. And they have got such acidic leachate they can't get a methanogenic process going. I would have said, for this all you need is very simple aeration—that they aerate this to get rid of the high levels of BOD and get it back, but they've got to get some proper capping on these sites. Some of these sites, they've tried to put gas-recovery wells in, as well, I guess for commercial purposes, and they're not working. The same applies in Chile and Argentina, okay, but there's quite a number there, and my understanding—I haven't been there, but I've seen a lot of reports, I've seen photographs, I've discussed it with the people who live in those areas and there are bad management problems that have to be resolved before they're going to solve the leachate problem. Like capping, for example. I don't think I've answered your question. Others may be able to.

**Pohland:**

Well, I think what you describe is a bioreactor that got out of control. And if the whole system becomes acid—

**Lomer:**

It has a neutral pH.

**Pohland:**

Has a neutral pH? Interesting. Normally, a functioning anaerobic system prefers a higher concentration in the substrate. So it's strange that they would have a lack of conversion, then, under a neutral-pH condition unless they have other inhibitors present.

**Campbell:**

I think part of the problem there is they've actually got a BOD that's about 50,000, and they've got enormous water infiltration that's essentially just diluting that BOD and keeping the pH more neutral. But my understanding was, they had tremendous surface- and, on the one case, groundwater-infiltration problems, and they're just flushing this thing through with an acid system, almost, and they're never, never going to have a methanogenic [system].

**Lu:**

I'm Dapei Lu from Canada, Solmers. I just have one or two more questions. For the vertical- and the horizontal-well recirculation, if it's possible clogging after long operation? Because for the study of less than 10 years' leachate recirculation, after 15 or 30 years clogging is possible. And the final question, comment to the same gentleman—we have a landfill in China, also very high organic concentration, and initial COD is 35 grams. And odor content is very high. I wonder, at the beginning, is it possible to use leachate recirculation to treat this kind of waste, or if it's not possible at the beginning, what kind of temporary treatment we can use?

**R. Koerner:**

Let me try a little part of your comments. The clogging issue is of concern. George [Koerner] made his presentation to you, and I think when it comes to perforated pipe for injection or withdrawal, the key wants to be a large opening size, and if you're using a geotextile, keep it away from the actual pipe. If you're using it, keep it around the gravel pack around the pipe. One of his sites where he found problems was a withdrawal well for gas being adjacent to an injection well, and the system short-circuited, and as the leachate was being injected for leachate recycle, it just came right over to the withdrawal well and clogged the withdrawal well. So I think the idea there is, the design formula George [Koerner] gave you, I think, is a reasonable one, and keep the filter as far away from the actual perforations in the pipe as you possibly can.

**Campbell:**

On the leachate issue, I presume we're talking in South China—the point I'm making is—because you said "organic content" and it was a comment I made earlier, what is the organic content? My suspicion is it's very high in vegetable matter and that is so readily degradable, and that's what's continually giving you these very strong acids. And there isn't anything there to allow the thing to go methanogenic properly. And again, I think it's related to keeping the water out so you've got control of it and allowing the methanogenic process to actually get established. And that would be the best treatment you can get. For your landfill is the treatment plant, should be, for things like BOD. That's my own view. Others may have a different view.

**Panelist:**

That's what I found working in Argentina, Brazil, over in Turkey, whether the waste consisted primarily of wet vegetable matter and food waste, 50, 60 percent or more of that type of material, moist contents of the waste from 50 to 65 percent. The problem is that defined field capacity, for all intents and purposes, is about equal to the initial moisture content. The refuse does not have the capability to absorb any more moisture than it's getting when waste is first brought in. And if some of that waste is beginning to decompose aerobically, it's going to liberate water, add more water to the system right away. So the problem really is water management, trying to limit the amount of additional infiltration that gets into that system so you can begin a process and control it. Otherwise, it just goes out of control. You just start getting more and more and more liquid that you try to manage and you can't deal with.

**Campbell:**

As we just heard, the Hong Kong landfills have no problem in getting very high gas generation, and the BOD levels are almost insignificant in most of the sites that I'm aware of.

**Carson:**

Let's have one last question.

**Guilfoy:**

Thank you. Mike Guilfoy again. I'd like to very quickly direct my question to Stephen Harper. The comment that you made to me is a very, very interesting one, and I think a very important point and one that I would really want to understand. I had made the comment that the recirculation permits that were written in my state were written such that if there were 12 inches of head or more on the liner, then they could not recirculate.

**Harper:**

I never thought of it that way.

**Guilfoy:**

Yeah. At the time, I think that was just kind of thought of as a given. Could you possibly elaborate on that? Is that an acceptable thing to do?



**Harper:**

I don't really know. I haven't read your state regulations. I read the 12-inch requirement in [RCRA] Subtitle D, and it seemed to me that you could get a permit to recirculate as long as you met that condition.

**Guilfoy:**

Right.

**Harper:**

And I never read it as you did, as meaning that, if we ever exceed 12 inches, then we've got to stop recirculating. But if I had read it that way before I started, then I would have said, "Okay, we can never get to 12 inches, so at 11 inches the water goes out the door." That's kind of what I was thinking. It had never occurred to me to think of it the way you're thinking of it.

**Guilfoy:**

I guess it's just looking at it from a water-balance point of you. And I may be totally off-base, but it would seem if you already had 12 inches or more on the liner and then you're adding more leachate up on top of the landfill, it seems like you would never get that head off the liner. Does anybody have experience with that?

**Harper:**

Well, that water has to percolate through a low-permeability layer. Hopefully, your drainage layer at your leachate-collection system is ten-to-one ( $1 \times 10^1$  cm/sec),  $1 \times 10^{-1}$  cm/sec, or  $1 \times 10^{-2}$  cm/sec permeability. Above that is your refuse, which is going to range from  $1 \times 10^{-5}$  to  $1 \times 10^{-3}$ . And so when you take that water out of a low-permeability area and put it back up, it's going to take some time. And in a landfill that's 50 feet or more deep, we might be talking about 6 months to a year for that water to actually percolate back down. If you haven't been recirculating for a while, then there's going to be a so-called "dry zone" there, an unsaturated zone, within the waste mass itself. And so that's a storage opportunity, as I see it. Just hadn't thought about it the way that you were thinking about it, and it struck me as if it might actually be the way the reg was intended. It might also be that you're supposed to record that, and then you get fined for every time that you exceed the 12 inches. I don't know the way it works in your state.

**Panelist:**

Let me just try to add to the discussion a little bit here. First of all, if the landfill hasn't reached field capacity and you start recirculating leachate, theoretically that waste still has the capacity to absorb additional moisture. So in addition to the time required for it to trickle through, some of it's going to get retained. And then, if my concept is right and we're in anaerobic biodegradation process, there is a consumptive water loss going on all the time as well, so that there is a need to replenish liquid through that recirculation process, i.e., you're not just taking the liquid and circulating it through the landfill without any changes in the balance. That's actually something that's occurring as it's being passed back through the landfill again on its way to the liner and leachate collection system. And the water's being removed.

**Carson:**

I think we'd better conclude our session. First, let me thank you for attending, but let's stop and reflect on this session. We've had our entire panel here for 2 hours, and they have allowed us to fire questions at them. I think we owe them a big debt of appreciation. (Applause.) Thank you very much, panel. It's much appreciated.

## Appendix A

### Speakers



# Seminar on Landfill Bioreactor Design and Operation

Wilmington Hilton  
Wilmington, Delaware  
March 23-24, 1995

## Speakers

### **Don Augenstein**

Institute for Environmental  
Management, Inc.  
4277 Pomona Avenue  
Palo Alto, CA 94306

### **David Campbell**

Waste Management  
Researcher/Consultant  
National Environmental Technology  
Centre  
AEA Technology  
Building Number E6 - Culham  
Abingdon, Oxfordshire OX14 3DB  
United Kingdom

### **David Carson**

Environmental Engineer  
Risk Reduction Engineering Laboratory  
Office of Research and Development  
U.S. Environmental Protection Agency  
26 West Martin Luther King Drive (ML-  
CHL)  
Cincinnati, OH 45268-3001

### **Stephen Harper**

Manager  
Parsons Engineering Science, Inc.  
57 Executive Park South, NE  
Suite 590  
Atlanta, GA 30329-2265

### **Jeffrey Harris**

Browning-Ferris Industries, Inc.  
P.O. Box 3151  
Houston, TX 77253

### **George Koerner**

Research Assistant/Professor  
Geosynthetic Research Institute  
Drexel University  
33rd and Lancaster Walk  
Rush Building - West Wing  
Philadelphia, PA 19104

### **Jerome Leszkiewicz**

Solid Waste Management Consultant  
Leszkiewicz Consulting International,  
Inc.  
813 Woodley Drive  
Rockville, MD 20850

### **Jan-Erik Meijer**

Development Manager  
Solid Waste Company of  
Northwest Scania, NSR  
S-251 89 Helsingborg  
Sweden

### **W. Lamar Miller**

Professor  
Environmental Engineering Sciences  
College of Engineering  
University of Florida  
320 Black Hall  
Gainesville, FL 32611-6450

### **John Pacey**

EMCON/FHC, Inc.  
P.O. Box 1804  
Pebble Beach, CA 93953

### **Robert Phaneuf**

Supervisor, Eastern  
Permitting Section  
Division of Solid Waste  
Bureau of Municipal Waste Permitting  
New York State Department of  
Environmental Conservation  
50 Wolf Road  
Albany, NY 12233-4013

### **Frederick Pohland**

Weidlein Professor of  
Environmental Engineering  
Department of Civil and  
Environmental Engineering  
University of Pittsburgh  
1141 Benedum Hall  
Pittsburgh, PA 15261



Printed on Recycled Paper